

THANOS T150 Chlorine Generator
Controls Bacteria and Algae in Swimming Pool and Spa Water

DOMESTIC

A maximum of 150,000 L water can be treated with one THANOS T150 Chlorine Generator unit

Maximum daily output of hypochlorous acid equivalent to 0.75 kg/day output of free available chlorine.

For swimming pools a range of 1-3 ppm of free available chlorine must be maintained. For spas a range of 3-5 ppm of free available chlorine must be maintained.

READ THE LABEL AND OPERATING MANUAL BEFORE USING

KEEP OUT OF REACH OF CHILDREN

REGISTRATION NO. 34925 PEST CONTROL PRODUCT ACT

WARNING: Operating the **THANOS T150** Chlorine Generator without water flow through the cell can cause a build up of flammable gas which can result in **FIRE OR EXPLOSION**.

NOTICE TO USER: This control product is to be used only in accordance with the directions on this label. It is an offense under the *Pest Control Products Act* to use a control product under unsafe conditions.

Manufactured for :
RBF International Ltée
780, rue Nobel
Saint-Jérôme (Québec) J7Z 7A3
Tel. 450 438-4416

Replacement cell label

THANOS T150 Electrolysis Cell

Replacement cell for the THANOS T150 Chlorine Generator

REGISTRATION NUMBER 34925 *PEST CONTROL PRODUCTS ACT.*

This cell must only be used on this model of salt chlorinator.

Read the Label, the Installation Manual and Operation Manual for the THANOS T150 Chlorine Generator before using.

Manufactured for :
RBF International Ltée
780, rue Nobel
Saint-Jérôme (Québec) J7Z 7A3
Tel. 450 438-4416

THANOS T150 Chlorine Generator

Installation and Operation Manual

DOMESTIC

**READ THE LABEL AND OPERATING MANUAL BEFORE USING
KEEP OUT OF REACH OF CHILDREN**

REGISTRATION NO. 34925 *PEST CONTROL PRODUCT ACT*

Manufactured for :
RBF International Ltée
780, rue Nobel
Saint-Jérôme (Québec) J7Z 7A3
Tel. 450 438-4416

IMPORTANT SAFETY INSTRUCTIONS

When using electrical equipment, basic safety precautions should always be exercised, including the following:

READ AND FOLLOW ALL INSTRUCTIONS

- Disconnect all AC power during installation.
- Do not permit children to use this product.
- A green-coloured screw is located inside the wiring compartment, against the back panel. To reduce the risk of electric shock, this terminal must be connected to the grounding means provided in the electric supply service panel with a continuous copper wire equivalent in size to the circuit conductors supplying the equipment.
- One bonding lug for US models (two for Canadian models) is provided on the external surface. To reduce the risk of electric shock, connect the local common bonding grid in the area of the swimming pool, spa or hot tub to these terminals with an insulated or bare copper conductor not smaller than 8 AWG US/6 AWG Canada.
- All field-installed metal components such as rails, ladders, drains, or other similar hardware located within 3 metres (10 feet) of the pool, spa or hot tub shall be bonded to the equipment grounding bus with copper conductors not smaller than 8 AWG US/ 6 AWG Canada.

SAVE THESE INSTRUCTIONS

Table of Contents

OPERATION

General.....	5
Water chemistry.....	5
Controls.....	12
Maintenance.....	15

INSTALLATION

Mounting.....	17
Plumbing.....	17
Wiring.....	19

TROUBLESHOOTING

Troubleshooting.....	23
----------------------	----

WARRANTY

Warranty.....	26
---------------	----

OPERATION

The THANOS T150 is an automatic chlorine generation system for pool & spa sanitation. The operation requires a low concentration of salt (sodium chloride) in the pool/spa water at levels low enough that it normally cannot be tasted. THANOS T150 automatically sanitizes your pool/spa by converting the salt into free chlorine, which kills bacteria and algae in the pool/spa through a process called electrolysis.

THANOS T150 is designed to handle the purification needs of the average residential swimming pool/spa up to 150,000 litres (40,000 gallons). The actual amount of chlorination required to properly sanitize a pool/spa varies depending upon bather load, rainfall, air temperature, water temperature, pool/spa's exposure to sunlight, pool/spa's surface, and cleanliness.

Note: It is not recommended using the THANOS T150 to generate Bromine.

If your pool/spa has natural stone as coping or decking, please check with a stone installation specialist for the maintenance of the stone before installing the THANOS T150.

WATER CHEMISTRY

As with any pool/spa, it is important that you maintain proper water chemistry of the pool/spa water, including pH, alkaline content, and calcium levels. The only special requirement for THANOS T150 is to maintain proper levels of salt and stabilizer. It is important to maintain these levels in order to prevent corrosion or scaling. Test your water periodically. It is recommended that pool/spa water be professionally tested a minimum of twice per season. Your local pool/spa store can provide you with the chemicals and procedures to adjust the water chemistry. Be sure to tell the pool/spa store that you are using a salt chlorine generator.

IDEAL CHEMICAL LEVELS

Salt	3200 to 4000 ppm
Free chlorine	1-3 ppm for pool 3-5 ppm for spas

pH	7.2 to 7.6
Cyanuric Acid (Stabilizer)	50 to 100 ppm
Total Alkalinity	100-120 ppm
Calcium Hardness	200-300 ppm for pool 150-200 ppm for spas
Metals	0 ppm
Saturation Index	-.2 to .2

Saturation index

The saturation index (Si) relates to the calcium and alkalinity in the water and is an indicator of the pool/spa water "balance". Your water is properly balanced if the Si is 0 ± 0.2 . If the Si is below -0.2 , the water is corrosive and plaster pool/spa walls will be dissolved into the water. If the Si is above $+0.2$, scaling and staining will occur. Use the chart below to determine the saturation index.

$$Si = pH + Ti + Ci + Ai - 12.1$$

	Ti	Calcium Hardness	Ci	Total Alkalinity	Ai	
12	53	.3	75	1.5	75	1.9
16	60	.4	100	1.6	100	2.0
19	66	.5	125	1.7	125	2.1
24	76	.6	150	1.8	150	2.2
29	84	.7	200	1.9	200	2.3
34	94	.8	250	2.0	250	2.4
39	103	.9	300	2.1	300	2.5
			400	2.2	400	2.6
			600	2.4	600	2.8
			800	2.5	800	2.9

How to use: Measure pool/spa pH, temperature, calcium hardness, and total alkalinity. Use the chart above to determine Ti, Ci, and Ai from your measurements. Insert values of pH, Ti, Ci and Ai into the above equation. If Si equals .2 or more, scaling and staining may occur. If Si equals -.2 or less corrosion or irritation may occur.

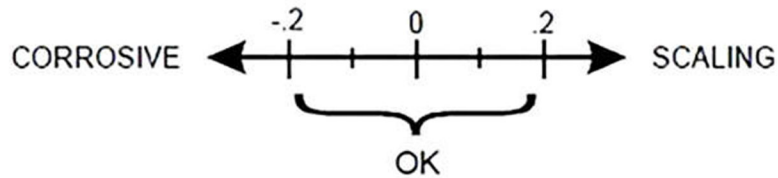

SALT LEVEL

Use the chart below to determine the amount of salt needs to be added to reach the recommended levels. Use the equations below to determine the size of your pool/spa.

	Gallons (pool/spa size feet)	Litres (pool/spa size in metres)
Rectangular	Length×Width×Average Depth×7.5	Length×Width×Average Depth×1000
Round	Diameter×Diameter×Average Depth×5.9	Diameter×Diameter×Average Depth×785
Oval	Length×Width×Average Depth×6.7	Length×Width×Average Depth×893

- The ideal salt level is between 3000-4000 ppm. (parts per million) with 3400 ppm being the optimal level. Calculate the number of gallons in the pool/spa and add salt according to the chart on page10.
- A LOW salt level will reduce the efficiency of the production and result in low chlorine production.
- Excessively HIGH salt levels will cause the THANOS T150 to shut down, making pool/spa water unsafe for bathers. LOW salt levels can cause the THANOS T150 not to operate efficiently, causing the same.

Type of Salt to Use

It is important to use only sodium chloride (NaCl) that is 99% pure. This is common food quality or water softener salt available in 18-36 kg (40-80 lb) bag at your local store. It is also acceptable to use water conditioning salt pellets; however, it will take longer for them to dissolve. Do not use rock salt, salt with more than 1% yellow prussiate of soda, salt with more than 1% of anti-caking additives, or iodized salt.

How to Add or Remove Salt

- IN GROUND POOL/SPAS: Turn the filter pump on and add the salt directly into the pool/spa at the shallow end.
- ABOVE GROUND POOL/SPAS WITH MAIN DRAINS: Add directly in front of the return jet to pool/spa. Run the filter pump for 24 hours with the suction coming from the main drain (use the pool/spa vacuum if there is no main drain) to allow the salt to evenly disperse throughout the pool/spa.

- ABOVE GROUND POOL/SPAS WITHOUT MAIN DRAINS: Add directly into the pool/spa. Brush the salt to speed up the dissolving process—to not allow the salt to sit in a pile on the bottom of the pool/spa -----ELIMINATE THE FOLLOWING--(Run the filter pump for 24 hours with the suction coming from the main drain (use the pool/spa vacuum if there is no main drain) to allow the salt to evenly disperse throughout the pool/spa).

ON ANY POOL/SPA, DO NOT ADD SALT DIRECTLY TO THE SKIMMERS OR DIRECTLY ONTO THE MAIN DRAIN. THIS WILL SHUT DOWN OR SHORTEN THE LIFE OF THE CELL DUE TO HIGH SALT CONCENTRATION AND REDUCED FLOW TO THE PUMP.

If added incorrectly, immediately turn off THANOS T150 for 24 hours with the pump and filter operating. This will help to evenly distribute the salt. The salt display may take 24 hours to respond to the change in salt concentration.

SALT DOES NOT EVAPORATE FROM POOL/SPA

The only way to lower the salt concentration is to partially drain the pool/spa and refill with fresh water.

POUNDS and (Kg) OF SALT NEEDED FOR 3400 PPM

Gallons and (Litres) of Pool/Spa water

Current salt level ppm	6,000 (22,500)	8,000 (30,000)	10,000 (37,500)	12,000 (45,000)	14,000 (52,500)	16,000 (60,000)	18,000 (67,500)
0	180 (82)	239 (109)	301 (136)	360 (163)	419 (190)	481 (218)	540 (245)
200	170 (78)	226 (103)	284 (129)	340 (154)	396 (180)	454 (206)	510 (232)
400	160 (73)	213 (97)	267 (121)	320 (145)	373 (170)	427 (194)	480 (218)
600	150 (69)	200 (91)	250 (114)	300 (136)	350 (159)	400 (182)	450 (205)
800	140 (64)	187 (85)	233 (106)	280 (127)	327 (148)	373 (170)	420 (191)
1000	130 (59)	173 (79)	217 (98)	260 (118)	303 (138)	347 (158)	390 (177)

POLYMERS:

It is advised to use polymers (commonly sold as poly algaecide) on salt water sanitizing systems. The poly algaecide is sold in 30% and 60% concentrations.

Application rate is 1 quart of Poly30 (or ½ quart of Poly 60) per 60 000 litres (15,000 gallons) of pool/spa water, per month. Apply directly in front of the return jet.

CONTROLS

MAIN SWITCH

- **AUTO:** For normal operation, the Main switch should be left in the AUTO position. In this position the THANOS T150 will produce chlorine according to the "Desired Level %" adjustment setting for the entire filtering / pumping cycle.
- **SUPER CHLORINATE:** When you have an abnormally high bather load, heavy rainfall, cloudy water conditions, or any other condition which requires that a

large amount of purification be introduced, set the Main Switch in the SUPER CHLORINATE position. This electronically “super chlorinates” (shocks) the water for 24 hours (filter pump must be on during this time) or until the power has been turned off, whichever comes first. At the end of the super chlorination period, be sure to put the switch back into the AUTO position.

- **OFF:** The OFF position prevents the THANOS T150 from energizing the electrolytic cell. In this position there is no chlorine generation.

NOTE: In times of servicing, the OFF switch is not to be used. To service the THANOS T150, turn power off the circuit breaker.

DESIRED LEVEL ADJUSTMENT KNOB

This setting is used to control the amount of chlorine the THANOS T150 generates. Adjust this setting to increase or decrease the chlorine output level. The reading is from 5 percent output to 100% output capacity of the THANOS T150.

INDICATOR LED

- **POWER:** When illuminated, the THANOS T150 has input power.
- **GENERATING:** This LED is on steady during normal operation. When flashing, the pool/spa water is too hot or cold to operate.
- **SUPER CHLORINATE:** Illuminates during Super Chlorination. See description above.
- **REMOTE CONTROLLED:** The part is controlled by a remote control system.
- **NO FLOW:** When illuminated, the flow switch has detected no flow and THANOS T150 is NOT generating chlorine. A flashing LED indicates that the flow is restored, but there will be a 60 second delay before generation is reestablished.
- **CHECK SALT:** When flashing, the salt level is low (below 2500 ppm) and THANOS T150 is generating at low efficiency. When illuminated steady, the salt level is too low and THANOS T150 has shut down.

Note: Before adding large quantities of salt, it is advisable to have your salt level professionally checked.

- **HIGH SALT:** When illuminated, the salt level is too high and THANOS T150 has shut down. The pool/spa water must be diluted with fresh water before operation is restored.
- **INSPECT CELL:** If flashing, either the cell efficiency is reduced or it is time for regularly scheduled cell inspection. In either case, inspect the cell and clean if necessary. Pressing the "diagnostic" button next to the display for 3 seconds will stop the flashing LED. When illuminated steady, cell efficiency is greatly reduced and THANOS T150 has stopped producing chlorine. Inspect, clean or replace if necessary.

SALT DISPLAY

The Salt Display shows the current salt concentration of the pool/spa water. Readings are in ppm (parts per million). If Metric units (grams per litre) are preferred, push the "diagnostic" button next to the display once. The display will now show the pool/spa water temperature in degrees Fahrenheit. With the temperature displayed, move the main switch from AUTO to SUPER CHLORINATE to AUTO. The temperature display will instantly change to degrees Celsius. Repeat this process to switch back to USA units (Fahrenheit).

Diagnostic Displays

Sequential pushes of the small "diagnostic" button next to the LCD display will cause the Aqua Rite to display the following information:

1. Pool/spa temperature (xx degrees Fahrenheit or Celsius)
2. Cell voltage (typically 21.0 to 27.0 volts when chlorine is being generated, otherwise 16-25V)
3. Cell current (typically 2.50 to 7.80 amps when chlorine is being generated, otherwise 0 amps)
4. Desired Output % ("0P" -- "100P" depending on knob position or input from remote pool/spa automation controller)
5. Instant salinity (-xxxx ppm or -x.xx grams/litre)
6. Product name sent to the pool/spa automation control display

7. Software revision level

8. Cell type.

On the 8th push of the button the display will revert back to the default salt display. Also, if the button is not pushed for 30 seconds, the display will revert back too.

OPERATION

By familiarizing yourself with the operation of the THANOS T150 generator, you can achieve maximum performance for your pool/spa. When chemical levels are in the recommended range, there are FOUR factors that you can control which directly contribute to the amount of chlorine the THANOS T150 will generate:

- Filter time each day (hours)
- The amount of salt in the pool/spa
- The "Desired Level %" setting
- Stabilizer level in the water.

To find the optimum "Desired Level %" setting, start at a fairly high setting and work downward. It will take a few days of adjustments to find the ideal setting for your pool/spa. Once determined, it should only take minor adjustments. The THANOS T150 control will not produce chlorine at temperatures below 10°C (50°F). If your pool/spa water is colder than 10°C (50°F), you must chlorinate manually.

Maintaining the System

To maintain maximum performance, it is recommended that you remove and visually inspect the cell every 3 months. The THANOS T150 will remind you to do this by flashing the "Inspect Cell" LED after approximately 500 hours of operation. After you inspect the cell (and clean, if necessary) press the small "diagnostic" button next to the display for 3 seconds to stop the flashing "Inspect Cell" LED and start the timer for the next 500 hour inspection period.

The THANOS T150 electrolytic cell has a self-cleaning feature incorporated into the electronic control's logic. In most cases this self-cleaning action will keep the cell working at optimum efficiency. In areas where water is hard (high calcium and/or mineral content)

and in pool/spas where the water chemistry has gotten "out of balance", the cell may require periodic cleaning. The "Inspect Cell" LED remains on after a thorough cleaning, the cell may be worn and may require replacement.

Servicing and Cleaning the cell

- Turn off power to the THANOS T150 before removing the **CELL**.
- Once removed, look inside the cell and inspect for scale formation (light coloured crusty or flaky deposits) on the plates and for any debris that has passed through the filter and gotten caught on the plates.
- If no deposits are visible, reinstall. If deposits are seen, use a high-pressure garden hose and try to flush the scale off. If this is not successful, use a plastic or wood tool to scrape deposits off of the plates. **DO NOT USE A METAL SCRAPER AS THIS WILL SCRATCH THE FINISH AND DAMAGE THE PLATES.** Note that a buildup on the cell indicates that there is an unusually high calcium level in the pool/spa (old pool/spa water is usually the cause). If this is not corrected, you will need to clean the cell more frequently. The simplest way to avoid this is to bring the pool/spa chemistry to recommended levels, as specified.

Mild Acid Washing:

Use only in severe cases where flushing and scraping will not remove the majority of deposits. To acid wash:

- Turn off power to THANOS T150.
- Remove cell from piping.
- In a clean plastic container, carefully mix a 4:1 solution of water to muriatic acid (4 litres of water to one litre of muriatic acid) (one gallon of water to one quart of muriatic acid).

ALWAYS POUR ACID INTO WATER-NEVER POUR WATER INTO ACID.

**BE SURE TO WEAR PROTECTIVE GLASSES, CLOTHING AND CHEMICAL
RESISTANT GLOVES**

- The level of the solution in the container should just reach the top of the cell so that the wire harness compartment is NOT submerged. It may be helpful to coil the wiring before immersing the cell.
- The cell should soak for FIVE minutes, then rinse with a high-pressure garden hose.
- If any deposits are still visible, repeat soaking and rinsing.
- Replace cell and inspect again periodically.

Winterizing

The THANOS T150 electrolytic cell and flow detection switch will be damaged by freezing water, similar to other pool/spa components that require proper winterization. In areas of the country that experience severe or extended periods of freezing temperatures, be sure to drain all water from the pump, filter, and supply and return lines before any freezing conditions occur. The electronic control is capable of withstanding any winter weather and should not be removed.

Spring Start-up

DO NOT turn THANOS T150 on, until the pool/spa water chemistry has been balanced to proper levels.

INSTALLATION

Installation must be performed in accordance with Local NEC codes.

Preparing Pool/spa Water:

The pool/spa's chemistry must be balanced BEFORE activating the THANOS T150.

It is recommended that you consult a pool/spa professional for the initial balancing each season.

NOTE: At the beginning of each season, add metal remover and polymer based (non copper) algaecide to the pool/spa, per manufacturer's instructions. This ensures a quick, trouble free transfer to the THANOS T150 system.

Mounting the THANOS T150 Control

The THANOS T150 is contained in a rain tight enclosure that is suitable for outdoor mounting. The control must be mounted a minimum of 2 metres (5 ft.) horizontal distance (or more if local codes require) from the pool/spa.

The control is designed to mount vertically on a flat surface with the knockouts facing downward. Because the enclosure also acts as a heat sink (disperses heat from inside the box), it is important not to block the four sides of the control.

Do not mount the THANOS T150 in a panel or tightly enclosed space.

Plumbing

Ensure that the THANOS T150 installation does not constitute a cross connection with the local potable water supply. Consult local plumbing codes.

The cell and flow switch are plumbed in the return line to the pool/spa. Install after (downstream) all the pool/spa equipment (filter, heater, solar, etc.). The kit included in the THANOS T150 provides the necessary plumbing components for:

- 2" (51mm) rigid PVC piping installation for in ground pool/spas
- 1 1/2-1 1/4" (38-32mm) flexible hose connections for above ground

pool/spas. For proper plumbing, refer to the overview diagram below

Flow switch:

IMPORTANT: To insure proper operation, verify that the arrow on the flow switch (located on the side) points in the same direction of water flow.

Electrolytic Cell:

Install using the unions provided. Tighten by HAND for a watertight seal. For pool/spa combination systems with spillover, use configurations #2 or #3 above to allow chlorination for both the pool/spa during spillover but preventing over chlorination when operating the spa only.

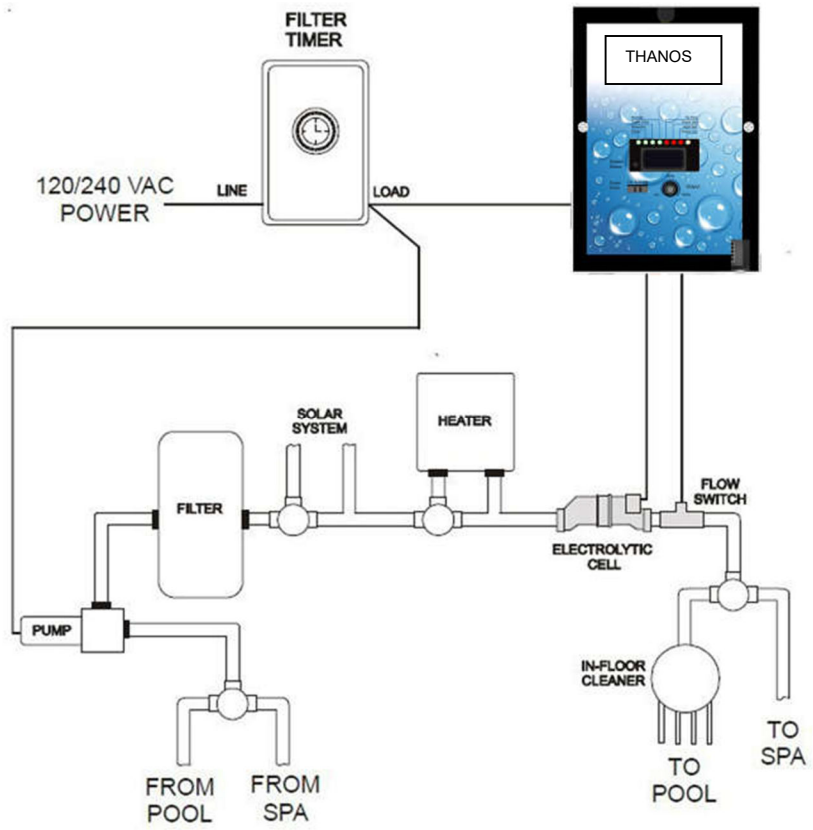

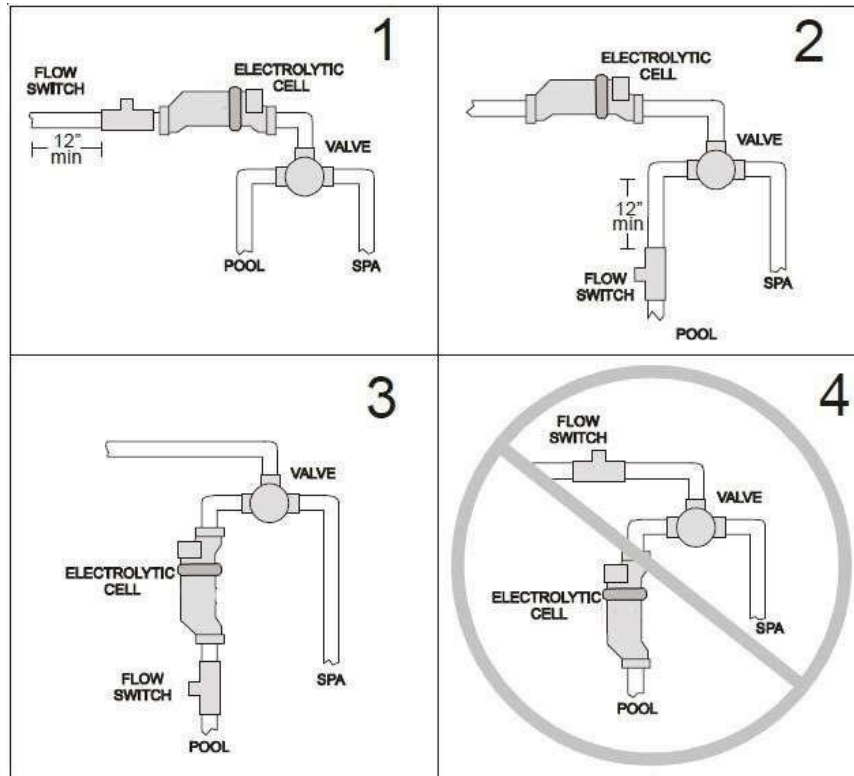

Wiring

Power must be turned off at the circuit breaker before performing any wiring. Be sure to follow Local and NEC electrical codes. To provide safe operation, THANOS T150 must be properly grounded and bonded.

Input Power for stand-alone operation:

Wire the THANOS T150 to the LOAD SIDE of the filter pump timer. It is very important that the THANOS T150 is powered only when the pump is running.

Refer to the wiring label on THANOS T150 as well as the diagram below to determine correct wiring connections. The THANOS T150 is shipped from the factory with the configuration jumpers in a separate bag. Until the jumpers are installed for the desired voltage, the unit should NOT be turned on.

- For Canadian models, the THANOS T150 shall be connected to a circuit protected by a class A ground fault interrupter. Be sure to connect the GROUND wire to the green ground screw terminal located on the INSIDE WALL of the enclosure.

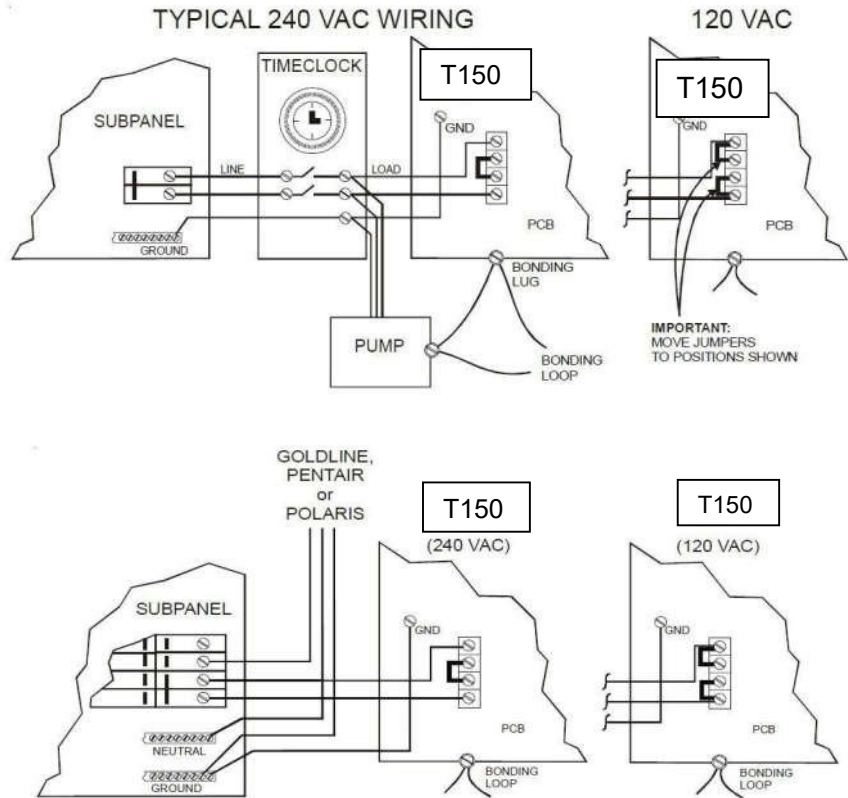

Note: Wire the pump directly to the time clock—do not use the THANOS T150 as a junction box.

Bonding:

A lug used for bonding is attached to the bottom of the THANOS T150 enclosure (see diagram below). The THANOS T150 must be bonded with an 8 AWG copper wire (6 AWG Canada) to the pool/spa bonding system.

Electrolytic Cell and Flow Switch:

The electrolytic cell and flow switch cables are terminated with connectors that plug into the THANOS T150 for easy attachment and removal. The door of the THANOS T150 must be open to access the cell cable connector. The flow switch plugs into a connector (similar to a telephone jack) located outside, on the bottom of the enclosure. Refer to the diagram below for the location of these connections.

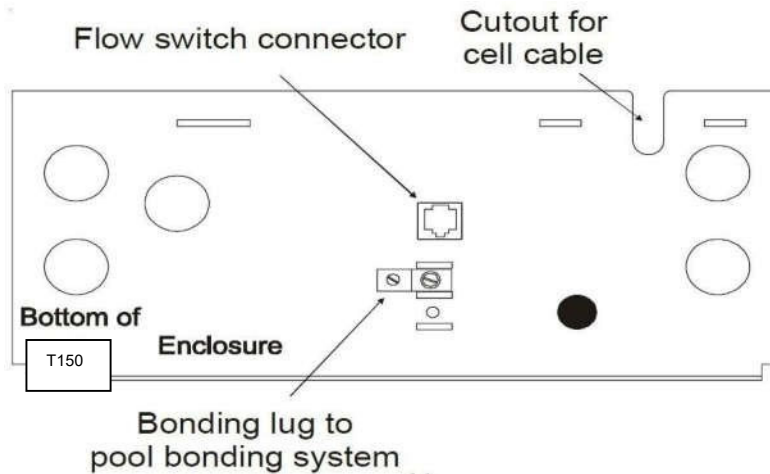

Input power for use with Goldline, Pentair and Polaris controls:

Wire the THANOS T150 DIRECTLY TO 120/240vac POWER (not through timer or relay). Optional Goldline, Pentair and Polaris controls:

The Goldline, Pentair and Polaris controls use a 4 wire connection to communicate to the THANOS T150 and can be wire up to 500' apart. Any outdoor rated 4 conductor cable can be used. Refer to each manufacturer's instructions and the wiring diagrams below for proper wiring connection to the THANOS T150.

NOTE: There must be only 1 "primary" unit. All other THANOS T150 units must be configured as "secondary".

Goldline-Attach wires to proper screw terminals as show below.

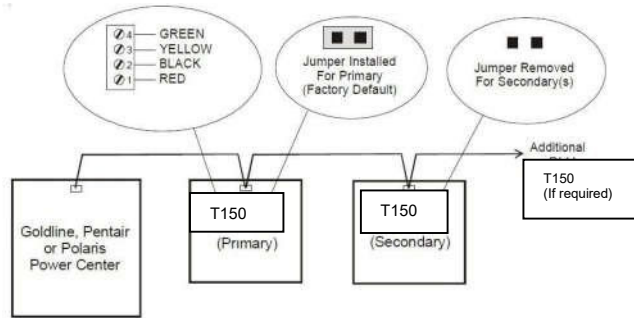

Goldline - Attach wires to proper screw terminals as shown below.

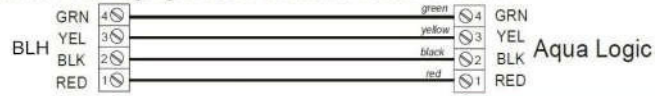

Pentair - Attach wires to opposite numbered screw terminals as shown below. Note that the colours marked on the Pentair PCB do not match the THANOS T150.

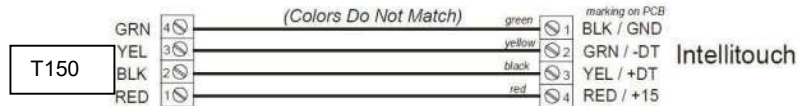

Polaris - Attach wires to proper screw terminals as shown below. Note that screw terminal "1" is marked on the Polaris PCB.

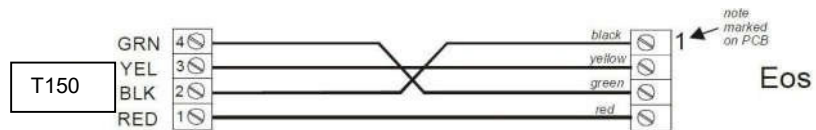

TROUBLESHOOTING

Diagnostic Displays

Sequential pushes of the small “diagnostic” button next to the LCD display will cause the THANOS T150 to display the following information:

1. Pool/spa temperature (xx degrees Fahrenheit or Celsius)
2. Cell voltage (typically 21.0 to 27.0 volts when chlorine is being generated, otherwise 16-25V)
3. Cell current (typically 2.50 to 7.80 amps when chlorine is being generated, otherwise 0 amps)
4. Desired Output% (“0P”—“100P” depending on knob position)
5. Instant salinity (-xxxx ppm or-x.xx grams/litre)
6. Product name sent to the display
7. Software revision level
8. Cell type

On the 8th push of the button the display will revert back to the default salt display. Also if the button is not pushed for 30 seconds, the display will revert back default salt.

Common Problems and Solutions

1. “Power” LED not on

Check to make sure 120 / 240 VAC input power is connected to the control. Be sure the jumpers are set properly. Verify input voltage with a voltmeter. If there is input power, the fuse may have blown. The board is protected by a 20 amp mini ATO fuse located on the circuit board above the cell connector.

2. “Generating” LED flashing

The temperature of the pool/spa water is too high or low to operate. You can override this by switching the main switch to SUPER CHLORINATE. The THANOS T150 will run at maximum output for the remainder of the current pump cycle or 24 hours, whichever comes first.

3. “No Flow” LED illuminated or flashing

The THANOS T150 has sensed a no flow condition and has stopped generating chlorine. Check that the flow switch is plugged into the connector on the bottom of the control unit and that the wire is not cut or damaged. Make sure you have at least 30 cm (12”) of straight

pipe before the flow switch. If there is adequate flow and the LED is still on, check that the arrows on the flow switch (on top of hex) are pointing in the direction of flow. If the light is flashing, the flow is established and the THANOS T150 will turn on within 1 minute.

4. "Check Salt" LED illuminated or flashing

Check salt level in pool/spa. If salt level is low, add salt according to chart on page 4. Before adding large quantities of salt, it is advisable to have your salt level professionally checked.

5. "High Salt" LED illuminated

Check salt level in pool/spa. If salt level is too high, lower salt level by draining some of the pool/spa water out of the pool/spa and replace with fresh water. Continue until the salt concentration is at recommended levels.

6. "Inspect Cell" LED flashing

Inspect and clean cell according to directions. When done, press the "diagnostic" button for 3 seconds to stop the "Inspect Cell" LED flashing.

7. "Inspect Cell" LED illuminated

Remove and inspect the cell for scale. If the cell is scaled, follow the directions on page 8 for cell cleaning. If the pool/spa has the proper amount of salt and the "Inspect Cell" LED is still illuminated, the cell may be depleted and needs to be replaced.

8. Possible causes of low chlorine or no chlorine

- THANOS T150 switch in OFF position.
- Desired Level% adjustment setting is too low.
- Low stabilizer (Cyanuric Acid). Chlorine is being produced but the pool/spa water is unable to hold on to the chlorine, due to low stabilizer.
- Filter pump switched off or filter pump time too short (8 hours for average size pool/spas, more for large pool/spas).
- Salt level too low (below 2500 ppm, Low Salt LED on).
- Salt level too high (high Salt LED on).
- Low pH. Low pH oxidizes chlorine quickly, making it difficult to maintain desired chlorine levels. Adjust pH levels to re-balance water.
- Warm pool/spa water increases chlorine demand—increase Desired Level% or filter run time.
- Cold water (below 10C (50F)) can cause THANOS T150 to stop generating

FIVE / SEVEN YEAR LIMITED WARRANTY

THANOS T150 is warranted to be free from defects in materials and workmanship, under normal use and non-commercial application, for a period of Five (5) years or Seven (7) years, per the schedule below. To obtain service, contact RBF International at www.rbfinternational.com. Proof of purchase is required. This limited warranty is extended exclusively to the original purchaser of the *THANOS T150* system and is non-transferable. *THANOS T150* is intended for residential pool/spa use and any commercial application voids all warranties.

Five (5) year limited warranty schedule for power cell and generating cell.

During year one: 100%
During year two: 100%
During year three: 60% prorated
During year four: 70% prorated
During year five: 80% prorated
All remaining components: two year, full

Seven (7) year limited warranty schedule for power cell and generating cell.

During year one: 100%
During year two: 100%
During year three: 100%
During year four: 60% prorated
During year five: 75% prorated
During year six: 80% prorated
During year seven: 80% prorated
All remaining components: three year, full

Exclusions:

- Problems arising from failure to maintain proper water chemistry levels, per manufacturer's recommendations, as outlined in the Owner's Manual.
- Problems arising from failure to use *THANOS T150* in accordance to manufacturer's recommendations, as outlined in the Owner's Manual.
- Problems resulting from tampering, accident, electrical surges, abuse, neglect, unauthorized or unqualified repairs, product alteration, fire, flood, freeze damage, Acts of Nature or Acts of God.

- Damage or degrading of concrete, natural stone, wood or synthetic surfaces adjacent to the swimming pool or spa.
- Problems or damages incurred due to improper installation and/or improper electrical supply.

Please visit www.rbfinternational.com for more information, useful tips, and troubleshooting assistance, or call us at 450 438-4416.