

REPLACEMENT CELL TMI SALT PURE SALINE CHLORINATION SYSTEM, Model zX-5  
TMI SALT PURE zX-5 REPLACEMENT CELL

Replacement electrode for the generating device TMI Salt Pure Saline Chlorination System, Model zX-5  
REGISTRATION NUMBER 32769, PEST CONTROL PRODUCT ACT. This cell must only be used on this model device.

Read the Label, the Installation Manual of the generation device TMI Salt Pure Saline Chlorination System,  
Model zX-5 before using.

TMI SALT PURE CORPORATION, 1605 ALASKA AVENUE EAST  
PORT ORCHARD, WASHINGTON, U.S.A., 98366. **1-800-818-8266**

TMI Salt Pure Saline Chlorination System, Model zX-5  
CHLORINE GENERATOR

CONTROLS BACTERIA AND ALGAE  
In  
Swimming Pool (and Spa) Waters

COMMERCIAL

A maximum of 283,900 L of water can be treated with TMI Salt Pure Chlorination System, Model zX-5

Maximum output of hypochlorous acid equivalent to 2.268 kg of free available chlorine per day.

For swimming pools, a range of 1.0-3.0 ppm of free available chlorine must be maintained.

For spas, a range of 3.0-5.0 ppm of free available chlorine must be maintained.

KEEP OUT OF REACH OF CHILDREN

READ THE LABEL AND OPERATING MANUAL BEFORE USING

REGISTRATION NUMBER 32769 PEST CONTROL PRODUCT ACT

WARNING: Operating the TMI Salt Pure Corporation Chlorination System, Model zX-5, without water flow through the cell can cause a buildup of flammable gases which can result in FIRE OR EXPLOSION.

DO NOT USE THIS DEVICE WITH BROMIDE PRODUCTS

NOTE TO USER: The pest control product is to be used only in accordance with the directions on the label. It is an offence under the Pest Control Products Act, to use this product in a way that is inconsistent with the directions on the label.

TMI SALT PURE CORPORATION, 1605 ALASKA AVENUE EAST  
PORT ORCHARD, WASHINGTON, U.S.A., 98366. **1-800-818-8266**



# TMI Salt Pure<sup>®</sup> zX Series

## SALINE CHLORINATOR

### Installation, Operation, and Maintenance Manual



# TABLE OF CONTENTS

<b>WELCOME</b>	
<b>Overview of TMI Salt Pure® System ZX-5</b>	<b>4</b>
<b>1.0 DESCRIPTION</b>	<b>5</b>
<b>1.1 General Information</b>	<b>5</b>
<b>1.2 Principals of Operation</b>	<b>6</b>
<b>1.3 General Specifications and Sizing Guidelines</b>	<b>6</b>
<b>2.0 INSTALLATION</b>	<b>7</b>
<b>2.1 Unpacking</b>	<b>7</b>
<b>2.2 Storage</b>	<b>7</b>
<b>2.3 Safety Considerations</b>	<b>8</b>
<b>2.4 Plan Ahead</b>	<b>9</b>
<b>2.5 Installation Diagram with Single Cell Shown</b>	<b>10</b>
<b>2.6 Multiple zX Cell Mounting Diagram</b>	<b>11</b>
<b>2.7 Power Supply Installation</b>	<b>11</b>
<b>2.8 Acid Feed Installation</b>	<b>12</b>
<b>2.9 Electrolytic Cell Installation</b>	<b>12</b>
<b>2.10 Flow Switch Installation</b>	<b>12</b>
<b>2.11 Installing the Mechanical Flow Switch</b>	<b>12</b>
<b>2.12 Installing the SaltSecure®</b>	<b>12</b>
<b>2.13 Electrical Supply – Connecting to AC Power</b>	<b>13</b>
<b>2.14 Connecting Cell to Power Supply</b>	<b>13</b>
<b>2.15 System Wiring</b>	<b>14</b>
<b>3.0 OPERATION</b>	<b>15</b>
<b>3.1 Preparing the Water</b>	<b>15</b>
<b>3.2 Starting the System</b>	<b>17</b>
<b>3.3 System Operation</b>	<b>18</b>
<b>3.4 Display Information</b>	<b>18</b>
<b>4.0 MAINTENANCE</b>	<b>19</b>
<b>5.0 TECHNICAL GUIDE</b>	<b>21</b>
<b>6.0 WARRANTY INFORMATION</b>	<b>31</b>
<b>PARTS LIST</b>	<b>32</b>
<b>SALT PURE® SYSTEM INSTALLATION &amp; COMMISSIONING FORM</b>	<b>36</b>
<b>CHECKLIST</b>	<b>37</b>

Note: This manual is subject to change at any time based on system improvements, design changes, authorized modifications or new information. Please consult TMI for the latest revision.

TMI Salt Pure Corporation DBA TMI Sustainable Aquatics  
PO BOX 433  
Manchester, WA 98353  
[techsupport@tmiaquatics.co](mailto:techsupport@tmiaquatics.co)  
[m](#)

# **WELCOME TO TMI SALT PURE® WATER**

We at TMI SALT PURE® are dedicated to providing you with the most luxurious, healthy, 'natural' pool water you have ever experienced, as well as the most reliable product and the best after-sales service you could hope for. Reading this Guide will help ensure that your Salt Pure® system functions correctly and will elaborate on certain maintenance procedures which, if left undone, may void warranties.

## **Support**

Every Salt Pure® system comes with technical support for the lifetime of the equipment.

We have also included a guided Trouble-Shooting section into this Manual on page 21 for field reference when needed.

## **Chemistry Control**

**!!STOP!!** Not all chemistry controllers are compatible with the zX system, before connecting to a chemistry controller, contact your Technical support representative to ensure compatibility.

## **Testing Supplies**

In order to properly run your new zX series system, you will need reliable, commercial test kits. This should include:

*pH, Chlorine, Salt, Calcium, Alkalinity, Cyanuric Acid and Phosphates.*

TMI provides a full range of kits for every need. If you need a new kit, or simply replacement items, contact TMI first to ensure you have the right testing supplies on hand.

## **Preventative Maintenance**

Did you know that not all chemicals are fully compatible with chlorine generators? TMI offers a complete range of Specialty chemicals that are compatible with chlorine generators that improve water quality, system performance and help reduce downtime while keeping your water sparkling clear at all times.

Contact your TMI Technical support rep. for assistance in selecting the PMP that is right for you.

## Overview of the TMI SALT PURE® System

A Salt Pure® system is NOT chlorine free, it simply produces pure sodium hypochlorite which is free from all the additives and preservatives in both bottled liquid and tablet/granular chlorine that made it shelf stable and also cause many of the common reactions associated with chlorine (Bleached swim suits, hair color changes and skin irritation).

Chlorine generation is a natural process and even takes place to a small degree in ocean water!

So how does it work?

Here is the process:

When salt (99% NaCl – additive free) is dissolved in pool water and then subjected to electrolysis inside the zX cell, Sodium Hypochlorite “Liquid Chlorine” in the form of HOCl\* is produced.

The HOCl sanitizes the water by killing bacteria, virus, algae and other harmful or nuisance organisms.

The chlorine generation process is cyclical, the salt is not consumed, the chlorine returns to salt after sanitizing the water, to be turned back into chlorine again when the system is energized.

This process will repeat as many times as needed until the chlorine demand is met and the water is sanitized.

Each zX system should be designed to suit your particular pool or spa to ensure best results.



\*HOCl – Hypochlorous Acid is the same effective sanitizer contained in ‘liquid chlorine’ – when produced inline this is 100% Free Available Chlorine without the additives, fillers or stabilizers found in pre-packaged or bottled chlorine.

# SECTION 1 DESCRIPTION

## 1.1 GENERAL INFORMATION

The TMI Salt Pure® zX-5 is designed for commercial swimming pool applications and is capable of producing up to 2.25 kg (5 pounds) of equivalent chlorine per day. The system manufactures sodium hypochlorite continuously from a salt concentration of 3500 to 4500 ppm added to the pool. The TMI Salt Pure® zX-5 is designed for commercial service and will be best operated by a TMI chemistry controller. All zX models have digital displays that show system status.

## 1.2 PRINCIPALS OF OPERATION

### Electrolytic Cell Assembly

The electrolytic cell assembly consists of a cell housing and electrolytic cell.

- The housing is made of clear PVC for visual inspection, inlet and effluent ports and a fixed flange for the electrolytic cell to mount to.
- The electrolytic cell is made up of multiple titanium plates coated with a protective mixture of titanium & ruthenium. This coating allows the system to produce chlorine while resisting the oxidation effect of the production process. This coating will wear over time, and once depleted, the cell must be replaced.

### Power Pack - Supply and Control Box

The power pack provides the current to the electrolytic cells to produce the rated amount of sodium hypochlorite. The power pack used switch-mode technology in its self-selecting power supply. This is currently the most electrically efficient method of producing current for an electrolytic cell as the system can operate from 110vAC up to 240vAC without the need for special wiring changes, while supplying the same output power to the cell. The power pack houses all the safety features to prevent system operation in the event of a malfunction. As well as the logic control interface and LED status screen.

## SIZING GUIDELINES

All systems must be sized by TMI for warranty to be valid. In some areas additional requirements must be met to comply with local codes. Please contact your local TMI representative for assistance.

### 1.3 GENERAL SPECIFICATIONS

#### SODIUM HYPOCHLORITE PRODUCTION:

Model Designation	Sodium Hypochlorite Production (kg/day)	Rated Power in DC Amps	Rated Pressure	Minimum / Max Water Flow Rate (gpm)	Weight Power Supply/Cell	Inlet/ Outlet Diameter (Inches)
TMI Salt Pure® zX-5	2.25 kg/day (5lbs/day)	36	3.5 kg/cm (50 psi)	95 / 660 lpm (25/175 gpm)	7.7 / 11.8 kg (17 / 26 lbs)	7.6 cm (3 inch)

#### ELECTRICAL REQUIREMENTS:

Input voltages are self-selecting.

Model Designation	AC Input Voltage	Phases	Frequency	Amps	GFCI Breaker
TMI Salt Pure® zX-5	120 VAC	1	50/60Hz	8	15
	208 VAC	1	50/60Hz	4.6	15
	240 VAC	1	50/60Hz	4.0	15

#### SPACE REQUIREMENTS:

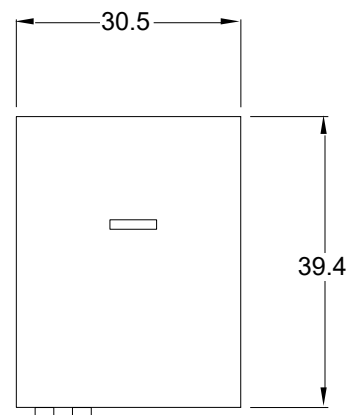
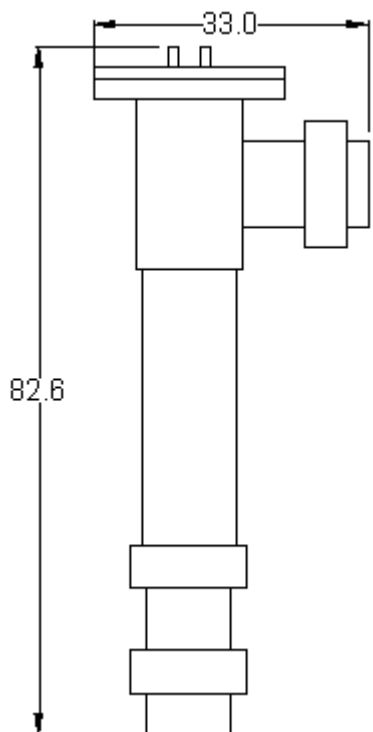



## SECTION 2 INSTALLATION INSTALLATION OVERVIEW

This is a quick guide to how the TMI SALT PURE® zX-5 System should be installed. Refer to the following pages for detailed instructions and helpful hints. If you have any questions, contact TMI before proceeding.

- 1 Locate an appropriate installation location for the zX System 'Cell' in the return line, the location must:
  - a. Be downstream from all other equipment.
  - b. Allow the 'Cell' to be installed vertically (see page 10)
- 2 Mount the Power Supply indoors onto a wall or other rigid surface capable of supporting the 'Power Pack' weight. Power pack should be within reach of the 'Cell' cord connection.
- 3 AC power should only be supplied when the circulation pump is operating. (see page 14 for wiring instructions).
- 4 Connect 'Cell' to Power Supply. (see page 13)
- 5 Install the Flow Meter before the electrolytic cell on the bypass  
\*(follow all manufacturer requirements for run, pipe size, orientation, etc.)
- 6 Install the Mechanical Flow switch before the Electrolytic Cell on the bypass. (see page 12)
- 7 Install SaltSecure® before the electrolytic cell on the bypass.
- 8 When acid is used, connect acid feed on the main line 30 cm (12") before the cell bypass.  
**\*(DO NOT INSTALL ACID INJECTOR BEHIND ISOLATION VALVES)\***
- 9 Add salt to the pool water. Quantity of salt required kilogram (pounds)

Liters X 4.5 / 1000 = kilograms  
(Gallons X 8.35 X (.0035 to .0045) = pounds)

Refer to the following pages regarding type of salt and how to dissolve.

### 2.1 UNPACKING

In the event of damages occurring during shipping, it is the responsibility of the customer to notify the carrier immediately and to file a damage claim. Open the container carefully and examine all material inside. Check against the parts list to be sure that all items are accounted for and intact.

In the event damage occurred, **DO NOT** remove the equipment from the packaging before taking pictures of the box and packaging. Then remove it only to the extent required to photo-document the damage. We recommend ensuring the claim is made to the carrier within 24 hours.

## 2.2 STORAGE

When storing units, use the original packaging and store inside in a dry place. Exposure to excessive humidity, chemical fumes or the elements without protection may lead to damage not covered by the warranty.

## 2.3 SAFETY CONSIDERATIONS

# IMPORTANT SAFETY INSTRUCTIONS READ AND FOLLOW ALL INSTRUCTIONS

## SAVE THESE INSTRUCTIONS

WHEN INSTALLING, OPERATING, AND MAINTAINING THIS EQUIPMENT, KEEP SAFETY CONSIDERATIONS FOREMOST. USE PROPER TOOLS, PROTECTIVE CLOTHING, AND EYE PROTECTION WHEN WORKING ON OR INSTALLING THE EQUIPMENT.

FOLLOW THE INSTRUCTIONS IN THIS MANUAL AND TAKE ANY ADDITIONAL SAFETY MEASURES APPROPRIATE.

BE EXTREMELY CAREFUL IN THE PRESENCE OF HAZARDOUS SUBSTANCES.

THE PERSONNEL RESPONSIBLE FOR INSTALLATION, OPERATION, AND MAINTENANCE OF THIS EQUIPMENT MUST BE FULLY FAMILIAR WITH THE CONTENTS OF THIS MANUAL.

ANY SERVICING OF THIS EQUIPMENT MUST BE DONE WITH THE UNIT FULLY OFF AND DISCONNECTED FROM THE POWER SOURCE AND ALL PRESSURE BLED FROM THE CELL HOUSING ASSEMBLY.

## WARNING

- **TMI SALT PURE® zX-5 SYSTEMS ARE INTENDED TO BE INSTALLED ACCORDING TO ALL LOCAL AND NATIONAL REGULATIONS.**
- **CONNECT THE EQUIPMENT ASSEMBLY TO A CIRCUIT PROTECTED BY A GROUND-FAULT CIRCUIT-INTERRUPTER.**
- **MODIFYING THE TMI SALT PURE® zX-5 SYSTEM IN ANY WAY MAY CAUSE BODILY INJURY AND WILL VOID THE WARRANTY.**
- **DO NOT ALLOW CHILDREN TO OPERATE THE TMI SALT PURE® zX-5 SYSTEM.**
- **ONLY REPLACE COMPONENTS WITH THOSE SPECIFIED BY TMI.**
- **WHEN INSTALLING THE zX SYSTEM, ENSURE THAT POWER IS LINKED TO THE MAIN PUMP POWER SOURCE FOR THE POOL TO ENSURE THAT THE TMI SALT PURE® SYSTEM NEVER OPERATES WHEN THE PUMPS ARE OFF!!**
- **ALL BOXES ON TMI SALT PURE® zX SYSTEM CONTAIN HIGH VOLTAGE COMPONENTS. NEVER OPEN ANY BOX WHILE THE POWER IS ON.**
- **THE SYSTEM HAS THE POTENTIAL TO RELEASE HIGH DOSES OF CHLORINE. USE CAUTION WHEN HANDLING, SERVICING, OR OPERATING THE EQUIPMENT.**
- **DO NOT ENERGIZE OR OPERATE THE SYSTEM IF THE CELL HOUSING IS DAMAGED OR IMPROPERLY ASSEMBLED.**
- **DO NOT MODIFY THE CORD CONNECTED AT TIME OF MANUFACTURE.**

- **DANGER – Risk of injury**
  - Replace damaged cord immediately
  - Do not bury cord
- **WARNING:** To reduce the risk of injury, do not permit children to operate this device.
- **WARNING:** Heavy pool (or spa) usage, and higher temperatures may require higher chlorine output to maintain proper free available chlorine residuals.
- Heavy bather loads may trigger the need for additional salt to be added to maintain an appropriate chlorine residual in the water.
- **DO NOT** add pool or spa chemicals directly to the skimmer. This may damage the cell.
- Maintaining high salt and chlorine levels above recommended range can contribute to corrosion of the pool or spa equipment.
- Check the expiry date of the test kit as test results may be inaccurate if used after that date.
- Follow all aspects of the local and Canadian Electrical Code(s) when installing this device.
- The life expectancy of the electrode is 15,000 – 20,000 hours under normal conditions.
- When replacing the electrode, only use replacement electrodes having a label that clearly states it is a replacement electrode for the chlorine generating device zX-5 Pool Chlorinator, REGISTRATION NUMBER 32769, *PEST CONTROL PRODUCTS ACT*.
- **NOTE:** For outdoor pools, chlorine residuals can be protected from destruction by sun light by addition of stabilizer (cyanuric acid). For proper sanitation, spas should be completely drained periodically. The number of days between **COMPLETE SPA DRAINAGE** is equal to the volume of spa water in litres, divided by 10 times the maximum number of daily spa users. Refill spa with water and repeat **DIRECTIONS FOR USE** of the device.
- **DO NOT USE THIS DEVICE WITH BROMIDE PRODUCTS**

#### Health and Hyperthermia warnings for spa devices:

- People with a medical condition should consult a physician before entering pool or spa water.
- Maximum spa water usage temperature is 40°C. Bathing in spa water at 40°C should not exceed 15 minutes.

## 2.4 PLAN AHEAD

When correctly installed, your Salt Pure® system will operate **ONLY WHEN THE CIRCULATION PUMP IS OPERATING** and water is flowing through the Cell. Your TMI SALT PURE® System must not be able to operate while the filter pump is OFF. This may require use of external relays/contactors, mechanical flow switches or other electrical devices.

### **GENERAL TOOLS NEEDED FOR INSTALLATION** **(Excluding Electrical Installation)**

- **Tape Measure**

- **Phillips & Flathead Screwdrivers**
- **Pliers (Standard and/or Channel Lock)**
- **Reciprocating saw &/or Hacksaw**
- **Electric Drill**
- **Volt Meter to determine line voltage of AC wiring to Power Supply**
- **An NSF® approved PVC/CPVC/ABS Cleaner/Primer**
- **An NSF® approved PVC/CPVC/ABS Cleaner/Cement**
- **Mounting Anchors**

## 2.5 INSTALLATION DIAGRAM WITH SINGLE CELL SHOWN

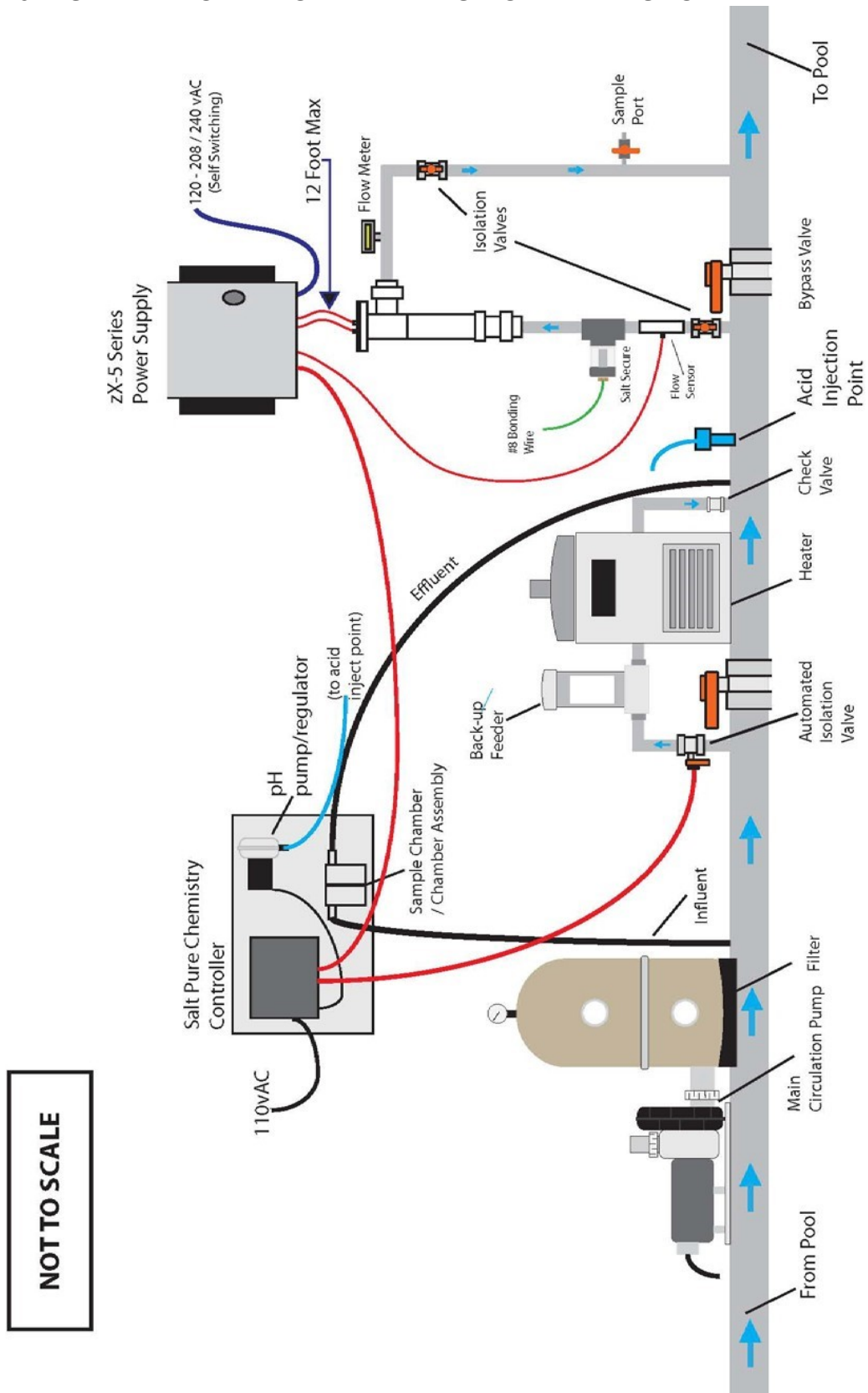

**NOT TO SCALE**

## 2.6 MULTIPLE zX CELL MOUNTING DIAGRAM (IF REQUIRED)

### Multiple zX Cell Mounting

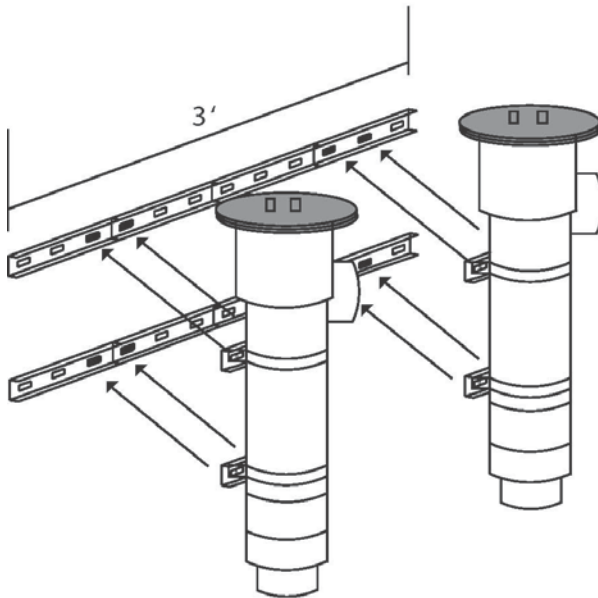

2 Cells will fit on 3' sections of unistrut

PARTS REQUIRED
1 - 10' Stick of Unistrut
4 - 4" Unistrut Clamps
8 - Unistrut Channel Nuts

## 2.7 POWER SUPPLY INSTALLATION

**NEVER TRY TO SUPPORT THE WEIGHT OF THE POWER SUPPLY OR ELECTROLYTIC CELL USING ONLY DRYWALL ANCHORS.**

- Locate a space, in the equipment room, that will accommodate the dimensions of the system.
- Mount the power supply using appropriate hardware.
- The power supply must be installed no more than 3.65 meters (12 feet) from the cell housing to ensure that the cables will reach the cell.
- The Power Supply is not designed to be installed outdoors. If outdoor installation is necessary a shelter providing shade and weather protection will need to be installed.
- It is important to ensure proper air circulation for the Power Supply. Stand-offs on back of Power Supply provide ventilation for wall-mounted units by using factory supplied mounting brackets.

**2.8** Install the acid feed (For the pH Control) approximately 30 cm (12 inches) INFRONT of the cell bypass. This will assist in clearing build up from the cell plates, reducing your ongoing maintenance. **Be sure that the acid will not be injected behind an isolation valve, the system must be able to inject acid even when the cell is offline for maintenance** (see schematics on page 12.)

## **2.9 ELECTROLYTIC CELL INSTALLATION**

### **WARNING**

**THE MOUNTING LOCATION OF THE ELECTROLYTIC CELL MUST BE AT LEAST 1.5 m (5FT) FROM THE POOL.**

The cell housing is equipped with 7.5 cm (3 inch) unions on both sides and is suitable for installation in any return line up to 7.5 cm (3 inch) plumbing. Install the cell in the return line of the pool circulation system. The cell must be installed as the last component in the return line, after all other equipment. It is recommended that isolation valves (not included) be installed for ease of service. Be sure to install the cell in a bypass which will allow the cell to be removed for service (see page 10 for schematic).

## **2.10 FLOW METER INSTALLATION**

Note flow meters should only be used on the size and type of pipe for which they are intended. Follow all installation instructions that accompany the Flow Meter that has been specified for your particular installation. When installing on the cell bypass **INSTALL BEFORE THE ELECTROLYTIC CELL**. We recommend that you use a Digital Flow meter for accuracy (available from TMI) whenever possible.

## **2.11 INSTALLING THE MECHANICAL FLOW SWITCH**

A Mechanical flow switch is included and must be installed before the cell on a straight length of pipe at least 15 cm – 30 cm (6"-12") before and after a bend. The switch will be pre-installed in a 'Tee' of the appropriate size. Remove switch and apply Teflon tape, inspect flow switch beam for damage and housing for any signs of cracks or damage. Reinstall flow switch in the 'Tee' and install assembly into the bypass line.

**Ensure the arrow (on top of the switch) is pointing in the same direction as the water flow before gluing. failure to do so will result in the flow switch not working**

(See page 10)

## **2.12 INSTALLING THE SALTSECURE®**

An in-line zinc anode called SaltSecure® should be installed in-line and will serve as a sacrificial component. It is housed in a 5 or 7.5 cm (2" or 3")(the appropriate size) slip tee with clear PVC for visual inspection.

The SaltSecure® should be glued in-line prior to the electrolytic cell. Install one SaltSecure® per body of water. The anode itself shall have a permanently attached bonding lug which shall be connected to the main bonding loop with a #8 copper wire. **The SaltSecure® is fitted with a manual bleeder valve for the installer to ensure, post startup that the air is removed from the tee and the zinc anode makes contact with the water flow.**

## 2.13 ELECTRICAL SUPPLY - CONNECTING TO AC POWER

- **The pre-installed power cable should be hardwired and connected inside a junction box.**
- The system must be interlocked to the circulation pump operation.
- **The system must be connected to GFCI (GROUND FAULT CIRCUIT INTERRUPTOR)**
- **The zX series power supplies are self-selecting and will operate on the following voltages:**

Voltage (AC)	Phase
120 – 208v	1
240v	1

Refer to **IMPORTANT SAFETY INSTRUCTIONS** at front of these instructions.

## 2.14 CONNECTING CELL TO POWER SUPPLY

The Cell cable is factory-attached to the Power Supply, with connectors at the opposite end meant for field attachment to the cell once installation is complete.

Cable Connector Color	Connection Point
Black	Left Rod
White	Right Rod
Blue	Flow Sensor (small bolt)

**DO NOT CUT OR EXTEND THIS CORD – ANY UNAUTHORIZED MODIFICATION WILL VOID WARRANTY**



## 2.15 SYSTEM WIRING

### **WARNING**

**THE EARTH/GROUND TERMINALS MUST BE CONNECTED.  
THE ELECTRICAL SUPPLY MUST MATCH THE SYSTEM RATED VOLTAGE AND CURRENT.  
ENSURE THAT POWER IS INTERLOCKED TO THE MAIN PUMP'S POWER SOURCE TO ENSURE THAT THE TMI SALT PURE® SYSTEM NEVER OPERATES WHEN THE POOL PUMPS ARE OFF.**

#### **Automated External Control**

Connect a 120 volt power source from chemical feed controller to the terminals in the power supply marked blue neutral and blue line. When connecting to a chemical feed controller, be sure the controller is set to continuous feed and not set on proportional control. Proportional control will reduce the life of power supply components.

#### **Manual Control**

For manual operation, connect a 120 volt power source from a 120 volt AC outlet to the terminals in the power supply marked blue neutral and blue line.

#### **Flow Switch**

Connect the two pin flow switch connector to the two pin terminal labeled FLOW SWITCH.

#### **Cell Cable**

Connect the blue connector from the power supply to the blue connector on the cell.  
**NOTE: Never remove the cables from the top of the cell. Always disconnect the cell with the blue connector.**

## SECTION 3 OPERATION

### 3.1 PREPARING THE WATER

TMI Salt Pure® zX-5 saline chlorination system operates by converting sodium chloride (salt) that has been added to the pool into sodium hypochlorite (liquid chlorine) through electrolysis. In order for the TMI Salt Pure® system to operate salt must be added directly to the pool at least 24 hours before the system is started.

17 kg (37 1/2 pounds) of salt must be added for every 3,800 liters (1,000 gallons) of pool water to reach 4500 ppm (i.e.: a 190000 liters (50,000 gallon) pool will require 816 kg (1800 pounds) of salt or 50 x 18kg (40 pound) bags to reach 4500 ppm). Once the salt has been added, brush the surface of the pool continuously until the salt has dissolved. Never leave large amounts of salt on the surface of the pool or the pool deck.

Only use pure NaCl. Do not use salt with additives. Contact your dealer or TMI for a list of approved salt.

Your pool water should be balanced in the following range before turning your TMI Salt Pure® system on:

	Swimming pool	Spa
Free available chlorine	1.0 – 3.0 ppm	3.0-5.0 ppm
pH	7.2 – 7.8	7.2 – 7.8
Total alkalinity	100 - 120 ppm	100 – 120 ppm
Calcium hardness	200 – 300 ppm	150 – 200 ppm
Salt	3500 - 4500 ppm	3500 – 4500 ppm
Cyanuric acid (stabilizer, used in outdoor pools only)	30 – 100 ppm	30 – 100 ppm
Phosphates	Less than 200 ppb	Less than 200 ppb

Use standard commercial test kits to check water chemistry, and use the supplied conductivity tester to check saline levels.

**(Note that most conductivity testers require frequent calibration to ensure accurate readings, failure to calibrate the equipment will result in inaccurate readings.)**

- If the Calcium Hardness exceeds 500 ppm (parts per million) AND is more than 300 ppm above that of the fill water (tap water), it is recommended that you contact TMI SALT PURE® or your TMI SALT PURE® Dealer for a solution.

- **Adding and Dissolving the Salt**

- 1 Add the salt directly from each bag into the pool water.
- 2 Sweep the salt around the floor toward the main drain to help dissolve and mix,
- 3 A short while after the salt has been added it will no longer be visible, however, the heavier-than-water syrup which forms initially will sit on the floor at the deep end until properly mixed throughout the pool. Dissolve by directing filter suction to the floor drain in the pool (if your pool has one) or by vacuuming the pool.

***NOTE: Newly plastered pools should run on traditional chlorine to “cure” the plaster for at least 2 to 4 weeks before adding the salt. Consult with your builder for exact timing to ensure you do not void your warranty. Be sure to check for calcium buildup in the cell every 2 weeks during “curing” process. See page 22 for directions.***

- **Startup Check List**

Your TMI SALT PURE® System installation is complete when the following have been completed:

- 1 Cell Housing installed into plumbing
- 2 Cell properly secured in place in Cell Housing
- 3 Power Supply mounted in place
- 4 Power Supply connected to main power (correct voltage)
- 5 Cell connected to Power Supply
- 6 SaltSecure®, Flow Switch and Flow Meter installed
- 7 Sufficient salt dissolved into pool water
- 8 You have checked and confirmed that your TMI SALT PURE® System Power Supply switches ON and OFF coincidentally with the circulation pump.
- 9 You have checked all connections and joints for leaks (including Cell head O-ring).
- 10 Acid injection plumbed 30 cm (12”) before cell bypass **(see page 10)**

## 3.2 STARTING THE SYSTEM

Confirm that the salt concentration is 3500 to 4500 PPM.

Confirm that the valves in and out of the cell are in the open position and water is flowing through the cell housing.

Verify system has power.

Ensure that the system is receiving a control signal.

The system will begin generating chlorine at 100% output.

**If the TMI Salt Pure® zX-5 system is linked to a TMI chemical feed controller, leave the system at maximum, unless otherwise directed by a TMI Technician.**

**If the system is being operated manually, adjust the system to find the point at which chlorine levels are maintained to the desired level. This may take several days of monitoring.**

TMI Salt Pure ® zX-5 system connected to a chemistry controller will only operate when the controller is signaling production.

If Proportional Control is used by a chemistry controller, consult TMI Technical Support prior to connecting to zX system.





### 3.3 SYSTEM OPERATION

TMI Salt Pure<sup>®</sup> zX-5 systems operate when both the main power supply cord and control cable have power applied to them. The TMI Salt Pure<sup>®</sup> zX-5 system will continue to operate for as long as power is applied from those two sources.

Chemistry controllers will supply the control cable power to signal production cycles, this can also be done manually by connecting to a constant power source (e.g. 110v outlet)

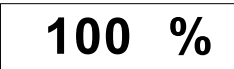
The system has an output range of 0 -100% of the rated chlorine production for the model installed and can be adjusted by pressing the output selector switch on the side of power supply box up or down.

### 3.4 DISPLAY INFORMATION

	During normal operation the display will have the output % displayed:
	A screen scrolling "WAITING FOR CONTROL SIGNAL" is displayed when the system is waiting for a signal from an external source such as a chemistry controller or timer. The system will not generate chlorine until this signal is received.
	The screen below is displayed when the system detects no flow through the electrolytic cell housing. This condition will stop the system from generating chlorine. Once flow is restored, the system will start automatically and this screen will no longer be active.
	This screen is displayed if a low salt condition is present. Any salt concentration <u>below 3000 ppm will stop the system output</u> and display this screen. When the salt concentration is raised above 3000 ppm, reset the system by pressing the output selector switch down once.

## SECTION 4 - MAINTENANCE

TMI Salt Pure® zX-5 systems are designed to operate 24 hours a day and 7 days a week at maximum production rates when the following basic maintenance and cleaning instructions.

### SALT LEVELS:

The zX systems will only operate correctly when is maintained at a minimum 3500 ppm level and a maximum of 4500ppm. Adjust the salt concentration as often as needed to maintain the desired level.

***(Low salt will lower the amount of chlorine produced and will cause damage to the electrolytic cell. Warranties will not be honored if it is determined that salt has been run low.)***

### CELL INSPECTION:

Visually inspect the cell housing for leaks and the cell stack for calcium build up regularly. Check the connections at the top of cell monthly and clean as needed.

**Clean the cell when calcium buildup is present.**

### FLOW SWITCH:

The zX system is equipped with an integrated mechanical flow switch which must be tested periodically to ensure proper operation. It is recommended to test the flow switch for proper operation at least once a month.

To test the flow switch:

- Close the lower cell isolation valve stopping flow to the cell.
- Immediately check the unit to see if it shut down.  
***\*This should shut the unit down\****
- If unit shuts down, reopen valve and resume normal operation.
  
- If unit does not shut down,
- Immediately open the valve.  
***\*Do not allow the system to operate with the valve closed.\****
- Inspect and repair/replace a defective flow switch immediately.

# Cleaning the cell

To clean the cell,

1. Disconnect power from the zX system,
2. Stop the pool circulation system flow.
3. Open the Bypass Valve
4. Close the lower cell isolation valve and then close the upper cell isolation valve. Disconnect the cables from electrolytic cell.
5. Remove the bolts holding the electrolytic cell stack in the cell tube and lift the cell out of the cell tube.
6. Immerse the cell in a cleaning solution made of 1 part acid to 4 parts water.
7. Leave the cell in the muriatic acid solution for 15-20 minutes or until bubbling stops. Rinse the cell and repeat as needed until the cell is clean.  
**Do not leave the cell in the muriatic acid solution any longer than necessary to clean the cell.**
8. Reassemble the cell stack in the tube and reconnect the cables to the top of the cell stack.
9. Place Valve back in original position.

## !!WARNING!!

Read all cautions and directions provided with the muriatic acid used. Always add acid to water never the other way around. Use only with adequate ventilation. If strong odor is noticed, STOP and leave area immediately, ventilation is inadequate. If the work area is not well ventilated, you MUST use a properly fitted and maintained NIOSH approved respirator for acid fumes.

Leaving the cell immersed in the water/acid solution for longer than 20 minutes could damage the ruthenium coating and this will void the warranty.

# TECHNICAL & TROUBLESHOOTING GUIDE

## TMI Salt Pure® zX-5





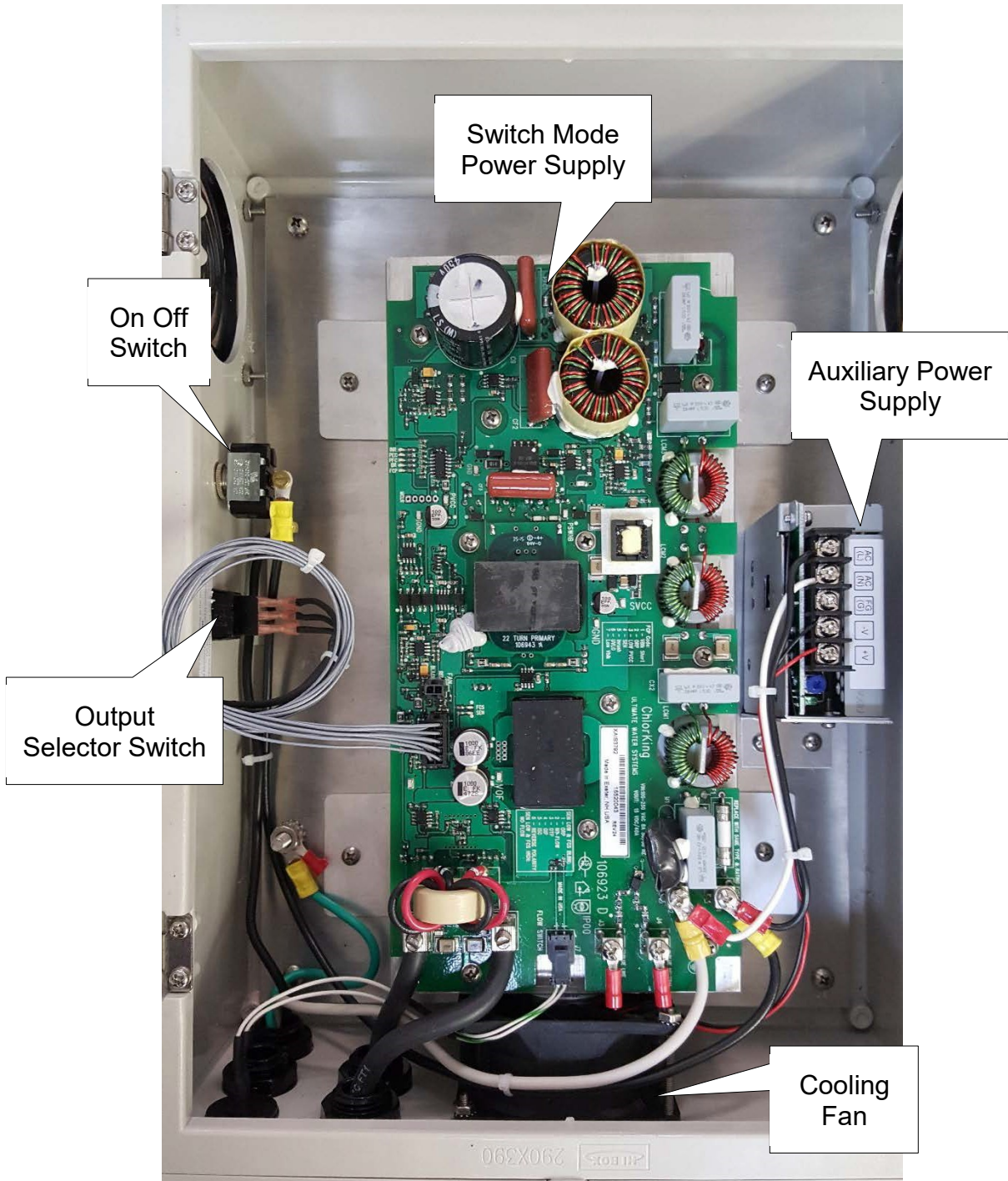

Switch Mode Power Supply

On Off Switch

Auxiliary Power Supply

Output Selector Switch

Cooling Fan

# Component Description

## **Power Pack**

The power box houses all of the components required to convert the available voltage to a DC voltage suitable to operate the electrolytic cell.

## **Electrolytic Cell**

The electrolytic cell converts salt and water to chlorine.

## **On-Off Switch**

The on-off switch signals the unit to turn on-off (power to cell).

**Note: it does not interrupt line power**

## **Output Selector Switch**

The output selector switch is used to adjust the system output to the desired level.

## **Switch Mode Power Supply**

The power supply controls the output to the electrolytic cell. The power supply is also responsible for reversing polarity to the cell for the purpose of reducing scale buildup and limiting the frequency of manual cleaning by the user. The power supply contains the system safety features such as overvoltage monitoring for low salt detection and temperature monitoring for power supply protection. The module is equipped with LED lights for visual indication of module state.

## **Auxiliary Power Supply**

The auxiliary power supply is for operating the cooling fan.

## **Cooling Fan**

The cooling fan keeps the switched mode power supply under the maximum operating temperature.

## **LCD**

The display relays system status to the user.

# **TROUBLESHOOTING GUIDE**

This guide was designed to assist in troubleshooting the TMI Salt Pure® zX-5. The guide is laid out in two main sections, *Quick Checks* and *Troubleshooting with LCD Message Screens*. Each section was designed to solve a specific level of problem. Diagnosis should always start with the Quick Checks, followed by Troubleshooting with LCD Message Screens. Skipping any section may result in misdiagnosis and wasted time. Some sections may seem repetitive. This is in an effort to ensure consistent findings.

## **QUICK CHECKS**

The following list contains common issues that should always be checked prior to any in-depth troubleshooting, or calling in for support.

1. Calibrate your conductivity meter.
  - Verify the salt concentration in the pool is between 3500ppm and 4500ppm.
2. Verify that the control cord is wired to a power source with available voltage of 120 to 240 VAC.
3. Verify that the on-off switch is in the on position or the up position.
4. Verify that the fan is operating.
5. Verify that there sufficient water flow through the flow switch and cell housing.

# Troubleshooting LCD Message Screens

The following section provides an explanation of the LCD screen to help identify the most common problems encountered with the TMI Salt Pure® chlorine generator.

During normal operation the display will have the output % displayed. This system is functioning normally.

**100 %**

A screen scrolling "WAITING FOR CONTROL SIGNAL" is displayed when the system is waiting for a signal from an external source such as a chemical feed controller. The system will not generate chlorine until this signal is received.

# CONTROL

If you see this screen, the following has occurred:

1. The chemical feed controller is not calling for feed.
2. A voltage signal is not present at the control input.

Diagnostic Procedure:

1. Verify the control cord is installed in the power supply and connected to the control input terminals marked “blue line”.
2. Verify the control cord is connected to a voltage source capable of supplying a minimum of 120 VAC and a maximum of 240 VAC or a chemical feed controller.
3. If connected to a chemical feed controller, verify that the controller is calling for feed.
4. Check for 120 to 240 VAC across the two terminals marked blue line.
  - a. If voltage is not available, the problem is with the voltage source.
  - b. If voltage is available, reset the system by turning the power off and then on again.
5. If the problem is not resolved, contact TMI for further assistance at [techsupport@tmisaltpure.com](mailto:techsupport@tmisaltpure.com).

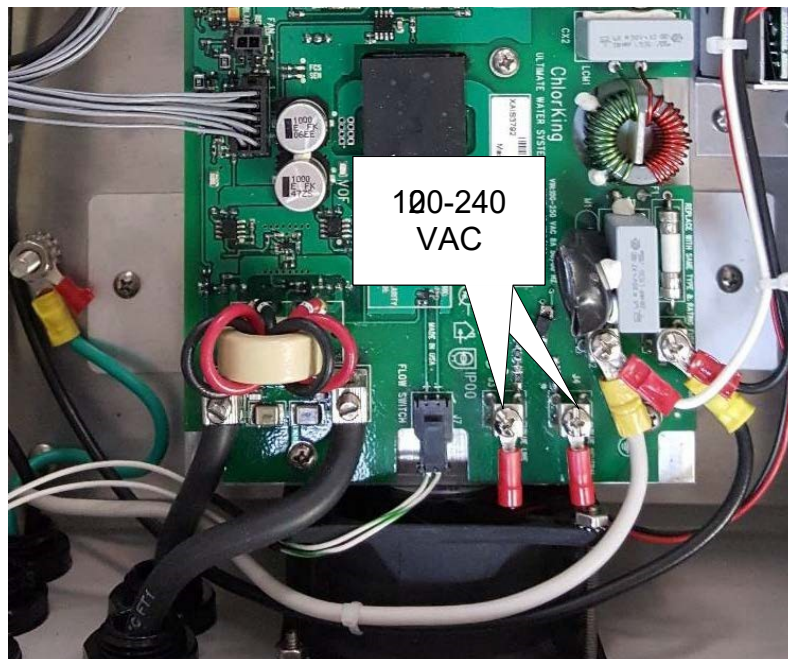

The screen below is displayed when the system detects no flow through the electrolytic cell housing. This condition will stop the system from generating chorine. Once flow is restored, the system will start automatically and this screen will no longer be active.

**NO FLOW**

If you see this screen, the following has occurred:

1. The flow switch has shut the system off.

Diagnostic Procedure:

1. Check for adequate flow through the cell housing. A minimum of 100 lpm (25 gpm) is necessary to activate the flow switch. If flow is confirmed go to the next step.
2. Check the flow switch by removing the flow switch connector from the outside of the power supply and testing for continuity across the two pins of the connector.
  - a. If there is no continuity measured, replace the flow switch.
  - b. If continuity is measured, go to the next step.
3. Disconnect the two pin connector from the internal connection at the power supply and test for continuity across the pins of the connector.
  - a. If there is not continuity measured, replace the flow switch wiring harness.
  - b. If continuity is measured, contact TMI for further assistance at [techsupport@tmisaltpure.com](mailto:techsupport@tmisaltpure.com).

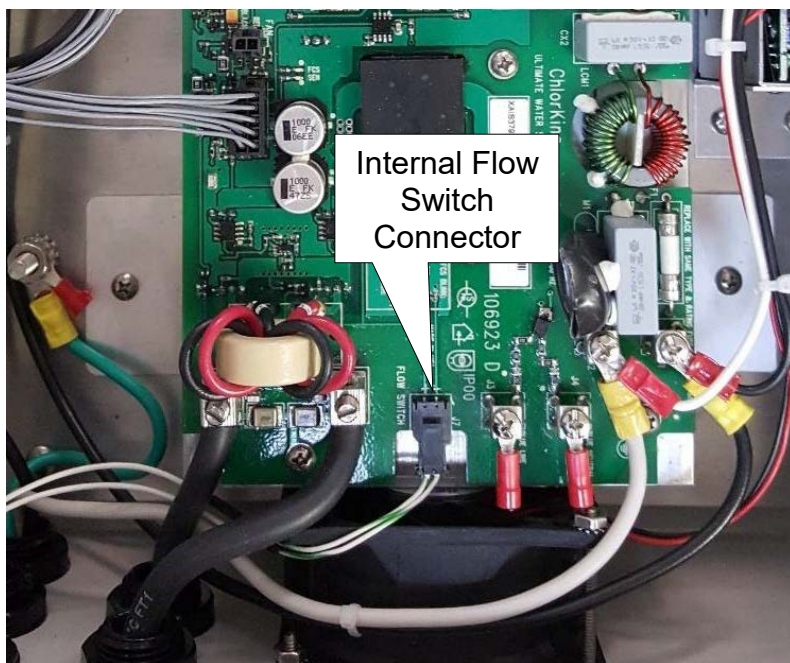

This screen is displayed if a low salt condition is present. Any salt concentration below 3000 ppm will stop the system output and display this screen. When the salt concentration is raised above 3000 ppm, reset the system by pressing the output selector switch down once.

**LOW SALT**

If you see this screen, the following has occurred:

1. High output voltage to the electrolytic cell caused by low salt a dirty or failed electrolytic cell has shut the system off.

Diagnostic Procedure:

1. Test the salt content in the pool. If salt is low, correct it by adding the appropriate amount of salt. The correct salt concentration is 3500 to 4500ppm.
2. Visually inspect the electrolytic cell for signs of contamination. Calcium contamination can be seen as white buildup on the cell plates. Clean the cell (see 'cleaning the cell' on page 20).
3. Visually inspect the cable connections for corrosion. Corroded cable need to be cleaned with a wire brush or replaced.
4. Reset the low salt condition by pressing the output selector switch on the front of the power supply down once. The system will begin generating. If the output selector cannot be used to reach 100% output, replace the electrolytic cell.

This screen is displayed if the power supply overheats from a lack of air flow.

**OVERTEMP**

If you see this screen, the following has occurred:

1. The power supply has overheated.

Diagnostic Procedure:

1. Confirm that the cooling fan is functional and that the inlet and outlet air vents are not obstructed. If the fan is not functional, go to the next step.
2. Check for 120 to 240 VAC across the white and black wires on the auxiliary power supply shown on the next page.
  - a. If voltage is not available replace the wire harness (see page 26) from the switch mode power supply to the auxiliary power supply.
  - b. If voltage is available, go to the next step.
3. Check for 12 VDC across the red and black wires on the auxiliary power supply.
  - a. If 12 VDC is not available, replace the auxiliary power supply.
  - b. If 12 VDC is available replace the fan.

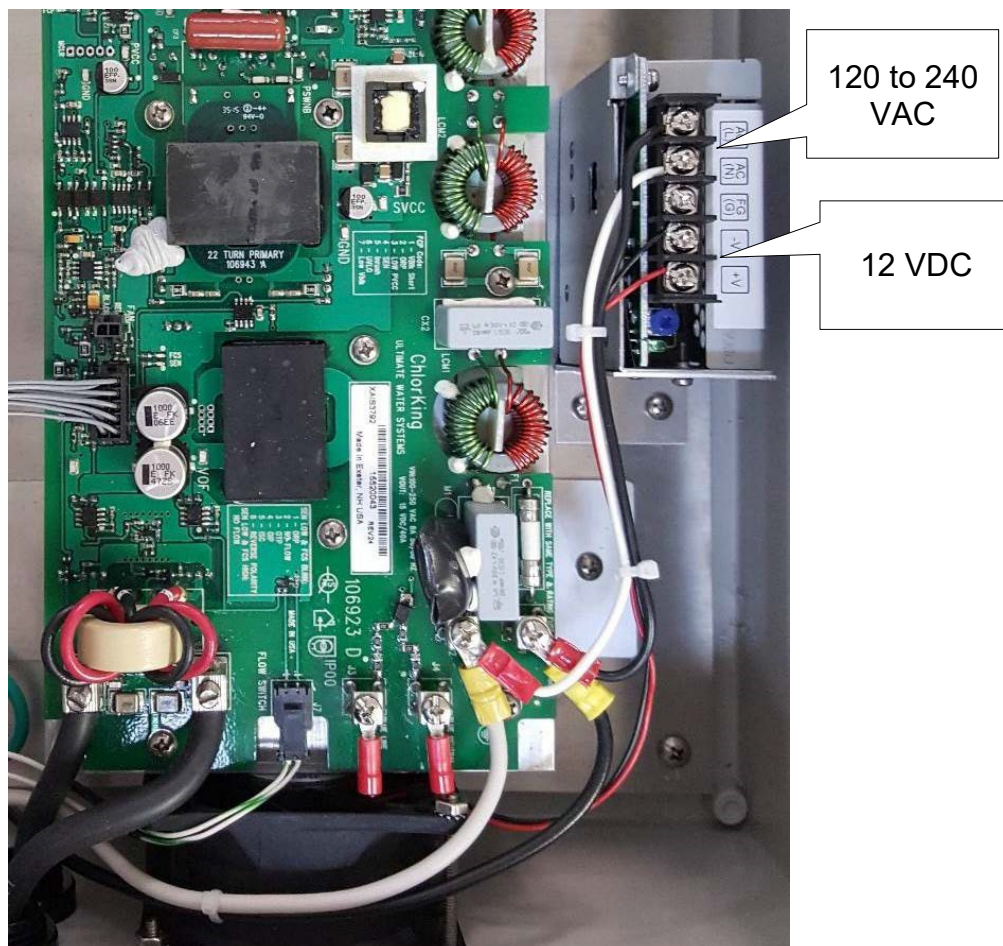



[BLANK SCREEN]



Diagnostic Procedure for a blank screen:

1. Verify that the power supply is plugged in or wired to a power source with 120 to 240 VAC available.
2. Verify that the on-off switch is in the on or up position.
3. Check for 120 to 240 VAC at the input connectors or the power supply shown in the photo below.
  - a. If voltage is not available, the problem is with the supply voltage.
  - b. If voltage is available, reset the system by turning the on-off switch off and on again.
  - c. If the problem is not resolved contact TMI for further assistance at [techsupport@tmisaltpure.com](mailto:techsupport@tmisaltpure.com).

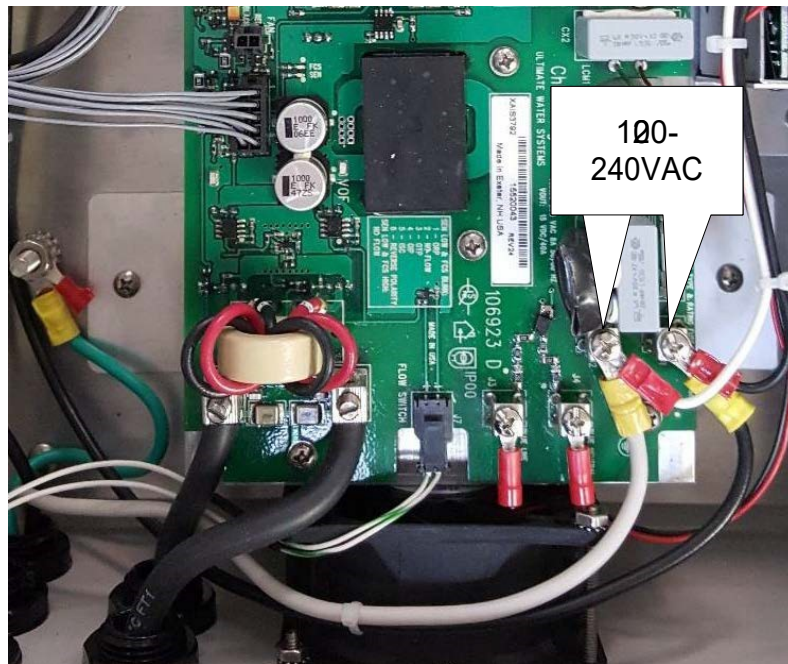

## SECTION 6

### WARRANTY INFORMATION

The TMI® Salt Pure zX-5 system carries a limited 3-year warranty

**3 Year** warranty on assembly of electrical components and cell housing.

**2 Year**, pro-rated, on titanium electrodes. (Year 1 is warranted fully, thereafter pro-rated warranty applies, applicable over the full 2-year period. Applicable on electrode stacks where full price has been paid.)

**1 Year** on all electrical items.

TMI® advises that titanium electrodes will have to be replaced every 3 years of operating time.

TMI® warranties will not be honored should it be shown that the operating and maintenance procedures have not been followed, particularly with regard to the cleaning frequency program.

TMI® warranties of the titanium electrodes will not be honored if the system is operated in water temperatures lower than 15°C (59°F).

TMI® warranties of the titanium electrodes may not be honored if the system is operated under conditions not originally approved by TMI® on a System Design Sheet, with regard to operating hours, swimmer usage or excessive use of stabilizers or stabilized chlorine.

TMI® warranties of the titanium electrodes will not be honored if the system is operated where phosphates exceed 250ppb – 500ppb consistently.

An installation & commissioning form must be submitted to TMI for warranty to be validated. Failure to submit a commissioning form may result in warranty being void.

During the warranty period the customer shall return the defective component, freight prepaid, accompanied by the original invoice or proof of purchase, and TMI® shall at its sole discretion elect to repair or replace the defective component and return it to the customer, freight prepaid.

TMI® accepts no responsibility other than to repair or replace a defective component, and this warranty specifically excludes product failure due to accidental damage, abuse, misuse, and negligence, damage due to non-compliance of the operating manual or unauthorized alterations or modifications to the system. TMI® accepts no responsibility and is not liable for any extended warranties or variations to this warranty offered by re-sellers of TMI® systems.

# Parts Guide

## TMI Salt Pure® zX-5



Note: This manual is subject to change at any time based on system improvements, design changes, authorized modifications or new information. Please consult TMI for the latest revision.

# Power Box – Inside

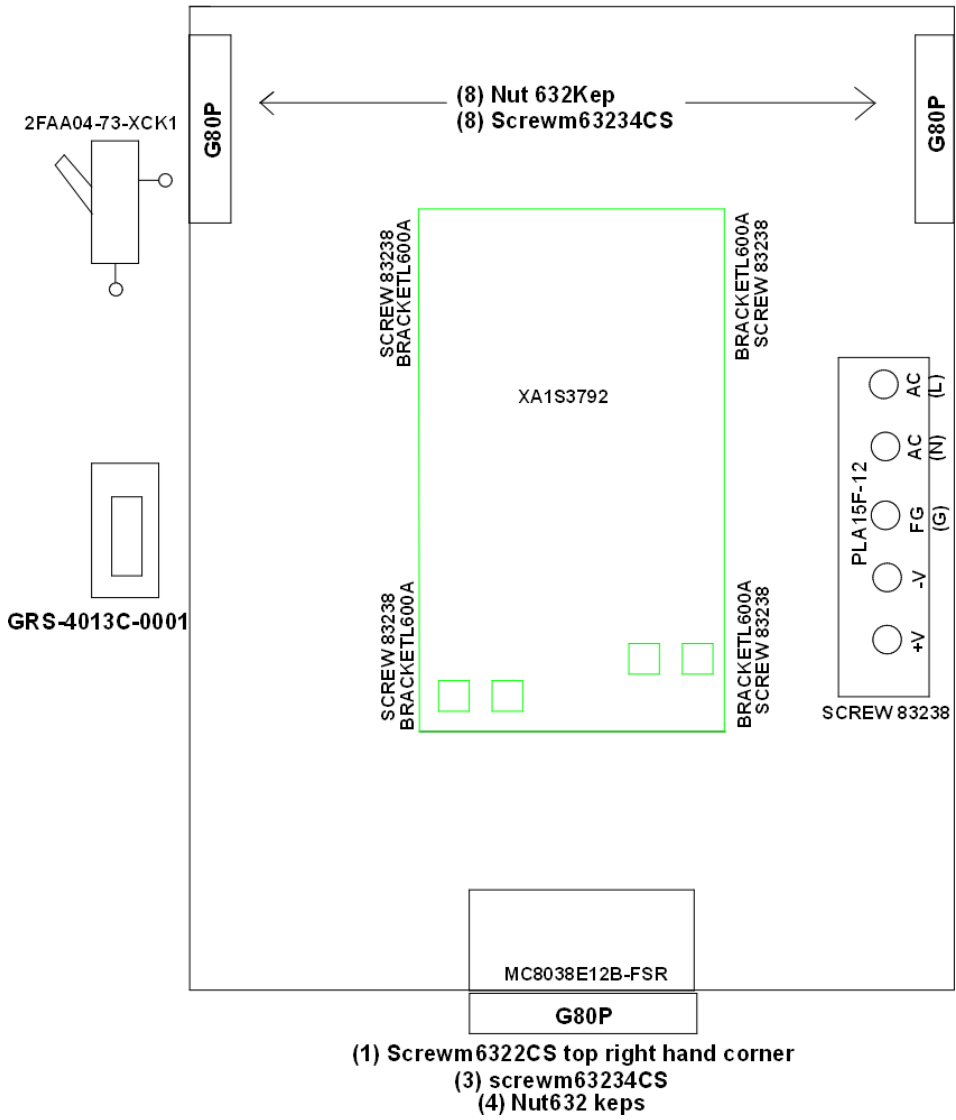

## PART IDENTIFICATION

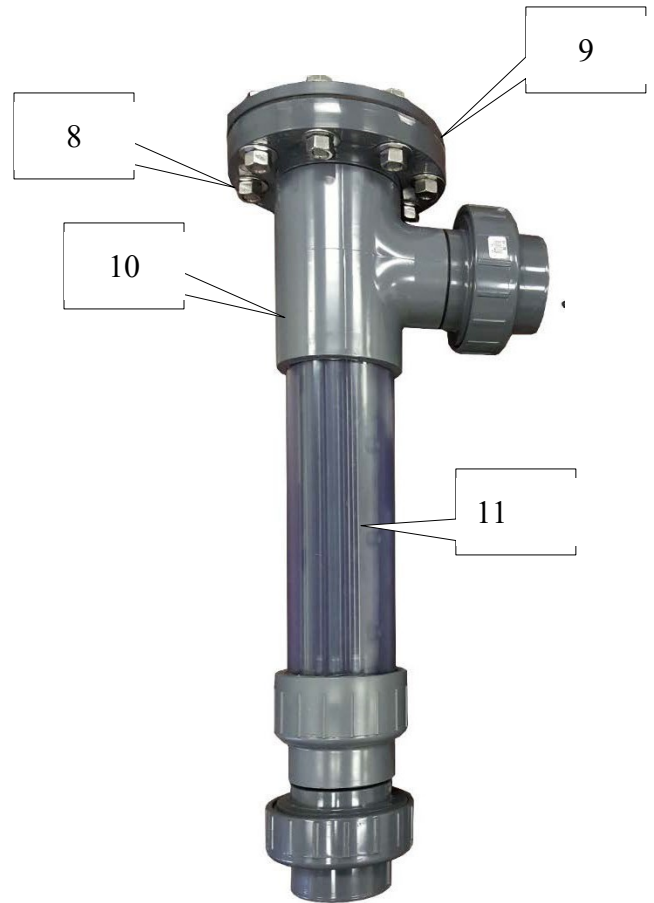
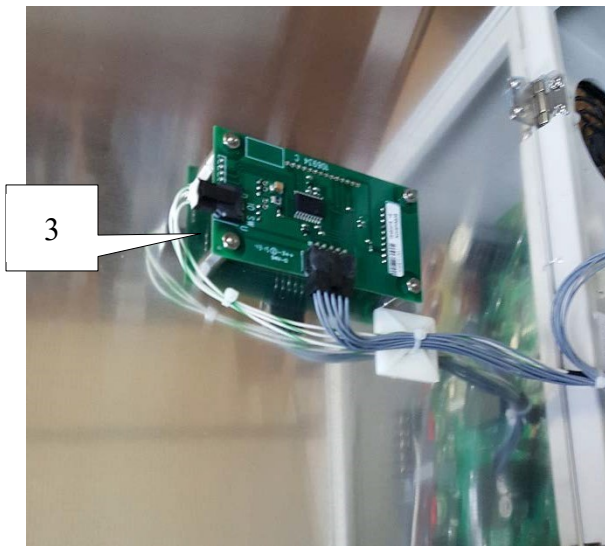
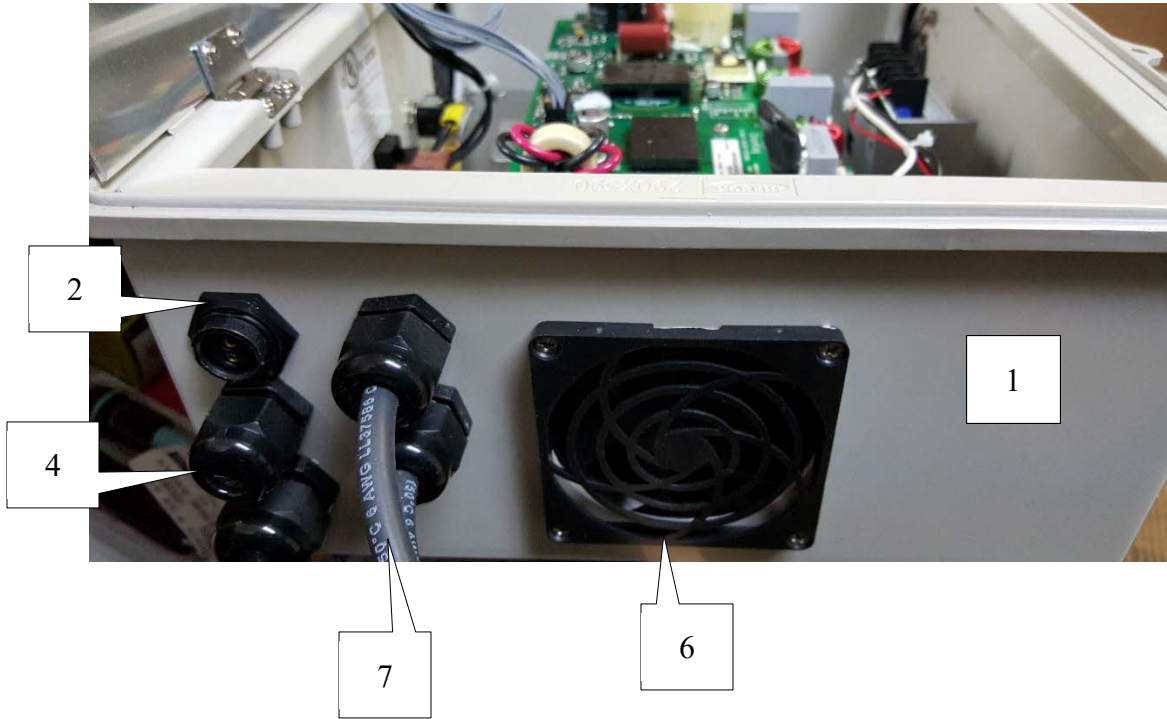

#	Description	Part Number
1	Enclosure	ZX0001
2	Connector 2 Pin with Harness	ZX0002
3	LCD Display	ZX0003
4	Liquid Tight Gland	ZX0004
5	Liquid Tight Gland Lock Nut (Not Shown)	ZX0005
6	Vent	ZX0006
7	Harness to Cell	ZX0007
8	Bolt Kit for Cell Tube	ZX0008
9	Cell Gasket	ZX0009
10	Cell Tube	ZX00010
11	Electrode Stack 5.0TMI (shown inside tube)	ZX00011
12	Flow Switch (Not shown)	ZX00012

## Salt Pure® System Installation & Commissioning Form

INSTALLER: PLEASE COMPLETE ONE FORM FOR EVERY POOL ON THE PROJECT

Facility

Address

City  State  Zip Code

PLEASE FAX BACK TO:  
(360) 871-6871  
OR  
SCAN AND EMAIL TO:  
techsupport@tmisaltpure.com

Installer  Company

### POOL INFORMATION

Pool Name	<input style="width: 100%; height: 20px;" type="text"/>		
Gallons	<input style="width: 100%; height: 20px;" type="text"/>	Fill Date	<input style="width: 100%; height: 20px;" type="text"/>
Flow Rate	<input style="width: 100%; height: 20px;" type="text"/>	Date circulation started	<input style="width: 100%; height: 20px;" type="text"/>
Salinity	<input style="width: 100%; height: 20px;" type="text"/>	Date pool Salted	<input style="width: 100%; height: 20px;" type="text"/>

### EQUIPMENT INFORMATION

Controller - Model	<input style="width: 100%; height: 20px;" type="text"/>	Install Date	<input style="width: 100%; height: 20px;" type="text"/>
Controller - Serial #	<input style="width: 100%; height: 20px;" type="text"/>	Start Up Date	<input style="width: 100%; height: 20px;" type="text"/>
Salt System - Model	<input style="width: 100%; height: 20px;" type="text"/>	Install Date	<input style="width: 100%; height: 20px;" type="text"/>
Salt System - Serial #	<input style="width: 100%; height: 20px;" type="text"/>	Start Up Date	<input style="width: 100%; height: 20px;" type="text"/>
UV System - Model	<input style="width: 100%; height: 20px;" type="text"/>	Install Date	<input style="width: 100%; height: 20px;" type="text"/>
UV System - Serial #	<input style="width: 100%; height: 20px;" type="text"/>	Start Up Date	<input style="width: 100%; height: 20px;" type="text"/>
Chlorine BackUp - Model	<input style="width: 100%; height: 20px;" type="text"/>	Install Date	<input style="width: 100%; height: 20px;" type="text"/>
Chlorine BackUp - Serial #	<input style="width: 100%; height: 20px;" type="text"/>	Start Up Date	<input style="width: 100%; height: 20px;" type="text"/>

The purpose of this document is to verify the proper installation and start date of the equipment. Warranty will be tied to this start date. If this form is not filled out and submitted within 30 days of installation, warranty will begin on date of purchase.

Purchase Date  Invoice #

Equipment warranties begin on startup dates provided above. Start Up dates verified on:

TMI Salt Pure Corporation: \_\_\_\_\_ Company: \_\_\_\_\_

Signed: \_\_\_\_\_ Signed: \_\_\_\_\_

Name: \_\_\_\_\_ Name: \_\_\_\_\_

### Salt System -Install Checklist

- Power Supply securely mounted
- Cell installed / Mounted per manual instructions
- Cell Bypass includes: main line diversion valve, 2 isolation valves (one on each leg of bypass), and unions at the cell
- AC Power within specified range
- Salinity within specified range
- Flow through Cell bypass within specified range
- Flow Meter installed on cell bypass - before cell
- Mechanical Flow switch installed on bypass - before cell
- Salt-Secure Installed on cell bypass. - before cell

### UV System - Install Checklist

- AC Power supplied - within specs noted in Manual
- Reactor installed / Mounted per manual instructions
- Flanges provided with UV system are used for install, plumbing is not glued directly to reactor
- Flow through UV bypass within optimal range for unit - per manual
- Flow Meter installed on UV bypass
- UV Bypass includes: main line diversion valve, 2 isolation valves (one on each leg of bypass)

### Controller - Install Checklist

- AC Power supplied - within specs noted in Manual
- Flow through flow cell has been adjusted to approximately 12 - 14 GPH (Read at flow cell #1)
- Flow cell sample lines are installed Pressure / Pressure (before and after heater preferred, before and after filter also works when necessary.) - *Contact TMI if neither option is possible.*
- Sensors are installed in accordance with labeling. - \*(Picture required by TMI prior to completion )
- Chemistry AC Pigtails are labeled but not connected to Acid or Chlorine systems prior to TMI authorization
- External Control Wire(s) run between controller and Salt Pure system \*(But not connected)
- Where PPM sensors are provided, electrolyte gel will be left with controller or handed to operator.

### Chlorine BackUp - Install Checklist

- AC Power Supplied / Power Adaptor Connection - within specs noted in Manual
- Inlet and Outlet lines installed per installation diagrams in manual
- Flow Meter provided with system installed on bypass
- Flow through bypass within required range for proper operation as outline in the manual

- ALL INSTALL INSTRUCTIONS IN THE PROVIDED EQUIPMENT MANUAL(S) HAVE BEEN FOLLOWED\*

Installer

Company

Date

THIS INSTALLATION CHECK LIST SERVES AS A BASIC GUIDE FOR THE COMMON AREAS OF INSTALLATION THAT MUST BE ADDRESSED. THIS IS NOT A COMPREHENSIVE SET OF INSTRUCTIONS. PLEASE REFER TO THE INSTALLATION INSTRUCTIONS IN THE MANUALS PROVIDED WITH EACH PIECE OF EQUIPMENT PRIOR TO STARTING THE INSTALL.

\* BY CHECKING OFF "ALL INSTALL INSTRUCTIONS IN THE PROVIDED EQUIPMENT MANUAL(S) HAVE BEEN FOLLOWED" INSTALLER AGREES TO CORRECT ANY ISSUES FOUND WITH INSTALLATION THAT ARE EXPLICITLY ADDRESSED IN THE INSTALLATION INSTRUCTION SECTION(S) OF THE MANUAL(S) PROVIDED BY TMI SALT PURE\* CORP.