

2024-1325
2024-08-06

HYPROLYSER 560
Chlorine Generator

Controls Bacteria and Algae in
Commercial Swimming Pool (Spa) Waters

A maximum of 1,160,000 L of water can be treated with one Hyprolyser 560 unit.
Maximum output of hypochlorous acid equivalent to 13.4 kg of free available chlorine per day

For swimming pools, a range of 1-3 ppm of free available chlorine must be maintained.
For spas, a range of 3-5 ppm of free available chlorine must be maintained.

READ THE LABEL AND OPERATING MANUAL BEFORE USING
KEEP OUT OF REACH OF CHILDREN
REGISTRATION NO. 33146 *PEST CONTROL PRODUCT ACT*

WARNING: Operating a Hyprolyser 560 without water flow through the cell can cause a buildup of flammable gases which can result in FIRE OR EXPLOSION.

NOTICE TO USER: This pest control product is to be used only in accordance with the directions on the label. It is an offence under the *Pest Control Products Act* to use this product in a way that is inconsistent with the directions on the label.

Pinnacle Aquatic Group Inc.
5423 61 Ave SE Unit 140
Calgary AB T2C 5N7

HYPROLYSER 560
560 Electrolyser Replacement Cell

Replacement cell for the Hyprolyser 560 chlorine generating device.
REGISTRATION NUMBER 33146, *PEST CONTROL PRODUCTS ACT*. This cell must only be used on this model of chlorine generating device.

Read the Label, the Installation Manual and Operation Manual of the Hyprolyser 560 chlorine generating device before using.

Pinnacle Aquatic Group Inc.
5423 61 Ave SE Unit 140
Calgary AB T2C 5N7



Hyprolyser® 560

Electrolysis system for on-site hypochlorite generation



User Guide

EN

Read and refer to the operation and maintenance instructions before start-up!

To be held for further reference.

TABLE OF CONTENTS

INTRODUCTION.....	5
SAFETY INFORMATION... ..	6
INTENDED USE / WARRANTY INFORMATION	7-8
PRODUCT DESCRIPTION... ..	9-10
TECHNICAL DATA.....	11-13
INSTALLATION.....	14-18
START UP.	19-20
OPERATION... ..	21
MAINTENANCE AND CLEANING... ..	22-27

On-site Electrolytic Chlorination System, Hypolyser Model 560, 1100, 2200

HYPOCHLORITE GENERATION
CONTROLS BACTERIA AND ALGAE
in
Swimming Pool (and Spa) Waters

COMMERCIAL

For swimming pools, a range of 1.0 – 3.0 ppm of free chlorine
must be maintained.

For spas, a range of 3.0 – 5.0 ppm of free available chlorine
must be maintained.

KEEP OUT OF REACH OF CHILDREN

READ THE LABEL AND OPERATION MANUAL BEFORE USING

REGISTRATION NO. 33146 PEST CONTROL PRODUCT ACT

WARNING: Operating the *On-site Electrolytic Chlorination System, Hypolyser Model 560, 1100, 2200*, without water flow through the cell can cause a buildup of flammable gases which can result in FIRE OR EXPLOSION.

NOTICE TO USER: This pest control product is to be used only in accordance with the directions on the label. It is an offence under the *Pest Control Products Act*, to use this product in a way that is inconsistent with the directions on the label.

Pinnacle Aquatic Group Inc. 5423 61 Ave SE Unit 140, Calgary, Alberta, T2C 5N7 Canada.
Tel. 1 (403) 453-1944 Email: info@pinnacleaquaticgroup.com Web: www.pinnacleaquaticgroup.com

Introduction

This user manual provides significant assistance in the successful and smooth running of the Hyprolyser® electrolysis systems, also referred to, in short, as “system” in the following instructional text.

The operating manual for the Hyprolyser® electrolysis systems must always be available where the system is located and has to be read and used by every person who is assigned to working on the system. This includes amongst other things:

- the installation
- the servicing and repair work
- the maintenance (maintenance, care, repair)
- the transport

All documents are protected in the sense of the copyright law. It is forbidden to forward on and copy the documents, even in part, as well as to use and communicate their contents, insofar as this is not expressly conceded in writing. Violations are punishable and incur an obligatory payment of damages. Pinnacle Aquatic Group Inc. reserves all the rights for the practice of industrial property rights.

The operating manual is a significant component of the Hyprolyser® electrolysis system. The operator must ensure that the service personnel learn these guidelines.

The operating manual is to be supplemented by the operator regarding the operating instructions, national regulations for Health and Safety at Work and Environmental Protection, including information on the responsibilities of supervision and the observance of operational specifics, e.g. concerning labor organizations, operational sequences and appointed personnel.

Besides the operating manual and the obligatory regulations for Health and Safety at Work applicable in the country of use, as well as in the place of use, the recognized specialist technical regulations for safe and professional work must also be observed.

The operator of the Hyprolyser® system may not make any changes, attach fittings or make alterations to the construction of the Hyprolyser® system that may impair security, without the written consent of Pinnacle Aquatic Group Inc. This also applies to the installation and setup of safety devices.

Any replacement parts to be used must correspond to the technical requirements specified by Pinnacle Aquatic Group Inc. This is always guaranteed in the case of original spare parts.

Safety Information

General Warnings

The following warnings are intended to help you to eliminate the dangers that can arise while handling the device. Risk prevention measures always apply regardless of any specific action. Safety instructions warning against risks arising from specific activities or situations can be found in this Operation Manual.

Hazards Due To Non-Compliance with the Safety Instructions

Failure to follow the safety instructions may endanger not only persons, but also the environment and the device.

- failure of important functions of the device and of the corresponding system
- failure of required maintenance and repair methods
- danger to persons

Working In a Safety-Conscious Manner

Besides the safety instructions specified in these operating instructions, further safety rules apply and must be followed:

- accident prevention regulations
- safety and operating provisions
- environmental protection provisions
- applicable standards and legislation

Personal Protective Equipment

Based on the degree of risk posed by the dosing medium and the type of work you are carrying out, you must use corresponding protective equipment. Although the dosing media produced by the Hypolyser® System is classified non-hazardous, the following protective equipment is recommended when carrying out certain tasks:

- Commissioning
- Working on pressurized dosing devices
- Shutdown
- Maintenance
- Disposal

Personnel Qualification

Any personnel who work on the device must have appropriate knowledge and skills. Anybody who works on the product must meet the conditions below:

- attendance at all the training courses offered by the owner
- personal suitability for the respective activity
- sufficient qualification for the respective activity
- training in how to handle the device
- knowledge of safety equipment and the way this equipment functions
- knowledge of these operating instructions, particularly of safety instructions and sections relevant for the activity
- knowledge of fundamental regulations regarding health and safety and accident prevention.

All Persons Must Generally Have the Following Minimum Qualification

- training as specialists to carry out work unsupervised on the device
- sufficient training that they can work on the device under the supervision and guidance of a trained specialist

Intended Use / Warranty Information

Notes on Product Warranty

Any non-designated use of the device can impair its function and the protection provided. This leads to invalidation of any warranty claims! Please note that liability is on the side of the user in the following cases:

- The device is operated in a manner which is not consistent with these operating instructions, particularly safety instructions, handling instructions and the section "Intended Use".
- Information on usage and environment (see section "Technical Data") is not adhered to.
- Personnel that operate the device who are not adequately qualified to carry out their respective activities.
- Unauthorized spare parts or accessories of Pinnacle Aquatic Group Inc. are used.
- Unauthorized changes are made to the device.
- The user uses different salt quality than that indicated in this instruction manual.
- Maintenance and inspection intervals are not adhered to as required or not adhered to at all.
- The device is commissioned before it or the corresponding system has been correctly and completely installed.
- Safety equipment has been bridged, removed or made inoperative in any other way.

Intended Purpose

The HYPROLYSER® on-site electrolytic chlorination system is intended for the following purpose: Generation of a <1% sodium hypochlorite solution using salt, water and electrical energy, with the resulting media to be used as a disinfection agent for the chlorination of drinking water and swimming pools. The concentration of the sodium hypochlorite solution produced is 0.6% (+/-0.1%) Cl₂ by weight.

Device Revision

This operating instruction manual applies to the following devices:

Device	Month /year of manufacture
Hyprolyser®	10/2014 onwards

Sodium Chloride Chemical Specification

The Hyprolyser® system is designed to be used with dry crystalline/granular salt. Salt can be purchased in bulk/ pallet quantities to obtain best economy. When ordering salt from your supplier always specify the brand or specific quality you require, so that in the unlikely event of any shortage of stock, you will still receive an equivalent grade of salt. *Use dry crystalline/granular salt that is pool quality grade*

Water Quality

Drinking water or water of a similar quality should be used. It should be free of solids and suspended matter. The temperature of the water entering the system must be in the range of 5-20°C.

Standard Warranty Conditions

Equipment	Warranty Period
Electronic devices	2 years
Electrolyser	5 years limited, pro-rata
Wearable items	12 months

Product Description

Scope of Delivery

Please compare the delivery note with the scope of delivery:

- HYPROLYSER® system
- Operating Instructions
- Optional - dosing pump/s, accessories.

Design and Function

Structure of the Device

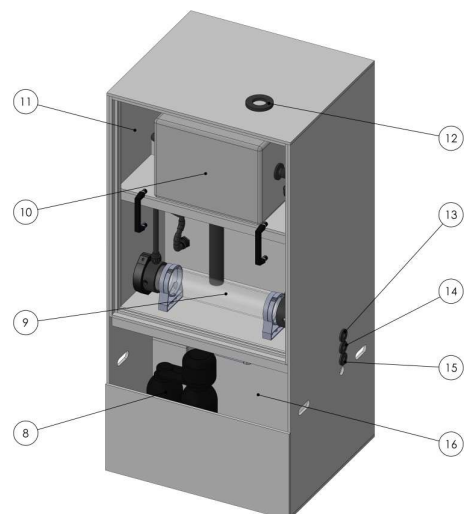
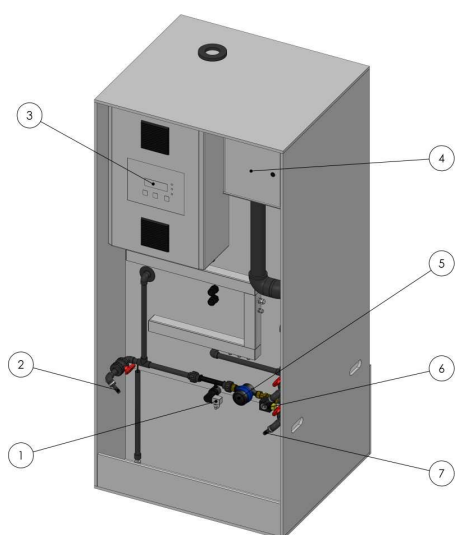

Item	Description
1	Brine control
2	Diluted brine / salinity S.G. sample point
3	Control panel
4	Centrifugal ventilation fan
5	Feed water flow management
6	Product strength sample point
7	Softened feed water sample point
8	Softener system
9	Electrolyser
10	Integral product storage & degassing tank
11	Sealed electrolyser compartment
12	Ventilation exhaust connection
13	Product outlet connection
14	Softened water outlet connection
15	Feed water supply connection
16	Integral salt saturator

Function Description

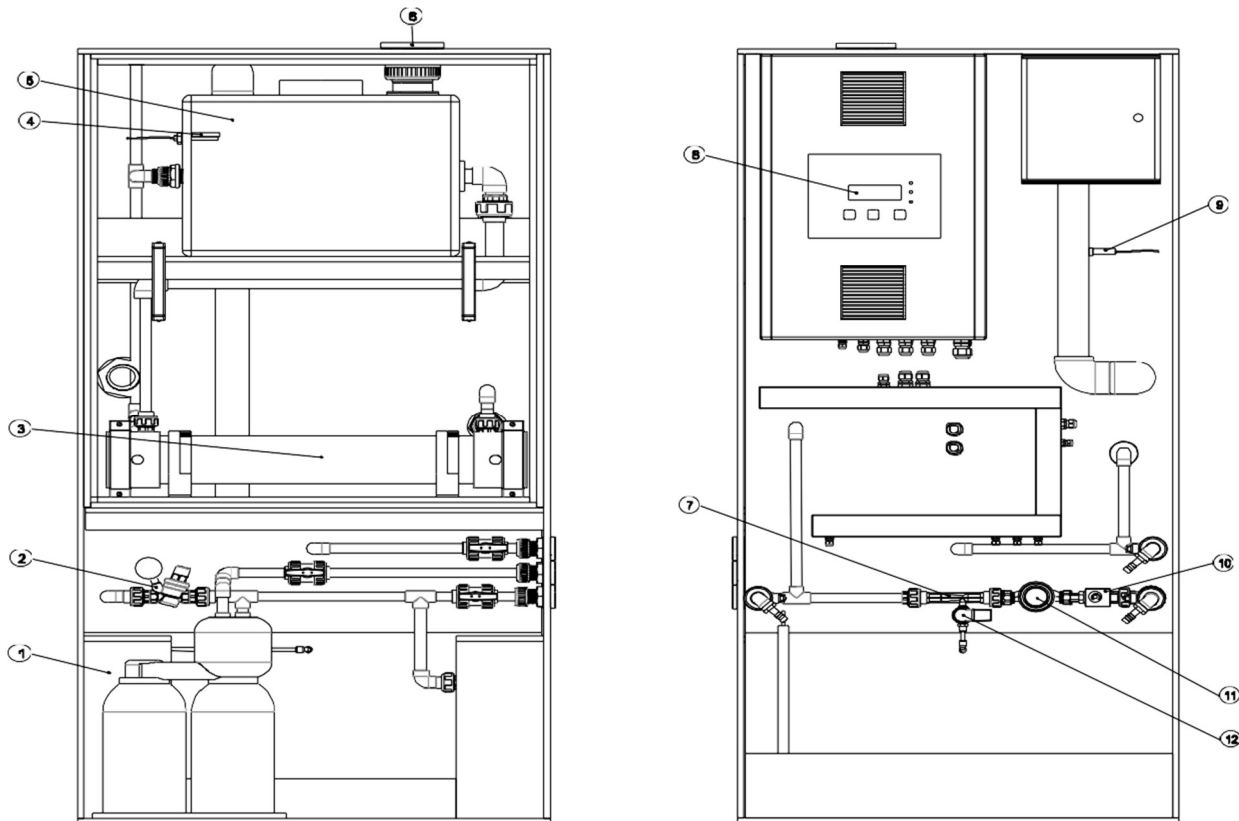

Hyprolyser® is a fully automatic system for the preparation of dilute sodium hypochlorite solution containing 0.6% (+/-0.1%) Cl₂ from the raw materials of salt, softened water and electrical energy.

Sodium hypochlorite solution (the product) is prepared by a simple, once through batch process, initiated by the level within the Product Tank.

When the product level in the degassing/product tank (5) falls below the start/stop fill level (4), after pre-set time delay, the water solenoid valve (10) is energised, which allows softened water to flow at reduced pressure through the pressure reducing valve (2) and then on through the volumetric flow meter (11). The water stream flows through the brine inductor (7) and draws in a set amount of brine from the saturator tank (1) controlled by the brine control solenoid valve (12). The resultant diluted and mixed brine solution passes through the electrolytic cell (3). At the same time, a voltage is applied across the electrolytic cell and electrical current flows across the electrolytic cell plates when the diluted brine solution completes the path between the electrode plates.

When the product reaches the start/stop fill level (4) in the product/degassing tank, the process is stopped. The process is restarted after a predetermined delay period, initiated when the liquid level in the product/degassing tank falls below the start/stop fill level (4). The process can also be re-started instantaneously from the keypad on the control panel (8).

Whilst the unit is generating sodium hypochlorite product, hydrogen gas is produced as a by-product. Hydrogen is diluted at source with a continuous flow of fresh air and is vented safely to the atmosphere via ducting (6) to an external exhaust point. The system is designed so that there are no external areas where hydrogen levels can exceed the LEL (lower explosive limit). An air-flow sensor (9) is fitted to shut down the plant if the electrolyser cabinet is opened, or should the ventilating air flow fail to achieve normal operating parameters.

If a fault occurs during operation, the Hyprolyser system will fail safe. A text display on the control panel (8) will advise of the reason for the fault and initiate a volt free contact which can be used for a remote alarm device.

Technical Data

Output Data

Model:				560	1100	2200
Chlorine capacity	g/h			560	1100	2200
Chlorine concentration	g/l	Factory set at 6 (adj. from 5 to 8)				
Liquid product output	l/h			92	183	366
Liquid product storage*	L	50*				
Salt storage capacity	kg	250**				

* refers to Hyprolyser® system with integrated product degassing tank.

** refers to Hyprolyser® system with integrated salt saturator.

Operating Conditions and Limits

Model:				560	1100	2200
Nominal water consumption	l/h			98	196	392
Nominal salt consumption	kg/h			1.8	3.6	7.3
Operating pressure	Bar	1.5 – 8.5				
Ambient temp	°C	+5 to + 40†				
Water supply temp	°C	+8 to +20*				

† Request ventilation upgrade kit.

* Water chiller required above 20°C.

Electrical Specifications

Model:				560	1100	2200	
Nominal power supply	V ac	240*			240	415	415
Phase	Ø	1			1	3	3
Power consumption	kWh			2.8	5.6	11	
Protection class	IP	IP44					

*Available 110Vac special order request

Connection Dimensions

Description	Model:		560	1100	2200
Cold water feed					
Product outlet			0.5" / 20mm		
Softened water outlet					
Saturated brine inlet*			¾" BSPm		
Softener backwash waste outlet			12mmOD		
Hydrogen vent line			2" / 63mm		
Electrical connection point			M20		M25
Control panel cable terminations			2.5 – 4mm ²		2.5 - 6mm ²

* supplied with external salt saturator option

Components Coming Into Contact with the Media

Description [all models]	Material
Electrolytic cell	PVC, titanium, PTFE, FPM
Product transfer pipe	PVC
Product tank	MDPE
Product tank level switch assembly	PVDF/PVC, FPM/PPS

Other Data

Model:				560	1100	2200
Net weight	kg			102	108	116

	Swimming pool
Free available chlorine	1.0 - 3.0 ppm
pH	7.2 - 7.8
Total alkalinity	100 - 120 ppm
Calcium hardness	200 - 300 ppm

External Product Tank Storage Facility Option

Description	Capacity (litres):		500	1000	2000
Inlet/outlet connection			1" / 32mm uPVC soc.		1.5" / 50mm uPVC soc.
Level switch electrical connection			2 x 2m, 2 core pvc flexible cable assembly (4 x 0.75mm ²)		
Lid aperture			200		370
Net weight			26	37	75

External Salt Saturator Option

Description	Capacity (kg):	500	1000
Softened water feed connection		1/2" BSPm	
Saturated brine outlet connection		3/4" / 25mm	
Net weight		26	37

Installation

Installation Location

Hyprolyser® System

Precondition for action:

- ✓ A firm and level floor is required for the skid mounted system.
- ✓ The plant room has high level natural ventilation.
- ✓ The system must be accessible for operation, day-to-day filling with salt and for maintenance.
- ✓ Refer to all installation procedures.

Perform the following steps:

1. Place the skid unit into its intended permanent position allowing sufficient space to connect services to the connection ports to the side and top of the system.
2. Install the hydrogen gas detector above the location of the Hyprolyser® System, preferably up against the underside of the room ceiling or at the highest point in the immediate room. The sensor head unit is supplied with a fixing bracket that must be used in order to facilitate quick and easy replacement of the sensor head at the time of future maintenance/replacement.

- ✓ **Location of skid system complete**

External Product Tank Facility Option

Precondition for action:

- ✓ A firm and level floor is required for the external product tank facility.
- ✓ The system must be accessible for operation, day-to-day filling with salt and for regular/routine maintenance procedures.
- ✓ The external product tank must be on the same floor level as the Hyprolyser® to ensure correct operational control of liquid product level.

Perform the following steps:

1. Place the product tank into position preferably near/adjacent to the Hyprolyser®.
2. Align the tank so that the tank capacity graduation markers will be visible in operation.

- ✓ **Location of external product tank complete**

External Salt Saturator Option

Precondition for action:

- ✓ A firm and level floor is required for the external product tank facility.

- ✓ The system must be accessible for operation, day-to-day filling with salt and for regular/routine maintenance procedures.
- ✓ Refer to all installation procedures.

Perform the following steps:

1. Locate the product tank into position preferably near/adjacent to the Hyprolyser®.
2. Align the tank so that inlet & outlet pipe connections are conveniently situated for connection to appropriate services.

✓ **Location of external product tank complete**

Cold Water Supply

Precondition for action:

- ✓ A minimum cold water supply pressure of 1.5 bar is required.
- ✓ The equipment must be supplied with clean water of a quality similar to drinking water. Waters which are high in magnesium content may reduce the life of the system water softener resin.
- ✓ A verifiable double check valve or pipe disconnecter in the drinking water supply is fitted upstream of the entire Hyprolyser® System and any ancillary softener equipment if the local conditions require it.
- ✓ A pressure reducing valve should be fitted to the water supply if the supply pressure is greater than 8.5 bar.

Perform the following steps:-

1. Connect a ½" (20mm) uPVC solvent cement cold water pipe supply to the Hyprolyser® connection point. Ensure an isolation valve is fitted upstream to enable safe isolation during future maintenance.

Integral Softener Backwash Waste Line

The Hyprolyser® water softener produces back-wash waste water during regeneration and this must be directed to a suitable waste drain.

Precondition for action:

- ✓ A local waste water drain is available at floor level and within 10m of the Hyprolyser®.

Perform the following steps:

1. Install and fit a 12mmOD flexible drain pipe to the outlet connection of the Hyprolyser® integral softener unit.
2. Connect the 12mmOD tubing to the drain leaving a break in the discharge. The waste line should not rise higher than 2.4m above the water softener outlet and no further than 9m horizontally.

✓ **Softener backwash plumbing complete**

External Salt Saturator Option

If an external salt saturator has been supplied within the scope of the system, the saturator requires a softened water supply.

Precondition for action:

✓ Hyprolyser® and external salt saturator located correctly.

Perform the following action:

1. Interconnect the ½" (20mm) softened water outlet of the Hyprolyser® to the ½"BSPm side inlet connection of the salt saturator tank.
2. Fit the ½" plastic float valve (supplied as part of the saturator fitting kit) to the brine inlet port located on the side wall of the Hyprolyser® integral salt saturator.
3. Connect the saturator's brine outlet to the Hyprolyser® brine inlet float valve (previously fitted) using minimum ¾" (25mm) rigid plastic pipe work. Install a plastic isolating ball valve inline to provide safe isolation during future maintenance.

✓ **External saturator plumbing complete**

External Product Tank Option

If an external product tank facility has been supplied within the scope of the system, this will require connection to the Hyprolyser®.

It is intended that the dosing outputs from the tank are taken via a manifold connected to the product tank inlet/outlet with a suitable plastic chemical resistant isolating ball valve for each dosing output.

For further guidance, refer to the installation instructions provided with the external product tank facility unit.

Precondition for action:

- ✓ Hyprolyser® and external salt saturator located correctly.
- ✓ Refer to installation procedures.

Perform the following steps:

1. Install a suitable isolating ball valve to the inlet/outlet of the product tank.
2. Install a suitable dosing output manifold to the tank isolating ball valve.
3. Connect the dosing manifold to the Hyprolyser® product outlet connection point, preferably installing an isolating ball valve between the Hyprolyser® and the dosing manifold.

✓ **Product tank plumbing complete**

Hydrogen Ventilation

The HYPROLYSER® requires the installation of a ventilation pipe duct circuit between the unit and to a suitable exterior outside termination vent point (normally at high level >3m), in order to safely vent any hydrogen gas liberated from the electrolytic process.

The exterior vent pipe termination point must be installed so as to create a Zone area around the opening of the vent. Refer below to "External Zone 2 Requirement" for guidance.

Plan the pipe route as direct and straight as possible and always on an incline from the vent discharge connection on the skid to a discharge point within 15 metres.

If a vent pipe route >15m is unavoidable, then the duct pipe diameter must be increased to 3" (90m) nominal diameter along its entire length.

Use wide radius bends instead of elbows to reduce air friction. DO NOT install any unions or any disconnection points at any point along the vent pipe work.

To comply with Health & Safety requirements, the vent termination point on the external wall should not be located directly beneath any air intake and must be located at least 0.8m from any window or possible source of ignition. If the external vent pipe work is located in a public area, or there is a possibility of vandalism, it should be protected with a suitable steel cage/pipe capping.

It is advisable to provide the following warning signs in the plant room and exterior vent point:

- Warning Sign
- No Smoking
- No Naked Flames

Precondition for action:

- ✓ Suitable outside vent point provided
- ✓ Adequate natural air room ventilation

Perform the following steps:

1. For ventilation duct length less than 15m, install 2" (63mm) ventilation piping from the socket connection located on top of the HYPROLYSER® cabinet to the exterior vent point provided.
2. For ventilation duct length greater than 15m, install 3"(90mm) ventilation piping from the socket connection located on top of the HYPROLYSER® cabinet to the exterior vent point provided.
3. Provide and fix appropriate signage at the vent point in accordance with local rules.

✓ **Standard ventilation installation complete.**

External Zone 2 Requirement

The following External Zone 2 requirements are necessary at the point of the external vent as indicated.

System type	External vent Zone 2 radius
Hyprolyser 560	1.3 m
Hyprolyser 1100	1.9 m
Hyprolyser 2200	2.8 m

If in doubt, contact your supplier for further advice.

Electrical Installation

Precondition for action:

- ✓ Unit located correctly
- ✓ Identify system model/type

Perform the following working steps:

1. Wire in accordance with the wiring diagrams.
2. Connect the main electrical power supply to the control panel, via the connection point provided on the underside of the control panel.
3. Ground the device in accordance with local regulations.
4. Interconnect the M12 cable assembly to the Hyprolyser® control panel and the hydrogen gas detector. An M20 connection point on the underside of the control panel is provided for this cable route.
5. If an external product tank facility has been supplied within the scope of the system, connect the external tank level switch cable assembly to the Hyprolyser® control panel. An M20 connection point on the underside of the control panel is provided for this cable route.
6. Interconnect any auxiliary wiring (for devices supplied outside the scope of the standard system) using the spare cable glands provided.

✓ **Control panel wiring complete**

Start Up

Turning on the System

Precondition for action:

- ✓ The system is configured according to the factory setup.
- ✓ The system has been installed in accordance with the Installation.
- ✓ The control device is grounded.

Perform the following working steps:

1. Set the main rotary isolator switch to ON
 2. Start-up screen appears
 3. System will perform a set number of water and brine batch cycles to initially charge the electrolytic cell with a minimum volume of brine solution prior to automatically starting normal generation/batch cycles.
- ✓ **Device switched ON**

Commissioning the System

Precondition for action:

- ✓ Hyprolyser® trained commissioning technician.
- ✓ Water supply connected.
- ✓ Wiring completed.
- ✓ The salt saturator is filled with a pre-charge of the correct specification of granular salt.
- ✓ The hydrogen gas sensor detection kit is correctly installed and electrically connected via the 4-pin plug/M12 cable assembly as per installation instruction.

Perform the following working steps:

1. Start-up the Hyprolyser®.
2. Check clock settings by pressing and holding the scroll UP key, while in System Healthy display screen, for 5 seconds. The following MANUAL INHIBIT screen will appear and stop the system.
3. Press the ENTER button for 5 seconds to access the Service Menu.
4. Using the UP/DOWN scroll keys, enter the service code 2236. Each digit needs to be individually selected and entered.
5. Scroll UP until Program 6 is revealed.
6. Press ENTER and then scroll DOWN to adjust date and time accordingly. Pressing ENTER at the EXIT screen will revert to Service Menu.

7. Scroll UP until Program 1 / End Program Mode is reached. At this point press ENTER and the display will return to the MANUAL INHIBIT screen.
8. To restart the system press and hold the scroll UP key for 5 seconds.
9. System will now resume its previous automatic status.
10. When the SYSTEM HEALTHY screen is visible, scroll DOWN to observe engineer display 1.

The normal DC Volt reading should normally be in the range of between 25 and 28 volts.

- * The DC volt reading may take several hours to stabilize on initial commissioning owing to the water/brine solution strength stabilizing.
11. Continue to scroll DOWN to observe Eng. Display 4, which provides a visual indication of the hydrogen threshold as a percentage. An acceptable level of <50% should always be the case. The hydrogen gas detect system is factory set and requires only an annual service inspection/test.
 12. After 12 to 24 hours of operation it is recommended to perform a chlorine product strength test. The result should ideally be 0.6% +/- 0.1% ¹.
 13. Complete a Commissioning record log.
- ✓ **System commissioning completed.**

¹ The chlorine strength is factory pre-set to 0.6% +/-0.1%. The chlorine solution strength may be adjusted within the range of 0.5% and 0.8% by altering the control program logic. Please consult your main dealer or manufacturer for guidance.

Operation

Automatic Operation

The on-site electrolytic chlorine generation and preparation Hyprolyser® System is automated. The softened water supply is automatically regulated according to the system demand. The salt saturator should be refilled with salt manually before allowing it to become empty. Avoid allowing the level to drop <25%.

The system process will START and STOP according to the level of the product storage tank facility.

When the tank is full, the display will show: SYSTEM STOPPED - TANK FULL

When the system is generating and the tank is filling, the display will show: SYSTEM HEALTHY - GENERATING

Manual Inhibit

The automatic process may be interrupted by placing the control cycle in to MANUAL INHIBIT mode. This will STOP the automatic electrolytic process.

While the system is displaying SYSTEM STOPPED or SYSTEM HEALTHY, the scroll UP key may be pressed for 5 seconds to place the system into MANUAL INHIBIT mode which halts the system:

Press the scroll UP key again for 5 seconds to resume automatic operation.

Remote Inhibit

The Hyprolyser® may be connected to an external switch intended to stop the system remotely. If the system is stopped remotely, the screen will display REMOTE INHIBIT. The system will not resume automatic operation until the remote inhibit function is released.

Softener Regeneration

Failure to provide a softened feed water supply for the normal operation of the system will most likely result in failure of the system and affect the warranty conditions.

The regenerative duplex water softener fitted within the Hyprolyser® automatically regenerates based on water volume consumed through the electrolytic/tank filling process. There is no requirement for operator intervention apart from taking regular weekly water tests to verify the water exiting the softener system is indeed softened. Use the “softened water sample valve” to carry out the soft water test.

Emergency Shutdown

In the event of an emergency, immediately disconnect the device from the main electrical supply. This can be achieved by switching the rotary isolator to the off position.

If an auxiliary Emergency Stop device has been connected to the device, this can be activated to stop the system. If this is the case, the Hyprolyser® System will need to be reset on the panel by pressing the ENTER button, once the Emergency Stop device has been released.

Record Log of Operation

In order to maintain and monitor the performance of the system and ensure the system is operated within manufacturer warranty conditions, the operator has the responsibility to complete an Operator Log.

✓ **Warranty compliance**

Maintenance and Cleaning

The Hypolyser® Units are manufactured to the highest quality standards and have along service life. However, some parts are subject to operational wear. This means that regular visual inspections are necessary to ensure a long service life. Regular maintenance will protect the system from operational interruptions.

Maintenance Intervals

The system requires regular maintenance to prevent errors, poor performance and even failure. This table gives an overview of maintenance work and the intervals at which you must carry it out. The next few sections contain instructions for carrying out this work.

Interval	Level	Maintenance
Annual	Technician	<ul style="list-style-type: none"> ■ Clean brine venturi manifold ■ Clean brine solenoid valve ■ Check water solenoid valve integrity ■ Check & Test hydrogen gas sensor
2 yrs. (or >10,000 operating hours)	Technician	<ul style="list-style-type: none"> ■ In addition to above: ■ Replace pipe seals/gaskets ■ Replace brine solenoid valve seat ■ Replace degassing tank level switch
5 yrs.	Technician	<ul style="list-style-type: none"> ■ Major service

Clean Brine Venturi Assembly

The brine venturi assembly may occasionally be compromised due to sediment fouling carried in via the water supply. One of the reasons the Hypolyser® may alarm on "VOLTAGE HIGH" is due to a restricted flow of water through the venturi resulting in a decreased vacuum/suction of brine through the venturi device.

Precondition for action:

✓ Product tank below START point

Perform the following working steps:-

1. Switch off the power supply to the Hypolyser® via the rotary panel isolator and then switch back on again after 10 seconds.
2. Allow the control to run through the STARTING UP function. When the system commences to go into normal operation "SYSTEM HEALTHY/ GENERATING", immediately switch off the power supply again to isolate the system.
3. Drain down the brine solution from the electrolyser feed pipe work by opening the salinity sample point and discharging into a clean bucket. Wait until drip free and then close the sample valve.
4. Remove the venturi from the pipe circuit by unscrewing the inlet/outlet connections and the brine suction.
5. Carefully inspect the internals of the venturi device and wash in warm soapy water. DO NOT attempt to use any sharp objects to scour/clean internal surfaces.
6. Replace the venturi in reverse procedure to above taking care to ensure all O-rings are correctly in place.
7. Now carry out the brine valve clean/inspection described below.

✓ **The venturi assembly has been successfully checked.**

Cleaning/Serviceing the Brine Control Solenoid Valve

The brine control solenoid valve may eventually wear and allow an excessive volume of brine to pass through its body when functioning or even when in stand-by operation during the water batching/filling process.

Precondition for action:

- ✓ Venturi cleaning, completed.

Perform the following working steps:

1. Unscrew the brine control solenoid valve main body black plastic locking nut to remove the front half of the valve from its base. Gently clean the round black rubber seat. If the black rubber seat appears worn/damaged, replace using the correct service kit. The diaphragm should be replaced every 2 years as a preventative maintenance action.
2. Start-up the system.

- ✓ **The brine control solenoid valve has been successfully cleaned/serviced.**

Checking/Cleaning the Water Control Solenoid Valve

The water control solenoid valve may eventually wear or become fouled with fine debris and allow a small flow of water to pass through its body when in stand-by operation during the water batching/filling process.

Precondition for action:

- ✓ Product tank below START point

Perform the following working steps:

1. Switch off the power supply to the Hypolyser® via the rotary panel isolator and then switch back on again after 10 seconds.
2. Allow the control to run through the STARTING UP function. When the system commences into normal operation "SYSTEM HEALTHY/ GENERATING", immediately switch off the power supply again to isolate the system.
3. Drain down the brine solution from the electrolyser feed pipe work by opening the SG salinity sample point and discharging into a clean bucket. Wait until drip free and then close the sample valve.
4. The venturi assembly now needs to be carefully removed from its position by unscrewing the two PVC union nuts. Lower the venturi assembly so that the pipe orifice on the discharge of the water solenoid valve can be clearly seen.
5. Switch on the water supply to the system. Observe the open orifice. No water should pass through the water solenoid. If water is slightly passing, isolate the water supply. The brass water solenoid requires removing in order to clean the internal body section or alternatively replace with a new solenoid valve if found to be damaged.
6. Having checked/cleaned/replaced the water solenoid, re-install taking note of correct flow direction (right to left).
7. Ensure the venturi/brine control assembly is carefully refitted and secure.
8. Start-up the system.

- ✓ **The water control solenoid valve has been successfully cleaned/serviced.**

Hydrogen Gas Detector Inspection

The hydrogen gas (H₂) detection system is very important to ensure a safe environment. The H₂ detector should be routinely tested annually in order to verify a safe system of work. The H₂ level detected in the immediate atmosphere is displayed on the screen and should normally be below 50%. This reading can be displayed by scrolling DOWN at the Hyprolyser® panel to reveal Eng. Display 4:

Precondition for action:

- ✓ Hyprolyser® System in normal automatic operation.

Perform the following working steps:

1. Prepare the Hyprolyser® H₂ test device (available separately) as per device instructions.
2. Position the tester device so that it liberates its test gas directly at the sensor head as per the device instructions.
3. The reading on the display will quickly rise to 100% at which point will trigger the hydrogen sensor fault.
4. Remove the H₂ test device from the sensor and the reading will quickly return to a low reading below 50%. If the Sensor does not react or read 100% during the test, then the sensor must be replaced.

* When the display reads 100%, this is equivalent to a H₂ detection level in the atmosphere of less than 25% of the LEL threshold.

- ✓ **The hydrogen gas detection system has been successfully checked/sensor replaced.**

Replace Pipe Seals/Gaskets

Elastomers (rubber seals) exposed to the electrolytic process are subject to chemical wear and require routine replacement every two years regardless of operating hours as a preventative maintenance action.

Prior to commencing this maintenance action, the electrolytic hydraulic circuit requires purging of residual chlorine solution.

Precondition for action:

- ✓ Perform Short-term shut down procedure.
- ✓ Bi-annual service kit available.
- Check for seal replacement.

Perform the following working steps:

1. Drain down the product/degassing tank and associated pipe work by closing the external product tank inlet valve (or product isolation valve located immediately downstream of the Hyprolyser® unit) and opening the product sample point Valve. Allow the solution to drain into a clean plastic bucket. Empty contents carefully into the external product tank or carefully wash away to a waste sewer drain with copious water. Close the product sample valve when drip free.
2. Drain the brine/product solution pipe work by opening the brine salinity sample point valve. Allow the contents to empty into a clean plastic bucket until the sample point is drip free. Close the brine salinity sample point valve.

3. Remove the electrolyser cell enclosure window by removing the vertical window bead retainers and then the horizontal window bead retainers.
4. Commence replacing elastomers located at key 1 to 7.
5. Carefully loosen each fitting, in-turn replacing gaskets/O-rings with correct replacements. Refit connections hand-tight only.
6. Ensure the electrolyser chamber window is refitted correctly back into position.
7. Ensure the water supply is turned on to the system.
8. Perform start-up.

✓ **Elastomer replacement successfully carried out.**

Replace Product/Degassing Tank Level Control Switch

The product/degassing tank level control switch requires routine replacement every 2 years, regardless of operating hours. This is a preventative maintenance action to ensure safe operation of the system.

Precondition for action:

- ✓ Perform Short-term shut down procedure.
- ✓ Bi-annual service kit available.
- ✓ Product/degassing tank solution level is at the "safe height" of at least 20mm below the level switch assembly.

Perform the following working steps:

1. If the product/degassing tank level are at the tank full height then one of the following actions is required:
 - allow the product/degassing tank to empty to at least the safe height, or
 - close the product outlet valve situated in the salt saturator compartment and then drain off the product in the pipe work by opening the product sample point valve.

Allow the solution to drain into a clean plastic bucket. Empty contents carefully into the external product tank or carefully wash away to a waste sewer drain with copious water. Close the product sample valve when drip free.
9. Remove the existing level switch by firstly unscrewing the in-line M12 signal cable connection assembly. Then loosen the level switch's external black locking nut until the switch can be fully withdrawn from the tank.
10. Fit the new level switch assembly ensuring the correct alignment of the pivot float device. The float should be facing vertically upward as per product image below.

Product/degassing tank level control switch



11. Tighten re the level switch is fitted correctly. DO NOT over-tighten plastic fittings!

12. Reconnect the in-line M12 signal cable connection assembly to the new switch connector plug.

13. Ensure the water supply is turned on to the system.
 14. Perform start-up.
- ✓ **Product/degassing tank level control switch replacement successfully carried out.**

Major Service

A major overhaul of the Hyprolyser® System is required every 5 years, regardless of operating hours. An approved Hyprolyser® service technician will be required to conduct this maintenance regime.

Control devices, the electrolytic cell, the salt saturator and all associated pipe work will require thorough inspection and cleaning and worn/defective parts replaced as necessary.

The water and brine control solenoid valves will require replacement.

The electrolytic cell will require an acid clean and its two cell casing end cap gaskets replacing and the two terminal O-rings replacing.

All standard pipe connection elastomers will require replacement.

The hydrogen gas detect sensor head will require replacement.

If an auto regenerative softener is fitted, the softener will require a full service of its valve head assembly and the internal softener resin replacing.

All safety switches and safety devices to be fully tested.

Action to be taken:

- c:> **Contact your Hyprolyser® service provider to arrange a major overhaul service.**
- ✓ **General overhaul will provide for future safe operation and continued routine service.**

Electrolyser Cleaning

The electrolyser (electrolytic cell) may require acid cleaning periodically to remove the presence of water hardness scaling and also any heavy metal deposition e.g. iron and manganese deposits.

Precondition for action:

- ✓ Perform Short-term shut down procedure.

Perform the following working steps:

1. Drain down the product/degassing tank and associated pipe work by closing the external product tank inlet valve (or product isolation valve located immediately downstream of the Hyprolyser® unit) and opening the product sample point valve. Allow

the solution to drain into a clean plastic Bucket. Empty contents carefully into the external product tank or carefully wash away to a waste sewer drain with copious water. Close the product sample valve when drip free.

2. Drain the brine/product solution pipe work by opening the brine salinity sample point valve. Allow the contents to empty into a clean plastic bucket until the sample point is drip free. Close the brine salinity sample point valve.
3. Remove the electrolyser cell enclosure window by removing the vertical window bead retainers and then the horizontal window bead retainers.
4. Loosen the cell connection fittings (key no.5) until the cell can be carefully rotated 30 degrees outward facing.
5. Connect the acid wash cleaning system to the electrolyser in accordance with the operating instructions provided with the Hyprolyser® acid washing kit.
6. Completely rinse/flush out the electrolyser with clean water prior to repositioning and connecting up the electrolyser chamber once again to the pipe work. Screw plastic cell pipe work locking collars until hand-tight.
7. Ensure the electrolyser chamber window is refitted correctly back into position.
8. Ensure the water supply is turned on to the system.
9. Perform start-up.

✓ **Electrolyser acid wash carried out successfully.**

Finishing Maintenance

Perform the following working steps:

1. Make a note of the date and scope of the maintenance performed.
2. Complete any operational, service or commissioning log sheets associated with the Hyprolyser® System and as per any associated documents.
3. Attach a sticker displaying the maintenance date to the system.
4. To assure correct start up procedures, refer to section "Start-up".

✓ **Maintenance completed.**