

2019-5907  
2019-11-29

**Lectranator Systems Inc.  
1034 - 72 Avenue N.E.  
Calgary, Alberta T2E 8V9**

**REGISTRATION NO. 25615  
PEST CONTROL PRODUCTS ACT  
CUBBY SALT WATER PURIFIER  
MODEL AC5**

**Maximum output of Sodium Hypochlorite  
equivalent to 0.22 kg of chlorine per day**

**WARNING: Operating the CUBBY  
Salt Water Purifier Model AC5 without  
water flow through the cell can cause a  
build up of flammable gases which can  
result in FIRE OR EXPLOSION**

**DOMESTIC  
READ THE LABEL AND THE  
INSTRUCTION MANUAL  
BEFORE USING**

# Salt Water Purifier

# CUBBY

By Lectranator Systems Inc.

## DOMESTIC Installation / Operation Manual

MODEL AC3 REGISTRATION NUMBER 25616 PEST CONTROL PRODUCTS ACT  
MODEL AC5 REGISTRATION NUMBER 25615 PEST CONTROL PRODUCTS ACT

**PLEASE RETAIN OWNER'S MANUAL FOR FUTURE REFERENCE**



### IMPORTANT

**READ THE LABEL AND THIS MANUAL BEFORE INSTALLING &  
OPERATING Lectranator Systems, Inc., 1034 - 72 Ave. N.E. Calgary, Ab.  
T2E 8V9**

# TABLE OF CONTENTS

## Models: AC3 & AC5

Important Safety Instructions	i,ii
Health, General & Hyperthermia	1
Specifications	2

### Section 1 Water Pretest & Preparation

1 a System Sizing	3,4
1 b Pool Water Preparation & Monitoring	5-6

### Section 2 Plumbing Requirements

2a Material Requirements for Installation	7
2b Cell Installation & Pool Diagrams	8, 9

### Section 3 Control Panel Mounting & Wiring

3a Wiring	10
3b General Information	11

### Section 4 Start Up & Operation

4a Control Panel Indicators	12,13
4b Start Up Sequence	13

### Section 5 Trouble Shooting

5a Trouble Shooting	14,15
---------------------	-------

### Appendix

Appendix - Above Ground Installation Locations	16,17,18
Appendix - Service Information	19

# **IMPORTANT SAFETY INSTRUCTIONS**

## **READ AND FOLLOW ALL INSTRUCTIONS**

### **EQUIPMENT RELATED, INSTALLATION AND GENERAL USE**

#### **Installation of all Salt Water Purifier CUBBY models**

When installing and using the CUBBY Salt Water Purifier unit, basic safety precautions must always be followed, including the following:

1. Follow all aspects of the local and National Electrical Code(s) when installing the CUBBY Salt Water Purifier unit.
2. During installation, mount the CUBBY unit to ensure the least amount of direct exposure to rain, garden sprinkler water, direct sunlight or any corrosive environment.
3. **WARNING** - Risk of electrical shock. Install at least 1.5 m (5 feet) from the inside wall of the pool or spa using non-metallic plumbing.
4. **WARNING** - Do not use spas, hot tubs or pools unless all suction grates are installed to prevent body and hair entrapment.
5. **DANGER** - To reduce the risk of drowning from hair and body entrapment, install suction fitting(s) with a marked flow rate that equals or exceeds the flow rate on the equipment assembly.
6. **WARNING** - Install blower no less than 30 cm (1 foot) above the maximum water level to prevent water from contacting electrical equipment.
7. Do not install the CUBBY unit within an outer enclosure or beneath the skirt of a hot tub or spa.
8. **CAUTION** - Maintain water chemistry in accordance with manufacturer's instructions.
9. All field-installed metal components such as rails, ladders, drains, or other similar hardware within 3 m (10 feet) of the spa or hot tub shall be bonded to the equipment grounding bus with copper conductors not smaller than No. 8 AWG in the U.S.A. and No. 6 AWG in Canada.

# **IMPORTANT SAFETY INSTRUCTIONS**

## **110V Models Only (cord and plug)**

- 1. WARNING - Risk of Electric Shock. Connect only to a grounding type receptacle protected by a ground-fault- circuit -interrupter (GFCI). Contact a qualified electrician if you cannot verify that the receptacle is protected by a GFCI. The conductors on the load side of the GFCI shall not occupy conduit boxes or enclosures containing other conductors unless the additional conductors are also protected by a GFCI.**
- 2. The GFCI must be tested before each use. With the CUBBY unit operating push the test button on the GFCI. The CUBBY unit should stop operating. Push the reset button. The CUBBY unit should now start to operate normally. If the GFCI fails to operate in this manner, there is a ground current flowing indicating the possibility of an electrical shock. Disconnect the power until the fault has been identified and corrected.**
- 3. WARNING - To reduce the risk of electric shock, replace damaged cords immediately.**
- 4. WARNING - To reduce the risk of electric shock, do not use extension cords to connect unit to electric supply; provide a properly located outlet.**
- 5. Do not bury cord. Locate cord to minimize abuse from lawn mowers, hedge trimmers and other equipment.**

## **220V Models Only (fixed wiring)**

- 1. A wire connector is provided on the CUBBY unit to connect a minimum No. 8 AWG (8.4mm) solid copper conductor between this unit and any metal equipment, metal enclosures of electrical equipment, metal water pipe, or conduit within 1.5 m (5 feet) of the unit.**
- 2. A bonding terminal is located inside the CUBBY unit. To reduce the risk of electrical shock, this terminal must be connected to the grounding means provided in the electric supply service panel with a continuous copper wire equivalent in size to the circuit conductors supplying the CUBBY.**

## **General Use**

- 1. WARNING - To reduce the risk of injury do not permit children to use this product unless they are closely supervised at all times. Children should not use spas, hot tubs or pools without permanent adult supervision.**
- 2. WARNING - Risk of Accidental Drowning. Extreme caution must be exercised to prevent unauthorized access by children. To avoid accidents, ensure that children cannot use a spa, hot tub or pool unless they are closely supervised at all times.**
- 3. DANGER - To reduce the risk of injury, do not remove the suction grates. Never operate a spa or pool if the suction grates are broken or missing. Never replace a suction grate with one rated less than the flow rate marked on the equipment assembly.**
- 4. DANGER - Risk of electrical shock. Do not permit any electrical appliance, such as a light, telephone, radio, or television, within 1.5m (5 feet) of spa or pool.**
- 5. To avoid injury exercise care when entering or exiting the spa, hot tub or pool.**

# HEALTH, GENERAL & HYPERTHERMIA

## HEALTH, GENERAL AND HYPERTHERMIA

General: WARNINGS - To reduce the risk of injury:

1. People using medications and/or having an adverse medical history should consult a physician before using a spa, hot tub or pool.
2. People with infectious diseases should not use a spa, hot tub or pool.
3. The water in the spa should never exceed 40°C (104°F). Water temperatures between 38°C (100°F) and 40°C (104°F) are considered safe for a healthy adult. Lower water temperatures are recommended for young children and when spa use exceeds 10 minutes.
4. Water temperature in excess of 38°C (100°F) may be dangerous to your health.
5. Pregnant or possibly pregnant women should consult a physician before using a spa or hot tub.
6. Since excessive water temperatures have a high potential for causing fetal damage during the 1st trimester of pregnancy, pregnant or possibly pregnant women should limit the spa water temperatures to 38°C (100°F).
7. Before entering a spa or hot tub, the user should measure the water temperature with an accurate thermometer since the tolerance of water temperature regulating devices varies.
8. The use of alcohol, drugs, or medication before or during spa or hot tub use may lead to unconsciousness with the possibility of drowning.
9. Obese persons and persons with a history of heart disease, low or high blood pressure, circulatory system problems, or diabetes should consult a physician before using a spa.
10. Persons using medication should consult a physician before using a spa or hot tub since some medication may induce drowsiness while other medication may affect heart rate, blood pressure, and circulation.
11. Do not use a spa or hot tub immediately following strenuous exercise.
12. Prolonged immersion in a spa or hot tub may be dangerous to your health.

### Hyperthermia

**WARNING** - The use of alcohol or drugs can greatly increase the risk of fatal hyperthermia in hot tubs and spas.

Consult your spa/hot tub manufacturer's manuals for the proper adjustment of water temperature. Prolonged immersion in hot water may induce hyperthermia. Hyperthermia occurs when the internal temperature of the body reaches several degrees above the normal body temperature of 37°C (98.6°F). Hyperthermia symptoms include drowsiness, lethargy, and an increase of internal body temperature.

The effects of hyperthermia include:

1. unawareness of impending hazard
2. failure to perceive heat
3. failure to perceive the need to exit the spa/hot tub
4. physical inability to exit spa
5. fetal damage in pregnant women
6. unconsciousness and danger of drowning

**SAVE THESE INSTRUCTIONS**

# Specifications

**ALL MODELS INPUT:** 105 – 125 VAC, 50/60 HZ, 1.0 Amp for Model AC3-1 or AC5-1  
210 – 250 VAC, 50/60 HZ, 0.5 Amps for Model AC3-2 or AC5-2

## Outputs

**Model AC3 Cell** Maximum output of Sodium Hypochlorite equivalent to 0.11 kg. of chlorine @3.0 Amps per 24 hours @max. dial setting of 100%

**Model AC5 Cell** Maximum output of Sodium Hypochlorite equivalent to 0.22 kg. of chlorine @3.0 Amps per 24 hours @max. dial setting of 100%

**Flow Rate** Minimum: 57 Litres per minute.  
Maximum: 189 Litres per minute. (USE EXTERNAL BYPASS IF FLOW RATE EXCEEDS 189 L.P.M.)

## Automatic Self Cleaning Feature

Reverse Polarity Function ( Standard in all models)

The Reverse Polarity Function is designed to automatically clean the cell blades, maximizing the cell's ability to manufacture chlorine or bromine.

This feature is only enabled when the GREEN OK indicator is flashing. Since the OUTPUT CONTROL DIAL affects the amount of time the GREEN OK indicator is flashing, it also has the same effect with regards to the Reverse Polarity Function. See table below.

OUTPUT DIAL	TIME
0	DOES NOT REVERSE
25%	<i>Every</i> 15 hrs.
50%	<i>Every</i> 12 hrs.
75%	<i>Every</i> 9 hrs.
100%	<i>Every</i> 6 hrs.

## System Sizing

Use these three formulas to calculate the volume of water in the pool/spa:

Rectangular Pool: Length(M) x Width(M) x Average Depth(M) x1000 = Total Litres

Oval / Round Pool: Diameter (M) x Diameter (M) x Average Depth (M) x 790 = Total Litres

Free Form Pool: Average Length (M) x Average Width (M) x Average Depth (M) x 1000 = Total Litres

CUBBY System Production Capacity

---

## IMPORTANT CONCEPTS

### 1 . Purifier Demand / Pool Requirements

The rate at which purifier is consumed in any swimming pool depends on the relationship of eight major variables. Since these variables can vary widely from pool to pool and season to season, precise prediction of the purifier demand for any one pool is difficult. At the end of this section, rules of thumb are provided for CUBBY System Sizing.

#### THE VARIABLES ARE:

1. Volume and surface area of the pool /spa being purified.
2. Average water temperature maintained: As the temperature of the water increases, the purifier demand will also increase. As the temperature of the water decreases, the purifier demand will also decrease. When this happens, the output dial should be decreased to compensate for this lower demand (which will also protect your equipment from excessive levels of purifiers).
3. Cyanuric acid level maintained: This chemical, when added to pool water, significantly inhibits purifier depletion from exposure to sunlight. Cyanuric acid also inhibits corrosion if your pool is equipped with any metal components. Minimum levels or better must be maintained to ensure that the purifier being produced is protected from UV breakdown.
4. Bather load: As the bather load increases, the purifier demand will also increase.
5. Amount of direct sunlight / UV exposure: Pools exposed to larger amounts of direct sunlight are more vulnerable to increased purifier loss and algae growth. Indoor or screened pools have less purifier demand.
6. Exposure to vegetation and airborne debris: Dense landscaping near the pool, along with increased nitrate levels (urine, bird droppings, fertilizer, well water, etc.) greatly contribute to increased purifier demand.
7. Chemical dilution: Virtually all pool chemicals experience dilution through rainfall and the adding of fresh make- up water (due to evaporation, splash -out, filter backwashing, leaks, etc.). When freshwater is added, purifier demand increases for a brief period.
8. Main filter pump runtime and your pool's circulation patterns: Purifier can only be produced while the main filter pump is operating. Waterfalls/Fountains and other water features operated by the filter pump can directly effect purifier demand. The main filter pump runtime and/or output dial may need to be increased to satisfy this higher demand.



## 2. Purifier Production/ System Sizing/ "Rules of Thumb"

While purifier *demand* varies beyond precise prediction, and you may desire a higher or lower purifier residual in your pool, the following "rules of thumb" will assist you in properly selecting the correct CUBBY Salt Water Purifier model.

1. A Control Panel with a CUBBY Salt Water Purifier Model AC3 cell , operated at maximum output (3.0 Amps), at 3000 ppm salt residual will produce Sodium Hypochlorite equivalent to 0.11 kg of chlorine in 24 hours of continuous operation.

This amount of chlorine could satisfy up to 37,000 L of pool water, depending on the demand variables for purifier.

2. A Control Panel with a CUBBY Salt Water Purifier Model AC5 cell , operated at maximum output (3.0 Amps), at 3000 ppm salt residual will produce Sodium Hypochlorite equivalent to 0.22 kg of chlorine in 24 hours of continuous operation.

This amount of chlorine could satisfy up to 57,000 L of pool water, depending on the demand variables for purifier.

**NOTE:** Residual salt levels must be maintained above 2800 ppm and below 3200 ppm. Do not exceed 3200 ppm salt residual if you object to salty tasting water!

## Normal System Sizing Guide

The sizing criteria below reflects "*normal*" conditions based on field experience and proper operation. Purifying "demand" varies from one pool to another.

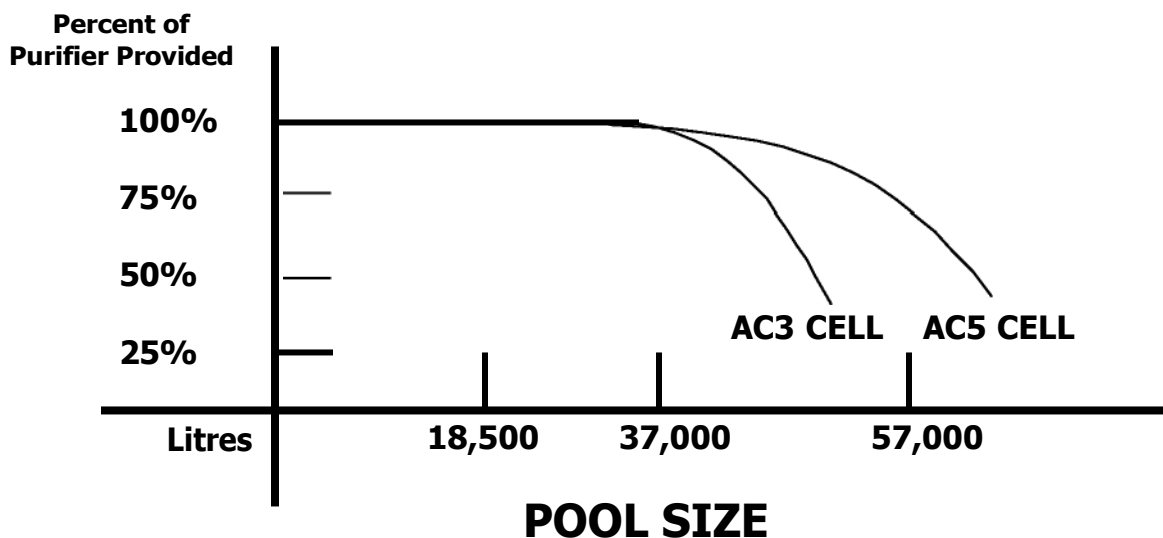

Assumes "Normal" Demand @ 10 Hours Per Day Operation

## STEP 1 - Proper Water Balance Requirements:

Proper CUBBY System operation is dependent on proper pool water conditions. Manually balance the pool water chemistry to meet all suggested ranges of water balance factors listed below before start-up of the CUBBY unit. From that point forward your CUBBY System will assist you in keeping your water chemistry factors in balance. **BEFORE START UP, MAKE SURE THE POOL WATER MEETS THE FOLLOWING REQUIREMENTS: ALL WATER BALANCE FACTORS SHOULD BALANCE WITH LANGELEIER'S SATURATION INDEX. WE RECOMMEND A VISIT TO YOUR LOCAL POOL PROFESSIONAL.**

## CUBBY System Required Ranges (And periods for testing water for these water balance factors.)

### STEP 2 - Bi-Weekly Checks

- |                                  |                  |   |
|----------------------------------|------------------|---|
| 1) Free Available Chlorine = 1.0 | - 3.0 ppm (pool) | 3) Calcium Hardness 200 - 300 ppm               |
| Free Available Bromine = 2.0     | - 4.0 ppm (pool) | 4) Total Alkalinity 100 - 200 ppm               |
| Free Available Chlorine = 3.0    | - 5.0 ppm (spa)  | 5) Cyanuric Acid 60 -80 ppm (Outdoor)           |
| Free Available Bromine = 3.0     | - 5.0 ppm (spa)  | 6) Salt Residual 2800 -3200 ppm                 |
|                                  |                  | 7) Langelier's Index (water balance) + or - 0.3 |

2) pH 7.2 -7.8

**STEP 3 - Monthly Checks:** CAUTION: Excessive Free Available Chlorine(>3.0 ppm) or Free Available Bromine (> 4.0 ppm) causes corrosion of any metal components in contact with pool/spa water. Staining and premature failure of heaters, filters, and other metal components will be the result. Do not exceed recommended purifier ranges. NOTE: Standard (DPD) pool water test kits do not read chlorine/bromine levels above approximately 8.0 ppm. Test reagents, at high levels, return to a clear liquid. **AVOID HIGH PURIFIER LEVELS!**

**STEP 4 - Salt Requirements:** It is important that a suggested salt level of 3000 ppm be maintained at all times. Allowing less than 2800 ppm salt will activate a double flashing red CHECK SYSTEM light and stop purifier generation. The amount of salt required depends on the size of the pool. Use the chart on the next page to determine the amount of salt to add, in pounds or kilograms, for a new pool start up. Also test your make up water for its level of salt and compare it with the charts on the next page. Before adding salt to a pool for the first time, turn your CUBBY unit OFF, open your main drain, then pour salt around the perimeter of the pool.

**NOTE:** Homeowners with water softening/treatment equipment, which utilize salt, may already have substantial levels of salt in their drinking water. So before adding this water to your pool, test the level of salt, then determine the amount of salt still needed to be added to bring the level up to the suggested 3000 ppm start-up level.

**NOTE:** Before adding any make-up water to your pool, it is suggested that pretesting the make-up water for high pH, total alkalinity and calcium hardness will aid in the adjustment of these levels before they become excessive.

### Manual Cleaning Of Cells

In normal conditions the CUBBY unit should not require Manual Cleaning. If manual cleaning is required, check water chemistry for possible imbalances or call the factory for consultation, and use the following procedure:

**STEP 1** - Remove the cell by loosening the unions to release.

**STEP 2** - Fill a bucket with 1 part muriatic acid added to 4 parts of water. **PUT WATER IN BUCKET FIRST!**

CAUTION: Always add acid to WATER, never water to acid.

**STEP 3** - Submerge the cell, **NOT THE FLOW SWITCH!**

**STEP 4** - After 10 - 15 minutes of foaming, remove the cell. Rinse out with fresh water.

**STEP 5** - If cell blades still have white crusty scale deposits on them, repeat the process, not to exceed 15 minute intervals.

**NOTE:** DO NOT try to remove any scale from cell blades with any tools. This may scratch or damage the coating on the blades and will VOID WARRANTY.

**KILOGRAMS OF SALT NEEDED FOR 3000 PPM RESIDUAL**

Salt Level Before Addition	Pool / Spa Volume in 1000's of Litres									
	1	2	3.5	7	15	30	35	43	50	57
0 ppm	2.5	5	10	21	42	85	106	127	148	170
320 ppm	2.2	4.5	9	18	38	76	94	113	132	152
640 ppm	2	4	8	16	33	67	83	100	116	134
960 ppm	1.5	3	7	14	28	58	72	86	101	116
1280 ppm	1.3	2.7	6	12	24	48	60	72	85	97
1600 ppm	1.1	2.2	4.5	9	19	39	49	59	69	79
1920 ppm	0.9	1.8	3.6	7	15	30	38	45	53	61
2240 ppm	0.4	0.9	2.2	5	10	21	26	32	37	43
2560 ppm	0.3	0.6	1.3	2.7	6	12	15	18	21	25
2880 ppm	0.08	0.1	0.3	0.6	1	3	4	4.5	5	7

## Section 1 b

## Cyanuric Acid Needed for 75 PPM

### Cyanuric Acid / Stabilizer/Conditioner

Cyanuric acid, CYA, (also known as stabilizer or conditioner) prevents rapid breakdown of chlorine by sunlight and inhibits the corrosive effects of chlorine and bromine. Regulations may exist regarding use of Cyanuric acid in public pools; please consult your pool professional. Use the chart below to determine the amount of Cyanuric acid needed. Test water with a test kit that includes CYA testing, then use the chart below to determine the amount to add.

**KILOGRAMS OF CYANURIC ACID NEEDED FOR 75 PPM RESIDUAL**

CYA Level Before Addition	Pool / Spa Volume In 1000's of Litres								
	1	2.5	5	10	15	20	30	40	57
0 ppm	0.08	0.17	0.34	0.68	1	1.3	2	2.7	4
12 ppm	0.07	0.14	0.28	0.56	0.85	1.1	1.7	2.2	3.4
25 ppm	0.05	0.11	0.22	0.45	0.68	0.9	1.3	1.8	2.7
37 ppm	0.04	0.08	0.17	0.34	0.51	0.68	1	1.3	2
50 ppm	0.02	0.05	0.11	0.22	0.34	0.45	0.68	0.9	1.3
62 ppm	0.01	0.02	0.05	0.11	0.17	0.22	0.34	0.45	0.68

<b>NEEDED BY INSTALLER</b>	<b>SUPPLIED WITH CUBBY UNIT</b>
1) Required amount of salt	1) Residential Installation / Operation Manual
2) Hacksaw, Pipe Cutters or Cable Saw	2) Limited Warranty with Warranty Card (Must Return)
3) Tape measure & Permanent Marker	3) CUBBY Control Panel
4) Screwdrivers: Flat head & Phillips head	4) Chlorine/Bromine Production Cell Flow Detector With Tee (Where applicable) Cell Unions (Where applicable)
5) Pair of medium size needle nose pliers (For removal of the Output Control Dial)	5) Salt test strips & vial.
6) Drill with 6mm (1/4") masonry-drill bit for block or stucco	6) Installation kit, Including mounting hardware.
7) Voltmeter - To determine AC voltage to Control Panel	
8) Test kit for Chlorine/Bromine, Calcium Hardness, pH, Total Alkalinity, and Cyanuric Acid (stabilizer).	
9) P.V.C. Glue	
10) P.V.C. Cleaner / Primer	
11) Assorted P.V.C. Fittings & Pipe (Hose couplings & clamps for above ground pool projects)	
12) Assorted Electrical Hookup Components	
13) Teflon tape or pipe joint compound	
14) Large Channel Lock Pliers	

## Control Panel

Using the supplied anchors and screws, the Control Panel should be mounted on a flat, sturdy, vertical surface away from direct exposure to sunlight. The Control Panel is equipped with a 3.65 m DC cell cord and flow detector cord. For ease of installation, please ensure that both cords connect to the cell and flow detector while still providing slack in each cord for future service. Using a torpedo level and permanent marker, hold and level the Control Panel on the surface to be mounted and dot each of the (4) mounting holes. Using a .63 cm drill bit, drill to a depth of 2.5 cm and install the supplied anchors. The Control Panel is now ready to receive the (4) mounting screws to secure the installation.

**DO NOT SHOOT OR PERMANENTLY ATTACH THE CONTROL PANEL TO THE WALL! This will void the WARRANTY.**

**NOTE:** Install at least 1.53m from the inside wall of the pool or spa.

**CAUTION - YOU MUST REMOVE THE OUTPUT CONTROL DIAL BEFORE ATTEMPTING TO REMOVE THE COVER. FIRST PRY OFF THE CAP AT THE TOP OF THE KNOB, WHICH WILL REVEAL THE HEX NUT. LOOSEN THE NUT AND LIFT OFF THE KNOB.**

## Typical In-Line Equipment Power Connection (220V)

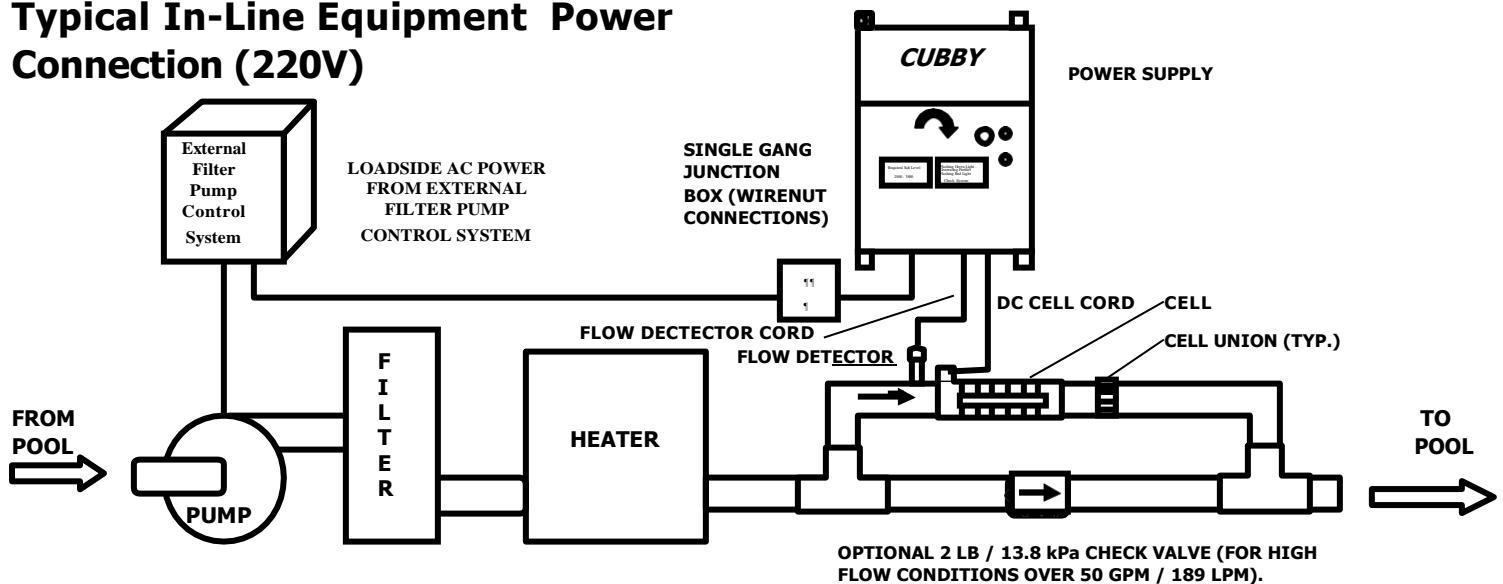

**NOTE 1 : FOR 24 HOUR OPERATION AS A "CONVECTION STYLE" INSTALLATION, SEE APPENDIX (PAGE 18)**

**NOTE 2: IF YOU NEED A TIME CLOCK FOR CONTROL OF THIS UNIT AND YOUR 110 VOLT POOL PUMP (PLUG IN), ASK ABOUT OUR PORTABLE TIME CLOCK .**

**NOTE:** See diagrams below for the proper location of the flow detector and cell, so not to over chlorinate/brominate the spa.

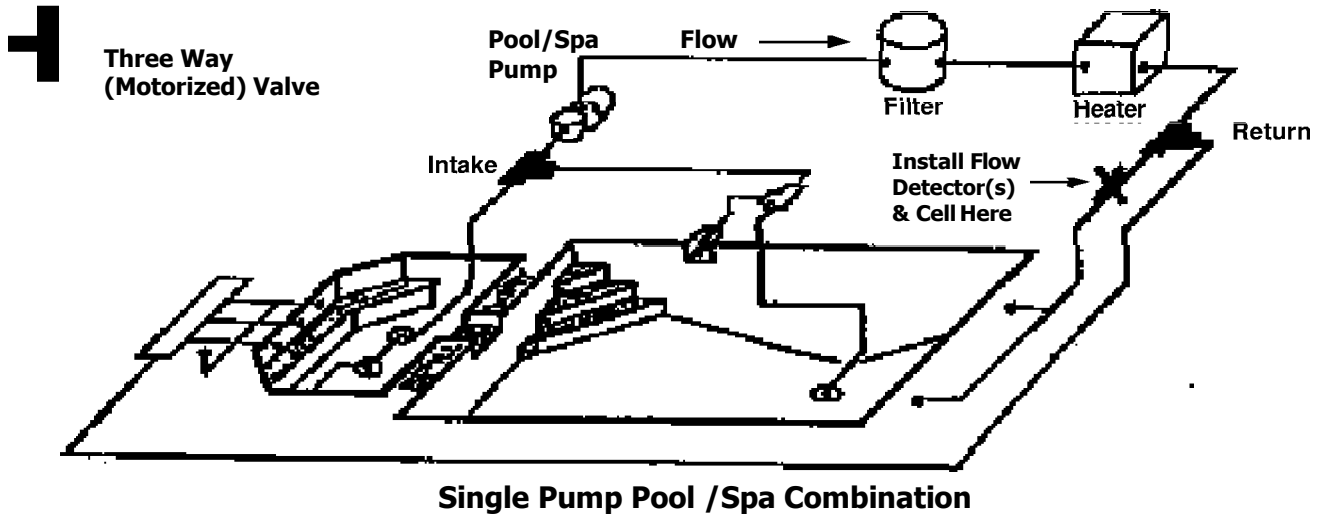

**NOTE:** If this scheme is desired and the spa is raised, a Swing Check Valve must be installed after the three way Return (Motorized) Valve on the Spa Jet line to ensure spa drain down does not occur.

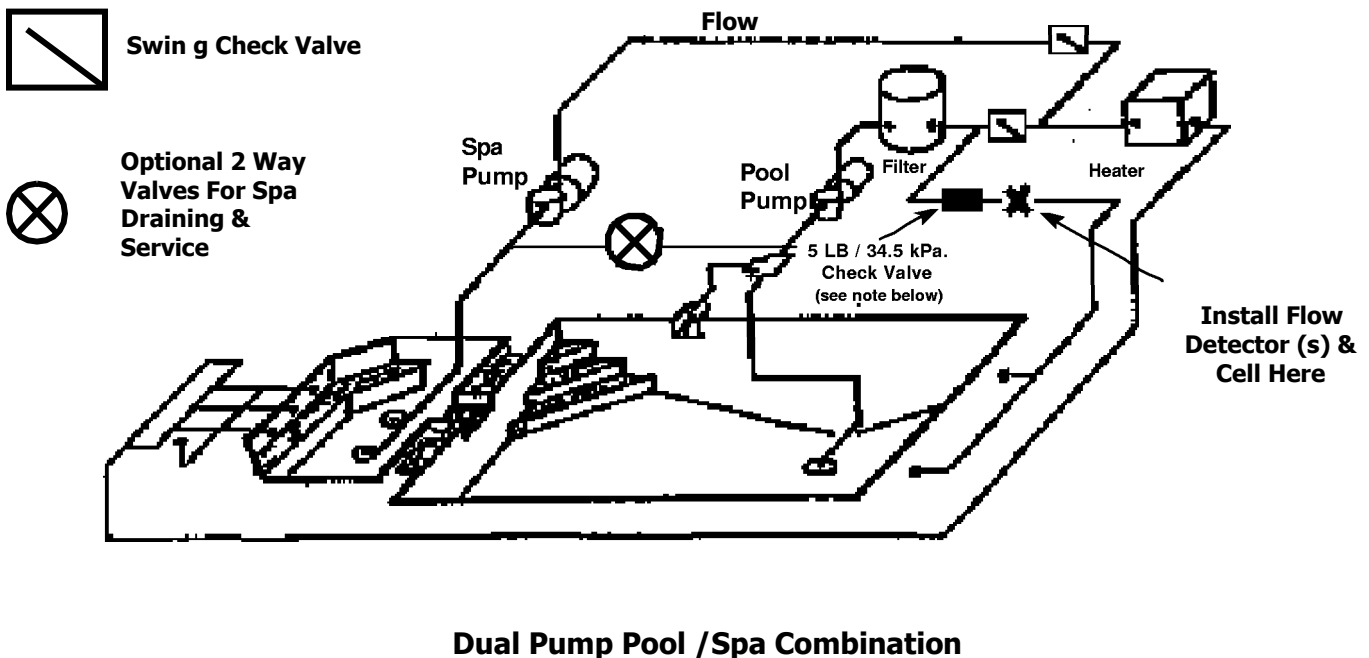

**NOTE:** If this scheme is desired and the spa is raised, a 5 LB / 34.5 kPa Check Valve must be installed on the Pool Return line before the flow detector to ensure adequate spa spillover.

## Section 3 a

# Control Panel Wiring

### **220V MODELS ONLY (You cannot switch to 110 volt power) STEP**

#### **1 - Wiring**

All electrical equipment must be located 1.50 m or more from closest pool or spa waterline. Use the green and yellow stranded wire for Control Panel grounding. Attach a #8 or #6 solid bond wire to the bonding lug on the underside of the unit.

**STEP 2 - Wire from the sub-panel** - Your CUBBY Control Panel is shipped factory set to 220 VAC ONLY. The Control Panel will operate at either 50Hz or 60Hz line power. Ensure that the filter pump AC voltage used matches the Control Panel voltage. Improper wiring will damage the Control Panel, which is not covered under warranty. Connect AC power to the blue and brown wires using wire nuts.

**STEP 2 a - Control Panel Hook-up** - Ensure that the main filter pump circuit breaker is set to OFF. Connect AC from the LOAD SIDE of the external time clock, Compool/Jandy filter pump relay or on/off switch to the CUBBY Control Panel so that it operates only while the filter pump operates. For flexibility, ease of wiring and making connections, #14 gauge stranded wire (2.1m) is recommended for interconnection between the external control system and the Control Panel. Wiring diagrams are located on the Control Panel's backplate. Plug the cell and flow switch cords into the bottom of the unit.

---

### **110V MODELS ONLY (You cannot switch to 220 volt power)**

**STEP 1** - Plug the CUBBY unit into a G.F.C.I. (Ground Fault Circuit Interrupter) protected outlet or timer.

**STEP 2** - Plug the 110V filter pump into the CUBBY unit AC outlet.

**WARNING** - This AC outlet is intended ONLY for the filter pump. DO NOT use for any other purpose.

---

### **Each CUBBY Automatic Sanitizing System consists of three (3) main components:**

1. The CONTROL PANEL converts incoming AC power to a Low Voltage DC current which energizes the Cell.
2. The CELL receives that Low Voltage DC current from the Control Panel, indicated by a flashing green OK indicator, which initiates the electrolytic process and allows purifier to be produced. This process converts salt (Sodium Chloride) to Sodium Hypochlorite which in turn purifies your pool. This salt then reverts back to ordinary salt and the entire process is repeated.
3. The FLOW DETECTOR ensures adequate flow is present to produce purifier. Further, it protects the Cell from damage caused by insufficient flow. If the flow rate drops below 57 LPM, the Control Panel will display a single red flashing CHECK SYSTEM indicator and the OK indicator will display dark.

### **BOTH MODELS**

**STEP 1** - Plug the cell cable into the cell and the other end into the 3 circuit connector located at the bottom right side of the CUBBY unit. It matches only one type connector, and it's keyed. You can't make a mistake.

**STEP 2** - Plug the flow switch cable into the WHITE 2- circuit connector closest to the wall at the bottom of the CUBBY unit. This input connector is keyed. See drawing top left page 17.

a) **ORP Controller** - Install part # 993 per the instructions provided.

**NOTE:** This is a dry contact input, **DO NOT ENERGIZE THIS INPUT! DAMAGE TO THE CONTROL PANEL WILL OCCUR AND THE WARRANTY WILL BE VOIDED.** When an ORP controller is interfaced to the CUBBY unit, your Output Control Dial should be set on 100%.

b) **Power Fuse** - On the Control Panel circuit board is a 2 amp power fuse labeled FS1 for the 110V unit, and a 1 amp fuse for the 220V unit. This fuse protects the Control Panel and cell from voltage spikes. If no lights display, inspection and possible replacement of this fuse may be necessary. The output control dial and cover must be removed from the unit to access this fuse.

## Control Panel Models AC3 and AC5

## Section 3 b

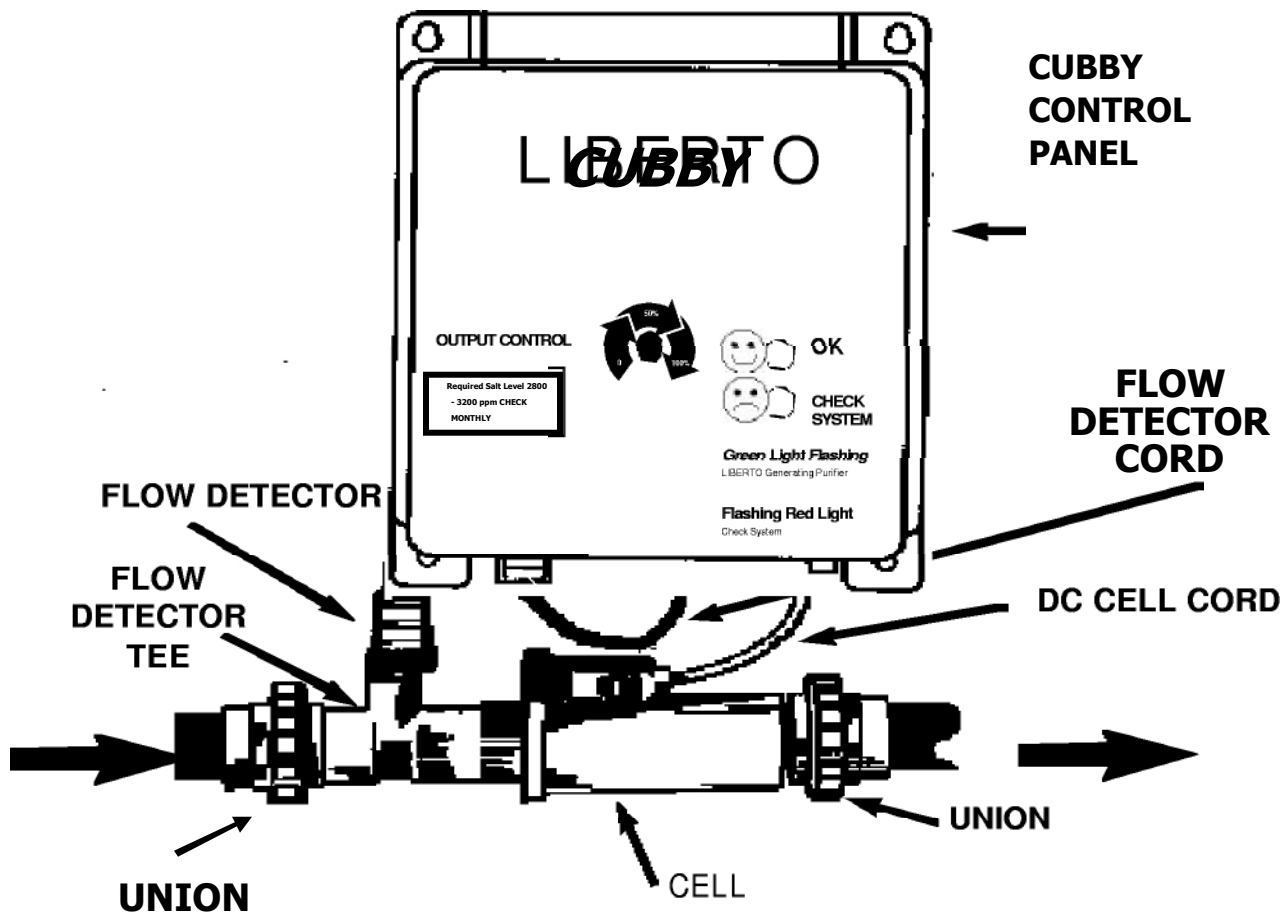



## Indicator Lights

### A. WHEN POWER IS FIRST TURNED ON:

The lights will flash alternately for one minute while the CUBBY unit self-tests and awaits continuous flow.

### B. OK:

If your CUBBY unit is wired properly, this indicator will display GREEN whenever the main filter pump is operating. This indicator ensures that proper incoming AC power is being delivered to the Control Panel. Further, this indicator will FLASH GREEN whenever the system is producing purifier, and display steady green when the cell is in rest mode.

### C. CHECK SYSTEM:

This indicator will display dark (OFF) whenever the Control Panel is operating correctly. While this indicator displays dark, rest assured that your pool is being purified by Hypochlorous Acid (from Sodium Hypochlorite) when the green OK indicator is flashing. For further explanation of this indicator, please refer to the Trouble Shooting Guide beginning on page 14.

## Output Control

The Output Control Dial is a percentage timer that regulates the amount of time the system is to produce chlorine/bromine during the filter pump running cycle. The output is regulated according to the setting of this dial. Each setting has a memory cycle of 36 minutes. The setting of the dial will determine how long the cell will produce chlorine/bromine and how long it will be in the rest mode. While in the rest mode your OK indicator will display steady green to indicate that no chlorine/bromine is being produced but the power is on. Below is a chart that indicates the on and off periods of each output setting.

NOTE: Any interruption of power, will cause the current memory cycle to reset itself when power is restored.

Dial Setting	Approx. On-Time	Approx. Rest-Time
0	0 min.	36 min.
50%	18 min.	18 min.
100%	36 min.	0 min.

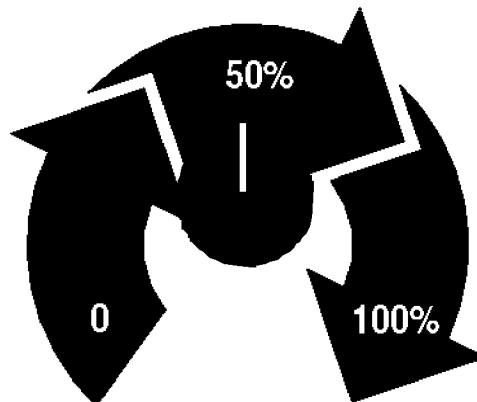

Use Of Sodium Bromide

*Once a bromine pool -Always a bromine pool.*

SODIUM BROMIDE (OPTIONAL) - 100 PPM

Where Cyanuric acid is not available or where its use is restricted, bromine can be used as an alternative purifier to chlorine. The CUBBY unit will convert sodium bromide to bromine in the same way that it converts sodium chloride to chlorine.

NOTE: Bromine pools do not require the addition of Cyanuric acid. Typical chlorine stabilizer provides no U.V. protection for bromine residuals. **DO NOT MAINTAIN OR ADD CYANURIC ACID TO A BROMINE POOL!**

To produce hypobromous acid (bromine purifier), we recommend initially adding 10.9 kg of sodium bromide for every 45,000 Litres of pool water capacity. To maintain the sodium bromide level add 1.8 kg of sodium bromide for every 22.5 kg of sodium chloride (salt) added to the pool.

REMEMBER: For the CUBBY System to operate properly, the pool water must contain the recommended level of both salts as previously specified. (When used, sodium bromide is added in addition to the normal amount of sodium chloride required.)

## Equipment Start Up Sequence

### Section 4 b

Before operating the CUBBY System, perform the following steps to ensure proper installation and operation:

- A. Turn ON all circuit breakers to the pool equipment.
- B. Set the output control dial at 50%.
- C. Switch on the main filter pump, the following indicators should display ..... a cycling green OK and red CHECK SYSTEM. This is normal and will last 1 minute. After sufficient flow is detected, greater than 56LPM, the green OK indicator should flash. If this sequence does not occur or any red indicators display, please refer to the Trouble Shooting Guide starting on page 14 for further assistance.

NOTE: Be sure to test the chlorine/bromine level for the next few days and properly adjust the chlorine/bromine output dial.  
**DO NOT EXCEED RECOMMENDED CHLORINE OR BROMINE LEVELS!**

As adjustments are required, make the adjustment and allow the pool to react to this change a minimum of 3 days. After the 3 days expire, retest the pool water and make any further adjustments if necessary. Typically, when an adjustment is made, the amount of time the main filter pump operates does not change. A simple rule to follow...

As the water temperature decreases, the purifier demand also decreases.

Lower the Output Control Dial to satisfy this change in purifier demand until it's necessary to raise the residual level. When the water temperature drops below 14°C, lower the Output Control Dial. In some cases, set it to the "0 (zero)" position. Do not allow chlorine or bromine residual to drop below minimum level. Because the water temperature is cooler, the purifier demand is lower, it is unnecessary to produce as much purifier as normally produced in warmer water. Further, this action protects the Cell from possible damage caused by operating below 14°C.

As the water temperature increases, the purifier demand also increases.

Raise the Output Control Dial and/or increase the main filter pump runtime to satisfy this change in purifier demand.

PROBLEM	CAUSE	SOLUTION
1. Insufficient purifier production.		
A. The test kit reagents or test strips are old or expired.		A. Retest with new reagents or test strips.
B. The unit is set too low in relation to an increased purifier demand		B. Turn up the output dial and/or increase the filter pump run time.
C. The bather load has increased.		C. Set the output control dial to 100 % and allow the filter pump to operate 24 hours (where applicable remove the "OFF" tripper from the external time clock) to super-chlorinate / brominate the water.
D. Purifier loss due to intense sunlight exposure.		D. Check the stabilizer level and add cyanuric acid if needed. (Refer to the Cyanuric Acid Needed for 75 PPM section, page 6.) If on bromine, replenish bromine residual.
E. The body of water being purified leaks.		E. Repair the leak and rebalance the water being purified. (Refer to the Pool Water Preparation section, page 5.)
F. Low salt		F. Check the residual salt level and add if necessary. (Refer to the Salt Requirements Needed for 3000 PPM section, page 6)
G. Flow cable plugged into wrong input.		G. Unplug cable from front input and plug into back input closest to wall.
2. Scale build-up within the cell.		
A. The water being purified contains high pH, alkalinity and calcium hardness.		A. Calculate Langelier's Index to assure balanced water. (See page 5) Adjust the water chemistry and mix 1 part muriatic acid to 4 parts water.  Pour this solution into the cell and allow it to clean the cell for no longer than 15 minutes. Repeat if necessary. Drain and rinse with fresh water and re-install. Dilute pool water with fresh water if necessary.
B. The unit is not reversing polarity		B. Confirm with a 504 or 957 cell tester that it is not reversing polarity. Send the control panel back to the factory for service..
C. Possible cell failure.		C. Check with either a 504 or 957 cell tester. Replace the cell if needed. Refer to #4 of this section.
3. DC plug and cell terminals burned.		
A. The cell cord plug is not securely pushed onto the cell allowing moisture to seep into the plug.		A. Ensure that the cell cord plug is pressed completely on the cell terminals terminal. Check the cell terminals and clean with a dry cloth to remove all dirt and corrosion.
B. The cell terminals leak.		B. Shut off the main filter pump and patch the cell terminal(s) with epoxy putty and leave the filter pump off for 24 hours.
C. Completely failed cell		C. Replace the cell.
4. Premature cell failure. (Requires replacement cell. Normal cell life, if sized and operated correctly, is 3 - 5 years.)		
A. Abnormally high cell usage due to an insufficient cyanuric acid level.		A. Check the stabilizer level and add cyanuric acid if needed. (Refer to the Cyanuric Acid Needed for 75PPM section, page 6.)
B. Debris in Cell		B. Inspect cell monthly and clean debris if required.
5. White flakes in the water.		
This occurs when excessive calcium hardness is present in the water being purified. This should cease after a few days.		Monitor the pH and adjust if necessary. (Refer to the Pool Water Preparation section, page 5.)
6. No OK light.		
A. Incoming AC power for the main filter pump is not present.		A. Ensure that the main filter pump circuit breaker is set to "ON".
B. Power fuse blown		B. Remove the knob and cover, replace this fuse.

PROBLEM	CAUSE	SOLUTION
---------	-------	----------

## 7. Single CHECK SYSTEM Flash

A. Water exiting the filter is being diverted away from the inlet of the flow detector	A. Increase the flow rate above 15 gallons (56 LPM) per minute to activate the flow detector.
B. Check the condition of the filter.	B. If the filter is dirty clean it.
C. Ensure that the flow detector is not installed upside in relation to the actual water flow.	C. Extract the flow detector & re-install if necessary.
D. The flow detector may have failed.	D. Replace the flow detector.

## 8. Double CHECK SYSTEM Flash

A. The cell is scaled.	A. See # 2.
B. The cell cord is disconnected from the cell.	B. Ensure that the cell cord is firmly pressed onto the cell.
C. Low salt	C. Check the residual salt level and adjust if necessary. (Refer to the salt requirements needed for 3,000 ppm section, page 6).
D. The unit is not reversing polarity.	D. Send the Control Panel back to factory for service.
E. Possible cell failure.	E. Check with either a 504 or 957 cell tester. Replace the cell if needed. Refer to #4 of this section.
F. Very cold pool water.	F. Lower the output control dial setting, even to the "0" position, and add a non-chlorine shock to the pool until the water temperature increases above 60° F (14°C).

## 9. Triple CHECK SYSTEM flash

A. Low cell voltage.	A. Check with either a 504 or 957 cell tester. A possible cell short circuit may exist. Replace the cell if needed. Refer to #4 of this section.
----------------------	--

## 10. Quadruple CHECK SYSTEM flash

A. No cell voltage or current.	A. Send the control panel back to the factory for service.
--------------------------------	--

## SUMMARY OF CUBBY UNIT OPERATING MODES

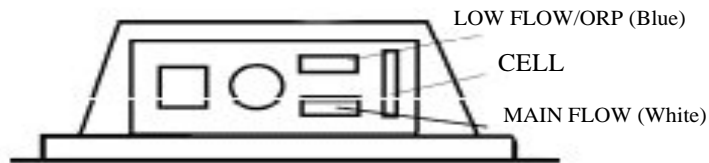

BOTTOM PANEL OF THE CUBBY UNIT

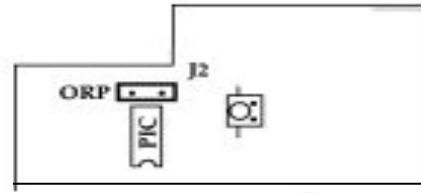

CUBBY UNIT PRINTED CIRCUIT BOARD

MODE	FUNCTION	LO FLOW /ORP	FLOW	J2
1	In-line operation	Not connected	Main flow switch	Open
2	2-speed pump (Generates reduced purifier when pump is at low speed)	Low flow switch	Main flow switch	Open
3	Partial convection (Generates reduced purifier by convection when pump is not running)	Shorting plug	Main flow switch	Open
4	Full convection (Continuously produces full purifier output by convection)	Not connected	Shorting plug	Open
5	ORP Controller Interface	ORP relay contacts(N.O.)	Main flow switch	Linked

1. 2 SPEED PUMP SYSTEMS ON SPAS AND SMALLER POOLS

- Add Low Speed Flow Switch Assembly

Most 2-speed circulation systems for pools and spas operate at high speed when the project is being used, and run at low speed when not in use. The demand for purifier may be many times greater when the project is being used than when it is not. To avoid overdose, add a Low Flow Switch Assembly.

When the CELL FLOW switch closes, the CUBBY unit delivers purifier at the rate set by the output control dial. If the CELL FLOW SWITCH opens, but the LO FLOW remains closed, purifier is generated at 12% of the output if the control dial is set at maximum.

The cell flow switch operates at 15 gpm (56 LPM). If a secondary flow switch, operating at 5 gpm (19 LPM.), is connected to the LOW FLOW / ORP (BLUE) input, the CUBBY unit will reduce its purifier output when the pump runs at low speed, a situation when the pool or spa is not normally in use. This mode of operation prevents overdosing, yet provides a purifier boost when the pool or spa is in use or the filter pump is operating in high speed mode.

2. CONVECTION APPLICATIONS - See Configurations 1 & 2 on pages 17 & 18.

Many above-ground pools benefit from continuous purification at a reduced rate when the pump is not running. This is done by permanently shorting the LO FLOW connector contacts with the white shorting plug connector supplied in the installation kit, yet continuing to use a flow switch for the MAIN FLOW input. This generates purifier at the rate set by the output control while the pump is running. When the pump is off, the CUBBY unit continuously generates purifier in convection mode at 12% of the output if the control dial is set at maximum.

In above-ground pool installations where the pump and filter are below the water level, the CUBBY unit may be operated in a convection mode. This requires the following:

- 1 The cell **MUST** be located immediately adjacent to the discharge outlet in a vertical position.
- 2 Unobstructed flow is required through the cell, whether the pump is operating or not. This can be accomplished by the method shown on page 18, using a check valve bypass run between the suction port and discharge outlet.
- 3 -Please do not install any shutoff valves on the bypass run between the suction port and discharge outlet or after the cell. Obstructing the flow at the bypass run or after the cell will cause damage.

**CONFIGURATION 1 : Typical End- of- line Cell Installation (With Flow Switch) Install per diagram below.**

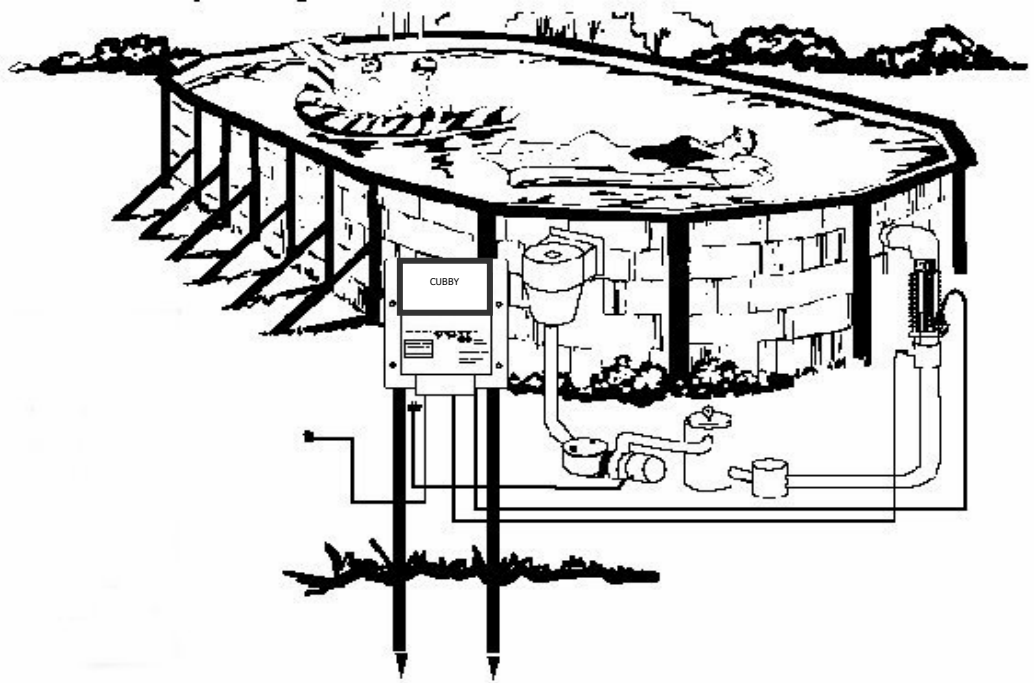

### Ground Mounting Kit

#### consists of:

(2) 91.5 cm - 1.9cm x 1.9cm x .3cm (3' - 3/4" x 3/4" x 1/8") aluminum angles with four predrilled 0.156 holes

(4) #10-32 .9 cm (3/8") S.S. screws. Two for each side installed within the back-plate mounting feet.

## OPTIONAL GROUND MOUNTING SUPPORT

## STEPS FOR INSTALLATION

### STEP 1

Choose an adequate location for your CUBBY Unit Control Panel. Read and follow warnings. Avoid traffic, lawn mowers and sprinklers. Take both 3 ft (1 m) aluminum angle stakes and drive into ground approximately 12" (31 cm) deep, to the width of the CUBBY Unit Control Panel 8 1/8" (21 cm) (Use a 2" X 4" (5 cm x 10 cm) block and hammer.)

### STEP 2

Slide the CUBBY Unit Control Panel over the angle stakes and screw into the predrilled holes.

**CAUTION: DO NOT HAMMER THE CUBBY UNIT WITH ANY TOOL.**

**CAUTION: DRIVE STAKES INTO GROUND BEFORE MOUNTING THE CUBBY UNIT CONTROL PANEL.**

Continued On Next Page

**CONFIGURATION 2: Typical End- of- line Convection Installation (Flow Switch Disabled)  
For 24 Hour Operation As A "Convection Style" Unit**

**OXYGEN BUBBLES GENERATED WITHIN THE CELL CAN BE UTILIZED TO CREATE FLOW.**

STEP 1 Disconnect the cell flow switch cable mounted with the cell. Plug the shorting plug (included in the convection installation kit) into the back 2-circuit connector input (plug closest to wall at bottom of Control Panel).

STEP 2 Install Convection Kit (per sketch). Cut pipe directly below skimmer and insert proper size solvent weld or flex hose tee; connect, as per diagram below, to second tee / check valve combination on input side of cell assembly.

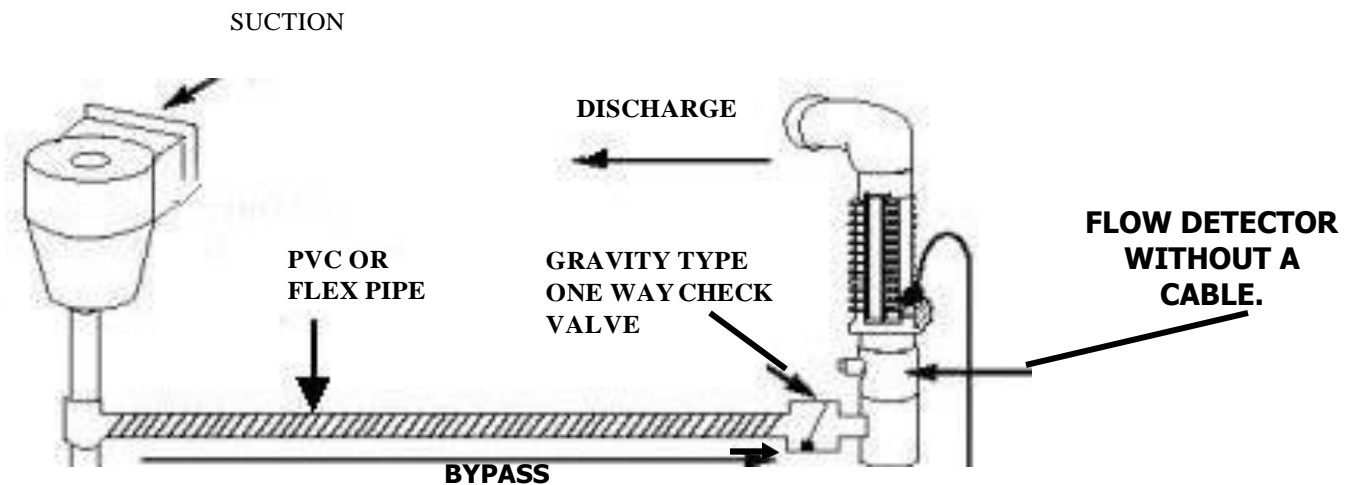

**IMPORTANT NOTES:**

1. The cell must be mounted vertically, with unobstructed free flow through the discharge outlet. This allows complete disbursement of gas bubbles generated during purifier production.
2. Convection illustration depicts a vertical cell (see sketch above) immediately adjacent to the discharge supplied by a direct bypass to avoid the flow restrictions of the circulation system.
3. The flow induced by the rising bubbles disperses the purifier generated into the volume even when the pump at rest. Activation of the pump closes a GRAVITY TYPE ONE WAY CHECK VALVE in the bypass run.
4. Pipe between the suction tee and check valve supplied by owner.

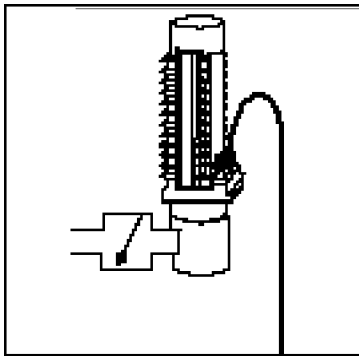

Gravity /flapper style check valves are normally installed with the hinge at the top, but it is not imperative in this application. In fact an inverted position allows the flapper to lay open with pump at rest offering absolute minimum restriction.

**To obtain service for your CUBBY system, contact the Dealer/Service Centre listed below, or:**

**Lectranator Systems, Inc.  
1034 - 72 Avenue N.E.  
Calgary, Alberta, Canada  
T2E 8V9 (403) 250-2494**

**If warranty service is being requested, you must provide a copy of your registered warranty card as proof of purchase. Warranty service cannot be performed without this documentation.**

<b>CUBBY DEALER</b>
---------------------

**WHEN CALLING FOR SERVICE - Please have the following information ready:**

**1. Control Panel Model: \_\_\_\_\_**

**2. Chlorine Cell Serial Number: \_\_\_\_\_**  
**(Located on top of cell, stamped in plastic)**

**3. Installation Date: MM: \_\_\_\_\_ DD: \_\_\_\_\_ YY: \_\_\_\_\_**

**4. Warranty Registration Number: \_\_\_\_\_**



