

2015-6332

2016-02-09

101
CD

IMPORTANT SAFETY RULES

**Read, Understand, and Follow all
Instructions Carefully before
Installing and using this Product.**

Krystal Clear™ Deluxe Saltwater System (salt in pool)

Model 8110



For illustrative purposes only.

To find out more about additional Intex products, please visit our website.

 **INTEX®**

IMPORTANT!

DO NOT RETURN PRODUCT TO STORE

To purchase parts and accessories or to obtain non-technical assistance,
Visit www.intexcorp.com

For technical assistance and missing parts call us toll-free (for U.S. and Canadian Residents):

1-800-234-6839

Monday through Friday, 8:30am to 5:00pm Pacific Time

101CD-R1-08--

OWNER'S MANUAL

TABLE OF CONTENTS

Warnings..... 3-4

Parts List & Reference..... 5-7

Product Information & Specifications..... 8

Set Up Instructions..... 9-13

Salt and Pool Water Volumes..... 14

Intex Pools Salt Table..... 15

Intex Pools Operating Time Table..... 16

Non-Intex Pools Salt Table..... 17

Non-Intex Pools Operating Time Table..... 17

Operating Instructions..... 18-19

Alarm Codes..... 20

LED Code Chart..... 21

Maintenance..... 22-24

Long Term Storage..... 24

INTEX 3-Way Test Strips..... 24

Pool Maintenance and Chemical Definitions..... 25

Troubleshooting Guide..... 26-27

General Aquatic Safety..... 28

Limited Warranty..... 29

Pool Safety Sign..... 30

Intex Service Center Locations..... 31

IMPORTANT SAFETY RULES

Read, Understand and Follow All Instructions Carefully Before Installing and Using this Product.

READ AND FOLLOW ALL INSTRUCTIONS

WARNING

- To reduce the risk of injury, do not permit children to use this product. Always supervise children and those with disabilities.
- Risk of electric shock. Connect this product only to a grounding type receptacle protected by a ground-fault circuit interrupter (GFCI). Contact a qualified electrician if you cannot verify that the receptacle is protected by a GFCI.
- Do not bury electrical cord. Locate cord where it will not be damaged by lawn mowers, hedge trimmers, and other equipment.
- To reduce the risk of electric shock, the supply cord cannot be replaced. If the cord is damaged, the appliance should be replaced immediately.
- To reduce the risk of electric shock, do not use extension cords, timers, plug adaptors or converter plugs to connect unit to electric supply; provide a properly located outlet.
- Assembly and disassembly by adults only.
- Do not attempt to plug in or unplug this product while standing in water or when your hands are wet.
- Do not use an appliance leakage current interrupter (ALCI) in place of a GFCI since the ALCI will not protect people.
- Position this product away from pool to prevent a child from climbing on product to access the pool.
- Children must stay away from this product and all electrical cords.
- Do not operate this product when pool is occupied.
- Always unplug this product from the electrical outlet before removing, cleaning, servicing or making any adjustment to the product.
- This product is intended to be used only for the purposes described in the manual!

FAILURE TO FOLLOW THESE WARNINGS MAY RESULT IN PROPERTY DAMAGE, ELECTRIC SHOCK, ENTANGLEMENT OR OTHER SERIOUS INJURY OR DEATH.

CAUTION

This product is for use with storable pools only. Do not use with permanently-installed pools. A storable pool is constructed so that it is capable of being readily disassembled for storage and reassembled to its original integrity. A permanently-installed pool is constructed in or on the ground or in a building such that it cannot be readily disassembled for storage.

These product warnings, instructions and safety rules provided with the product represent some common risks of water recreation devices and do not cover all instances of risk and danger. Please use common sense and good judgement when enjoying any water activity.

Follow all aspects of the local and National Electrical Code(s) when installing the **Krystal Clear™ Deluxe Saltwater System (salt in pool) Model 8110**.

For Portable, Above-The-Ground Pools Only

KRYSTAL CLEAR™ DELUXE SALTWATER SYSTEM (SALT IN POOL) MODEL 8110

110 – 120 V~, 60 Hz, 2.5 A
THERMALLY PROTECTED
WEATHERPROOF ENCLOSURE
CSA ENCLOSURE 3
DOUBLE INSULATED AND GROUNDED
FOR USE WITH SWIMMING POOLS ONLY.

CAUTION

FOR CONTINUED PROTECTION AGAINST POSSIBLE ELECTRIC SHOCK,
USE ONLY IDENTICAL REPLACEMENT PARTS WHEN SERVICING.

IMPORTANT

READ THE LABEL AND OWNER'S MANUAL BEFORE USING.

KRYSTAL CLEAR™ DELUXE SALTWATER SYSTEM (SALT IN POOL) MODEL 8110

CONTROLS BACTERIA AND ALGAE in Storable Swimming pool Waters.
Domestic.

A Maximum of 55,000 L (14,530 gal) of water can be treated with one **Krystal Clear™ Deluxe Saltwater System (salt in pool) Model 8110** unit.

Maximum output of hypochlorous acid equivalent to 0.225 kg (0.495 lb) of free available chlorine per day.

For swimming pools, a minimum of 1 ppm of free available chlorine must be maintained.
READ THE LABEL AND OPERATING MANUAL BEFORE USING.

KEEP OUT OF REACH OF CHILDREN.

REGISTRATION NO. 28190 PEST CONTROL PRODUCTS ACT.

Registrant: Intex Trading (Hong Kong) Ltd., Jth floor Dah Sing Financial Center, 108
Gloucester Road, Wanchai, Hong Kong

Canadian Agent: The Canadian Group, 430 Signet Drive Suite A, Toronto, Ontario M9L2T6,
Canada 1-800-234-6839

WARNING

Operating **Krystal Clear™ Deluxe Saltwater System (salt in pool) Model 8110**
without water flow through the cell can cause a build up of flammable gases
which can result in FIRE OR EXPLOSION.







WARNING

RISK OF ELECTRIC SHOCK.
CONNECT ONLY TO GROUNDING TYPE RECEPTACLE PROTECTED BY A CLASS
A GROUND FAULT CIRCUIT INTERRUPTER (GFCI).

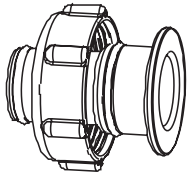
LED	DEFINITIONS
88	Start-up
90	Low Water Flow / No Flow
91	Low Salt Level
92	High Salt Level
93	Operating Process Finished

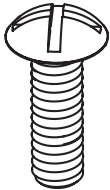
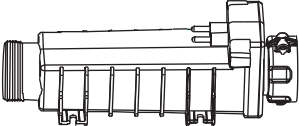
PARTS LIST

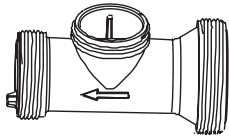
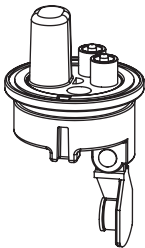
PARTS LIST

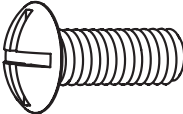
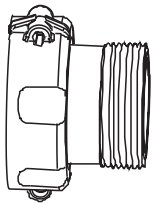
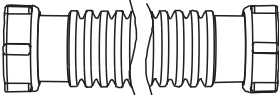
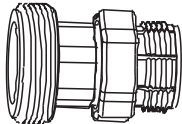
<p>1</p>  <p>* Optional</p>	<p>2</p> 	<p>3</p> 
<p>4</p> 	<p>5</p> 	<p>6</p> 
<p>7</p> 	<p>8</p> 	<p>9</p> 
<p>10</p> 	<p>11</p> 	<p>12</p>  <p>* Optional</p>

NOTE: Drawings for illustration purpose only. May not reflect actual product. Not to scale.

PARTS REFERENCE

Before assembling your product, please take a few minutes to check the contents and become familiar with all the parts.

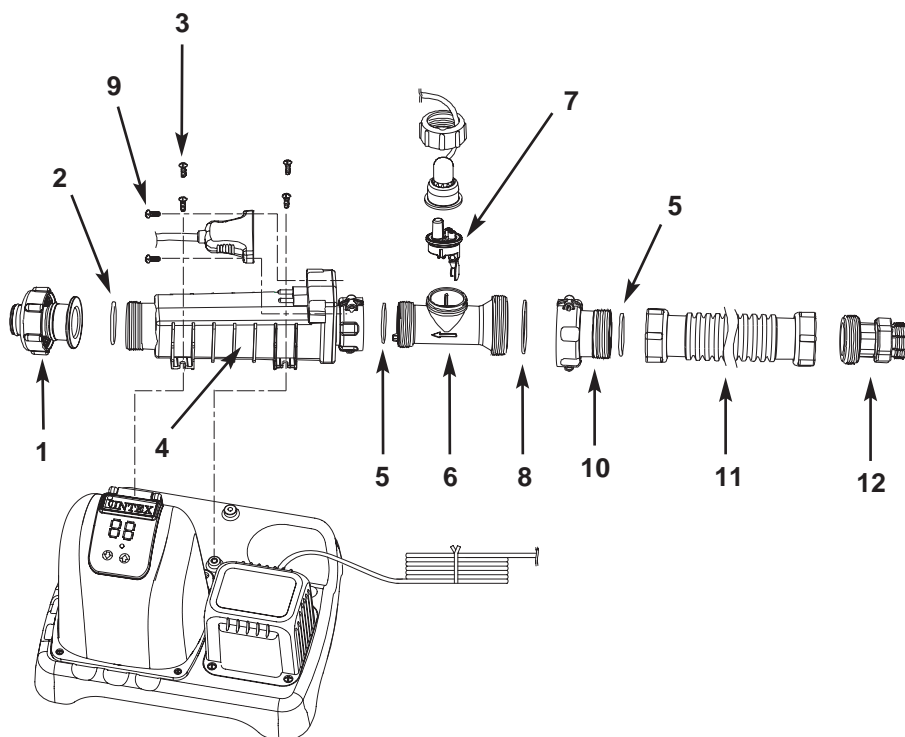

NOTE: Drawings for illustration purpose only. May not reflect actual product. Not to scale.

Operation is subject to the following two conditions: (1) this device may not cause interference, and (2) this device must accept any interference, including interference that may cause undesired operation of the device.

Changes or modifications not expressly approved by the party responsible for compliance could void the user's authority to operate the equipment.

This equipment has been tested and found to comply with the limits for Class B digital device, pursuant to part 15 of the FCC Rules. These limits are designed to provide reasonable protection against harmful interference in a residential installation. This equipment generates, uses and can radiate radio frequency energy and, if not installed and used in accordance with the instructions, may cause harmful interference to radio or television reception, which can be determined by turning the equipment off and on, the user is encouraged to try to correct the interference by one or more of the following measures:

- Reorient or relocate the receiving antenna.
- Increase the separation between the equipment and the receiver.
- Connect the equipment into an outlet on a circuit different from that to which the receiver is connected.
- Consult the dealer or an experienced radio/TV technician for help.

PARTS REFERENCE (continued)

Before assembling your product, please take a few minutes to check the contents and become familiar with all the parts.

REF. NO.		DESCRIPTION	QTY.	SPARE PART NO.
COMMON	FOR CONNECTION TO FILTER PUMPS WITH 32MM (1-1/4") HOSE SIZE			
	1	ADAPTOR A WITH THREADED COLLAR (OPTIONAL)	1	10849
2		O-RING A	1	10712
3		SCREW	4	10713
4		ELECTROLYTIC CELL (WITH TITANIUM PLATES) (O-RING A INCLUDED)	1	10888
5		O-RING B	2	10715
6		FLOW SENSOR CONDUIT (O-RING B & O-RING C INCLUDED)	1	10887
7		FLOW SENSOR	1	11143
8		O-RING C	1	10717
9		SHORT SCREW	2	10881
10		SCREEN FITTING WITH THREADED COLLAR (O-RING B INCLUDED)	1	10719
11		CONNECTOR HOSE WITH THREADED FITTINGS	1	10720
	12	THREADED ADAPTOR B (OPTIONAL)	1	10722

HOW THE CHLORINE IS GENERATED

Common salt (sodium chloride) is made up of two elements, sodium and chloride. During the installation of your Saltwater System, a measured quantity of salt is dissolved in the pool water to make it slightly salty. This pool water is passed through the Saltwater System's electrolytic cell to produce chlorine which is dissolved instantly in the water. The chlorine instantly starts to destroy bacteria, algae and oxidizes other organic materials.

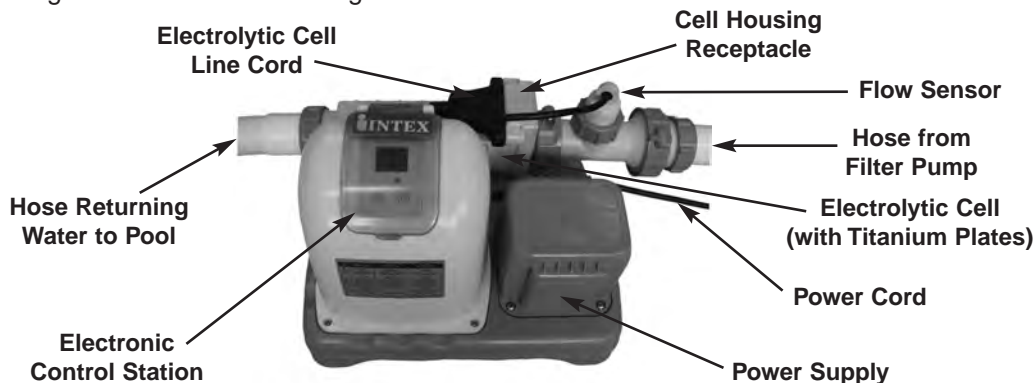

Key Saltwater System Parts:

- **Power Supply**
The power supply converts AC electrical current to a low voltage DC current. This is required by the cell to perform the electrolysis that creates chlorine.
- **Electrolytic Cell (with Titanium Plates)**
The electrolytic cell contains bipolar titanium electrodes which perform the electrolysis and produce liquid chlorine when energized with DC electricity. Chlorine is generated when pool water containing salt passes through the cell. The chlorine production can be varied by changing the number of hours the Saltwater System is operating each day. The Saltwater System has a built-in self cleaning cycle that operates every twenty hours without interrupting chlorine production.
- **Flow Sensor**
The flow sensor protects the electrolytic cell and ensures there is adequate water flowing through the cell. When the water flow drops below minimum flow rate, the electrolytic cell will automatically shut down to protect the titanium plates. A safety buzzer will sound and the LED display panel will show a signal code (see "LED Code Chart") indicating the problem.
- **Electronic Control Station**
The electronic control station contains an LED display panel and a set of pushbuttons to program the Saltwater System operating hours. It also monitors the different parameters such as salt level, water flow and the electrolytic cell activity. If any deviation from the norm occurs then a buzzer will sound and the LED display panel will show a signal code (see "LED Code Chart") indicating the problem.

PRODUCT SPECIFICATIONS

Power:	110 - 120 Volt AC
Amperage:	2.5 A
Wattage:	250W
Ideal Salt Level:	3000 ppm (parts per million)
Maximum Chlorine Output/hour:	24 grams/hour
Minimum Flow Rate:	700 ~ 4000 gallons/hour (2650 - 15140 liters/hour)
Limited Warranty:	2 Years (see "Limited Warranty")

SET-UP INSTRUCTION

IMPORTANT

The Saltwater System must be installed as the last piece of pool equipment in the water return line to the pool as displayed in Drawing #1. This location extends the life of the titanium plates.

1. Assemble the above-ground-pool (AGP) and its filter pump per installation instructions.
2. Remove the Saltwater System and its accessories from the packaging.
3. Place the Saltwater System in line after the filter pump.
4. Connect the connector hose (11) to the Saltwater System inlet.

For connection to filter pumps with 32mm (1-1/4") hose size:
Drawing #1

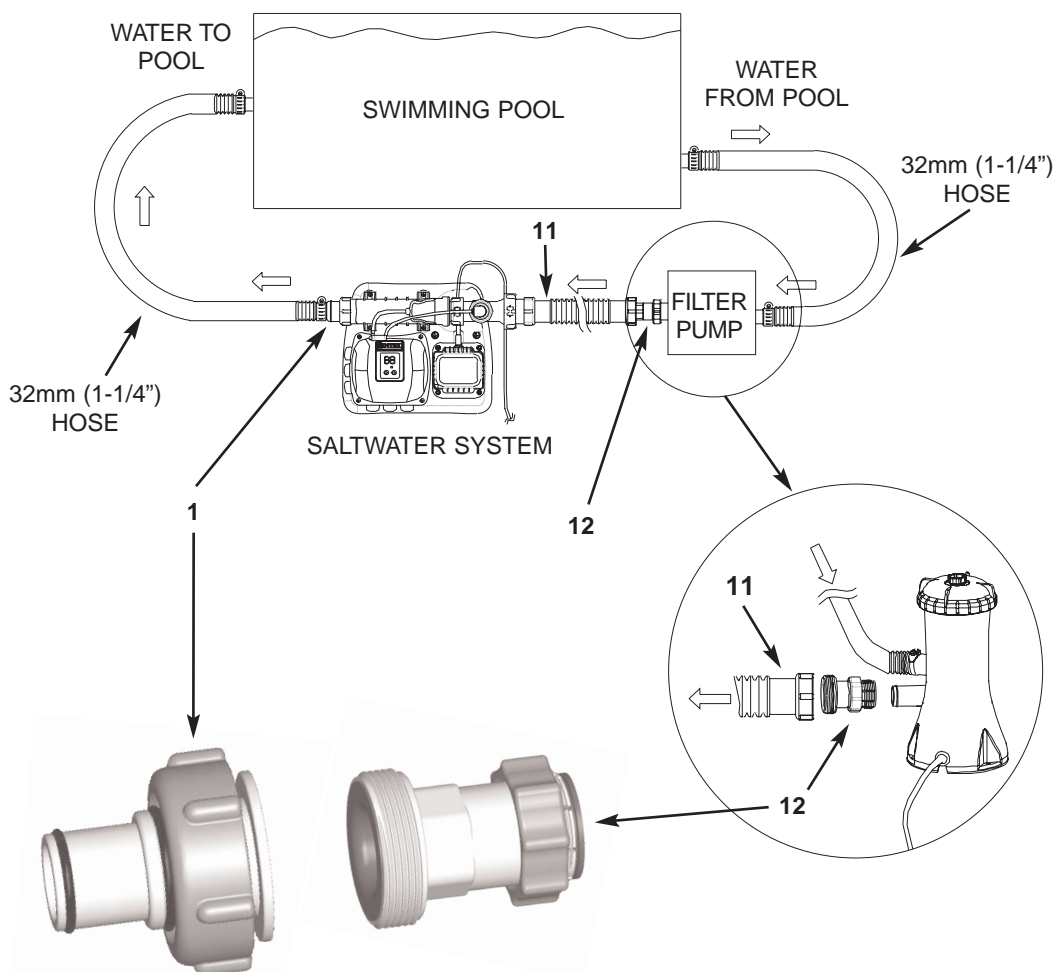

SET-UP INSTRUCTION (continued)

1. If your above-ground-pool is filled up with water, unscrew the strainer grids from the strainer connectors and insert the black hat-like plugs into the strainer connectors before saltwater pool system installation. Go to step 2 directly if your pool is empty.
2. Connect the adaptor A (1) to the electrolytic cell (4) outlet as shown in Drawing #1. Tighten securely.

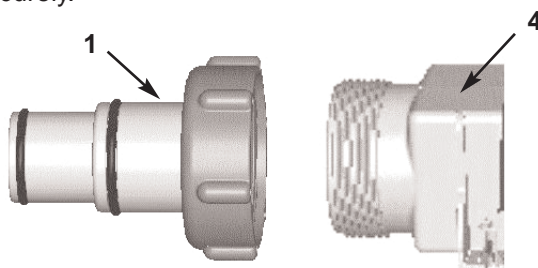

3. Disconnect the water return (to the pool) hose from the filter pump connection, and connect it to the adaptor A (1) on the Saltwater System with a hose clamp. (see Drawing #1)
4. Connect adaptor B (12) to the connector hose (11). Tighten securely. (see Drawing #1)

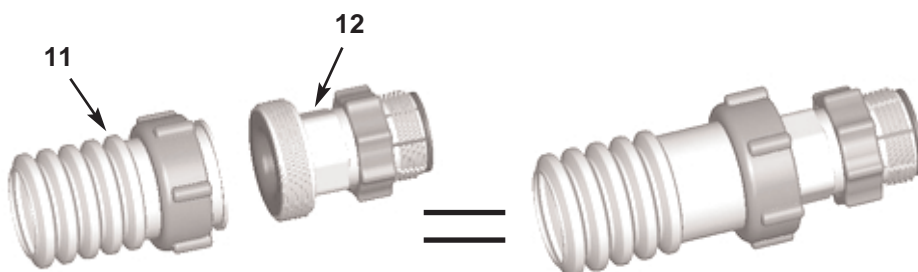

5. Connect adaptor B (12) to filter pump outlet connection (lower connection). Tighten securely.



6. Return strainer grids to strainer connectors inside pool after removing black hat-like plugs that prevented water from flowing out of the pool.

SET-UP INSTRUCTION (continued)

For connection to filter pumps with 38mm (1-1/2") hose size:

(Do not use adapter A (1) or B (12))

Drawing #2

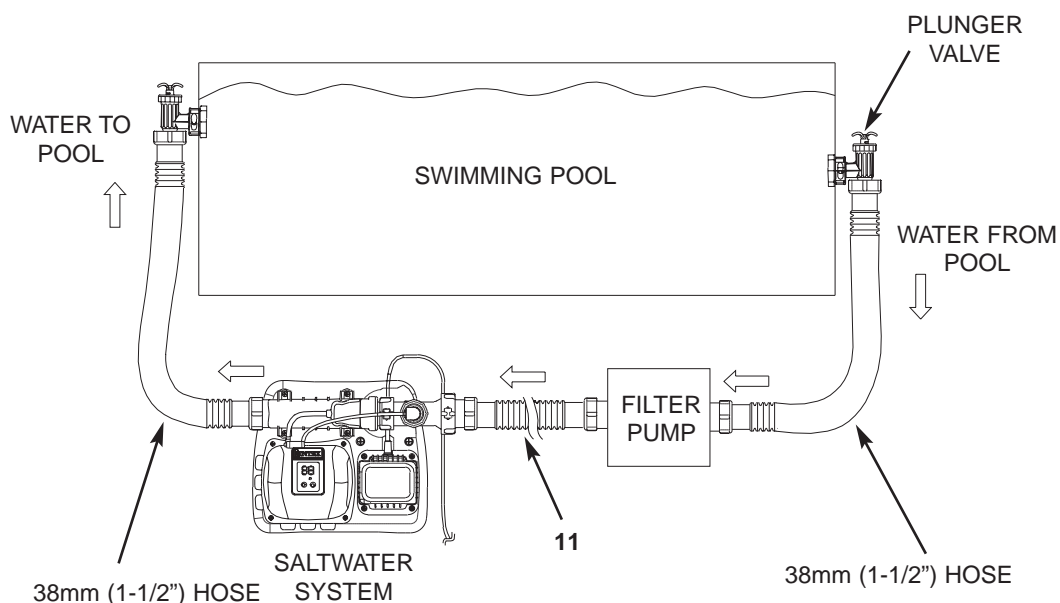

1. If your above-ground-pool is filled with water, close the plunger valves before Saltwater System installation. Go to step 2 directly if your pool is empty.
2. Disconnect the water return (to the pool) hose from the filter pump connection, and connect it to the Saltwater System outlet.
3. Connect the connector hose (11) to the filter pump outlet connection.
4. Open plunger valves to allow water to flow.

SET-UP INSTRUCTION (continued)

For connection to other filter pump (with different type of thread or no thread):

Saltwater System can also adapt to other filter pumps for those with different thread or without thread on the connection.

- **Connect to 32mm (1-1/4") filter pump outlet connection:**

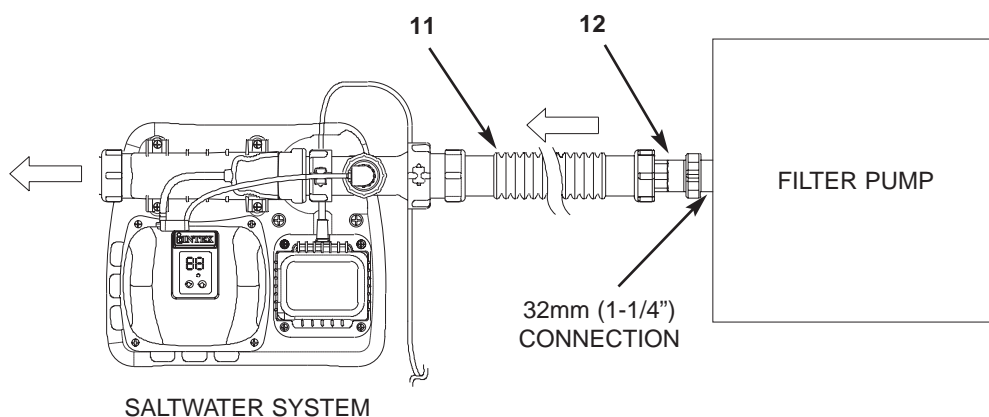

1. Connect adaptor B (12) to the connector hose (11). Tighten securely.
2. Connect adaptor B (12) to filter pump outlet connection. Tighten securely.

- **Connect to 38mm (1-1/2") filter pump outlet connection:**

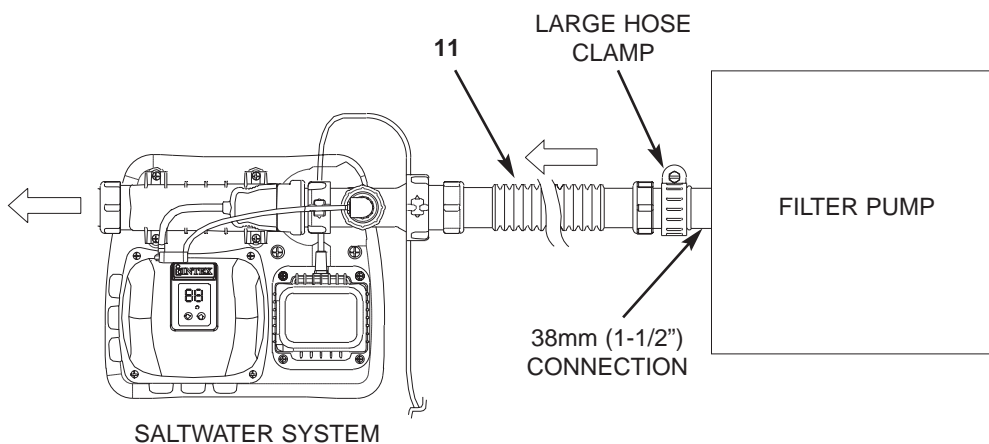

1. Connect the connector hose (11) to the filter pump outlet connection with a large hose clamp. Tighten securely.

SET-UP INSTRUCTION (continued)

- **Connect to 32mm (1-1/4") hose:**

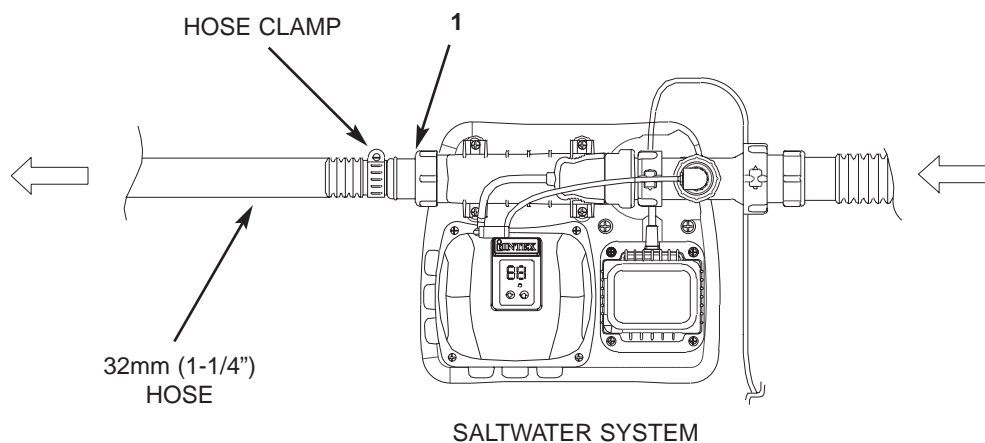

1. Connect the adaptor A (1) to the electrolytic cell (4) outlet. Tighten securely.
2. Connect the water return (to the pool) hose to the adaptor A (1) on the Saltwater System with a hose clamp.

- **Connect to 38mm (1-1/2") hose:**

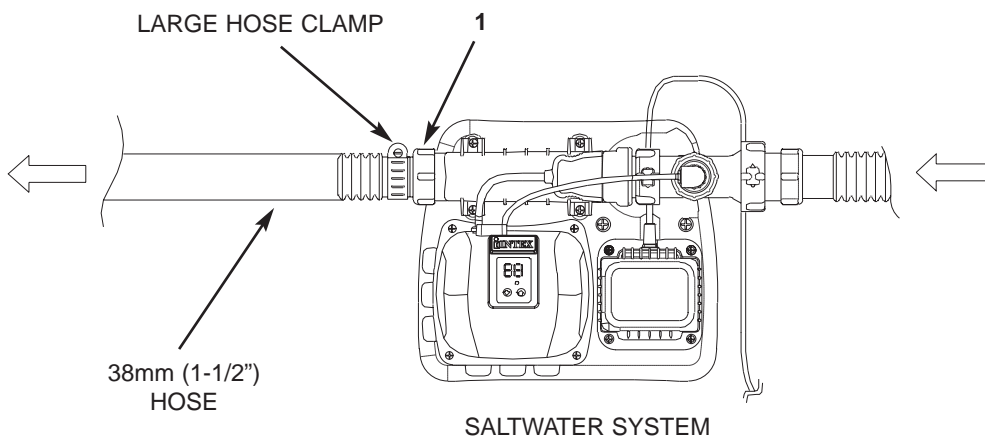

1. Connect the adaptor A (1) to the electrolytic cell (4) outlet. Tighten securely.
2. Connect the water return (to the pool) hose to the adaptor A (1) on the Saltwater System with a large hose clamp.

SALT & POOL WATER VOLUMES

Use only Sodium Chloride Salts

Use only sodium chloride (NaCl) salt that is at least 99.8% pure. It is also acceptable to use water conditioning salt pellets (the compressed forms of evaporated salt), but it will take longer time for them to dissolve. **Do not use iodized or yellow (yellow prussiate of soda) colored salt.** Salt is added to the pool water and the electrolytic cell uses this salt to create chlorine, the purer the salt the better the performance of the electrolytic cell.

Optimum Salt Levels

The ideal salt level in the pool water is between 2500-3500 ppm (parts per million) with 3000 ppm being optimal.

A too low salt level will reduce the efficiency of the Saltwater System and result in low chlorine production. A high salt level may begin to generate a salty taste to your pool water (this may occur at a salt level above 3500-4000 ppm). Too high of a salt level may damage the power supply and cause corrosion to pool metal fixtures and accessories. The following "salt table" shows the quantity of salt to use. The salt in the pool is constantly recycled. Salt loss is due only to pool water physically removed from the pool. Salt is not lost due to evaporation.

How to Add or Remove Salt

Adding Salt

1. Depress the ON button on the filter pump switch to circulate pool water.
2. Keep the Saltwater System "OFF".
3. Determine the amount of salt to be added (see "Salt Table").
4. Evenly spread the proper amount of salt around the inside perimeter of the pool.
5. To avoid clogging the filter, do not add salt through the skimmer.
6. Brush the pool bottom to speed up the dissolving process. Do not allow salt to pile up on the bottom of the pool. Run the filter pump 24 consecutive hours to thoroughly dissolve the salt.
7. After 24 hours and if all the salt is dissolved, turn on the Saltwater System and set the saltwater pool system to desired operating time (see "Operating Time Table").

Removing Salt

If too much salt has been added, the unit will beep and display "code 92" (see "Alarm Codes"). You need to lower the salt concentration. The only way to lower the salt concentration is to partially drain the pool and refill with fresh water. Drain and refill approximately 20% of the pool's water until the "Code 92" disappears.

Pool Volume Calculation

Types of Pool	Gallons (pool size in feet)	Cubic Meters (pool size in meters)
Rectangular	Length x Width x Average Depth x 7.5	Length x Width x Average Depth
Circular	Length x Width x Average Depth x 5.9	Length x Width x Average Depth x 0.79
Oval	Length x Width x Average Depth x 6.0	Length x Width x Average Depth x 0.80

INTEX POOLS SALT TABLE

This table shows how much salt to use to achieve the desired 3000 ppm salt level and how much will be needed to maintain this level if it drops below this desired level.

Pool Size	Water Capacity (Calculated at 90% for Frame Pool and 80% for Easy Set & Oval Pool)		Salt Needed for Startup 3.0g/L (3000 ppm)		Salt Needed when Low Salt Detected (CODE "91")		
	(Gals)	(Liters)	(Lbs)	(Kgs)	(Lbs)	(Kgs)	
INTEX ABOVE GROUND POOLS (AGP's)							
EASY SET® POOL	457cm x 91cm (15' x 36")	2822	10681	65	30	20	10
	457cm x 107cm (15' x 42")	3284	12430	80	35	20	10
	457cm x 122cm (15' x 48")	3736	14141	95	45	20	10
	488cm x 107cm (16' x 42")	3754	14209	95	45	20	10
	488cm x 122cm (16' x 48")	4273	16173	110	50	30	15
	549cm x 107cm (18' x 42")	4786	18115	120	55	30	15
	549cm x 122cm (18' x 48")	5455	20647	135	60	30	15
CIRCULAR METAL FRAME POOL	457cm x 91cm (15' x 36")	3282	12422	80	35	20	10
	457cm x 107cm (15' x 42")	3861	14614	100	45	20	10
	457cm x 122cm (15' x 48")	4440	16805	110	50	30	15
	488cm x 122cm (16' x 48")	5061	19156	125	55	30	15
	488cm x 132cm (16' x 52")	5501	20821	135	60	30	15
	549cm x 122cm (18' x 48")	6423	24311	160	75	40	20
	549cm x 132cm (18' x 52")	6981	26423	175	80	40	20
	732cm x 122cm (24' x 48")	11483	43462	290	130	75	35
ULTRA FRAME POOL	732cm x 132cm (24' x 52")	12481	47241	310	140	85	40
	488cm x 122cm (16' x 48")	5061	19156	125	55	30	15
SEQUOIA SPIRIT™ POOL SET	549cm x 132cm (18' x 52")	6981	26423	175	80	40	20
	508cm x 124cm (16'8" x 49")	5061	19156	125	55	30	15
OVAL FRAME POOL	549cm x 135cm (18'8" x 53")	6981	26423	175	80	40	20
	549cm x 305cm x 107cm (18' x 10' x 42")	2885	10920	75	35	20	10
	610cm x 366cm x 122cm (20' x 12' x 48")	4393	16628	110	50	30	15
	732cm x 366cm x 122cm (24' x 12' x 48")	5407	20465	132	60	35	15
RECT. ULTRA FRAME POOL	853cm x 366cm x 122cm (28' x 12' x 48")	6420	24300	150	70	40	20
	549cm x 274cm x 132cm (18' x 9' x 52")	4545	17203	115	50	30	15
	732cm x 366cm x 132cm (24' x 12' x 52")	8403	31805	210	95	60	30
	975cm x 488cm x 132cm (32' x 16' x 52")	14364	54368	365	165	95	45

INTEX POOLS OPERATING TIME TABLE

This table shows the operating time required for normal use of the Saltwater System with AGP's.

Pool Size		Water Capacity (Calculated at 90% for Frame Pool and 80% for Easy Set & Oval Pool)		Operating Time (hours) at different ambient/air temperatures			
		(Gals)	(Liters)	10 - 19°C (50 - 66°F)	20 - 28°C (68 - 82°F)	29 - 36°C (84 - 97°F)	37 - 42°C (99 - 108°F)
INTEX ABOVE GROUND POOLS (AGP's)							
EASY SET® POOL	457cm x 91cm (15' x 36")	2822	10681	1	3	3	3
	457cm x 107cm (15' x 42")	3284	12430	1	3	3	3
	457cm x 122cm (15' x 48")	3736	14141	2	3	3	3
	488cm x 107cm (16' x 42")	3754	14209	2	3	3	3
	488cm x 122cm (16' x 48")	4273	16173	2	3	3	4
	549cm x 107cm (18' x 42")	4786	18115	3	4	5	6
	549cm x 122cm (18' x 48")	5455	20647	3	4	5	6
	549cm x 132cm (18' x 52")	5894	22309	3	5	6	7
CIRCULAR METAL FRAME POOL	457cm x 91cm (15' x 36")	3282	12422	1	3	3	3
	457cm x 107cm (15' x 42")	3861	14614	2	3	3	3
	457cm x 122cm (15' x 48")	4440	16805	3	3	3	4
	488cm x 122cm (16' x 48")	5061	19156	3	4	5	6
	488cm x 132cm (16' x 52")	5501	20821	3	4	5	6
	549cm x 122cm (18' x 48")	6423	24311	4	5	6	7
	549cm x 132cm (18' x 52")	6981	26423	4	5	6	7
	732cm x 122cm (24' x 48")	11483	43462	7	9	10	11
732cm x 132cm (24' x 52")	12481	47241	8	10	11	12	
ULTRA FRAME POOL	488cm x 122cm (16' x 48")	5061	19156	3	4	5	6
	549cm x 132cm (18' x 52")	6981	26423	4	5	6	7
SEQUOIA SPIRIT™ POOL SET	508cm x 124cm (16'8" x 49")	5061	19156	3	4	5	6
	549cm x 135cm (18'8" x 53")	6981	26423	4	5	6	7
OVAL FRAME POOL	549cm x 305cm x 107cm (18' x 10' x 42")	2885	10920	1	3	3	3
	610cm x 366cm x 122cm (20' x 12' x 48")	4393	16628	2	4	5	6
	610cm x 366cm x 132cm (20' x 12' x 52")	4738	17935	3	4	5	6
	732cm x 366cm x 122cm (24' x 12' x 48")	5407	20465	3	4	5	6
	732cm x 366cm x 132cm (24' x 12' x 52")	5832	22073	3	5	6	7
	853cm x 366cm x 122cm (28' x 12' x 48")	6420	24300	4	5	6	7
	853cm x 366cm x 132cm (28' x 12' x 52")	6925	26211	4	5	6	7
	975cm x 366cm x 122cm (32' x 12' x 48")	7434	28137	5	6	7	8
	1,219cm x 366cm x 122cm (40' x 12' x 48")	9461	35809	6	8	9	10
RECT. ULTRA FRAME POOL	549cm x 274cm x 132cm (18' x 9' x 52")	4545	17203	3	4	5	6
	732cm x 366cm x 122cm (24' x 12' x 48")	7757	29359	5	6	7	8
	732cm x 366cm x 132cm (24' x 12' x 52")	8403	31805	5	6	7	8
	975cm x 488cm x 132cm (32' x 16' x 52")	14364	54368	9	11	12	12

NON INTEX POOLS SALT TABLE

Water Capacity (Calculated at 90% for Frame Pool and 80% for Easy Set & Oval Pool)		Salt Needed for Startup		Salt Needed when Low Salt Detected (CODE "91")	
(Gals)	(Liters)	(Lbs)	(Kgs)	(Lbs)	(Kgs)
2000	7500	50	20	10	5
4000	15000	100	45	25	10
6000	22500	150	65	40	20
8000	30000	200	90	55	25
10000	37500	250	110	70	30
12000	45500	300	135	80	35
14000	53000	350	160	95	45

SALT CALCULATION FOR POOLS

Salt Needed for Startup (Lbs)	Salt Needed for Startup (Kgs)	Salt Needed when Low Salt Detected (Lbs)	Salt Needed when Low Salt Detected (Kgs)
Water Capacity (Gals) x 0.025	Water Capacity (Liters) x 0.003	Water Capacity (Gals) x 0.0067	Water Capacity (Liters) x 0.0008

NON INTEX POOLS OPERATING TIME TABLE

Water Capacity		Operating Time (hours) at different ambient/air temperatures			
(Gals)	(Liters)	10 - 19°C (50 - 66°F)	20 - 28°C (68 - 82°F)	29 - 36°C (84 - 97°F)	37 - 42°C (99 - 108°F)
2000	7500	1	2	2	3
4000	15000	2	3	3	3
6000	22500	4	5	6	7
8000	30000	5	6	7	8
10000	37500	6	8	9	10
12000	45500	9	10	11	12
14000	53000	10	11	12	12



OPERATION INSTRUCTIONS

After the salt is dissolved, but before starting the Saltwater System be sure that:





- The entire filtering and chlorinating system is connected to a grounding type receptacle protected by a ground-fault circuit interrupter (GFCI).
- The filter pump operates several minutes before starting the Saltwater System (This removes air pockets and debris in the water hoses).
- No air is trapped in any of the hoses (Follow the Filter Pump Owner's manual to release any trapped air).

1. Plug the power cord into the electrical outlet. Switch on the unit. Code "88" appears on the electronic control station's LED indicating the unit is in a Stand-By Mode, this is normal.

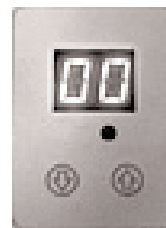

2. Unlock keypad controls: Press and hold  button for 2 seconds until you hear a short "beep", then press and hold  button for another 2 seconds until you hear the second short "beep", LED flashes "00". This procedure unlocks the keypad control buttons.





3. Set Saltwater System operating hours: Increase the scheduled number of hours of operation by pressing  button, or reduce by pressing  button. See "Operating Time Table" for pool size and required operating hours. Press  button to select hours required, press  if too many hours were selected. The built-in timer will now operate for the number of hours selected at the same time each day.



(1 to 12 hours max per cycle)



NOTE: The Saltwater System will not operate if the filter pump is not operating.

4. Re-lock keypad controls: With the proper hour value showing, press and hold  button for 2 seconds until you hear a long "beep", then press and hold  button for another 2 seconds until you hear the second long "beep". A green LED light on the control panel will light up within a few minutes, which indicates the saltwater system starting chlorine production. With locking the control buttons into this setting you will have prevented unauthorized changing of the operating cycle.



NOTE: If you forget to Re-lock the keypad controls, the salt system will automatically lock the keypad controls and start working 1 minute later.

OPERATION INSTRUCTIONS (continued)

5. Operating hours can be re-adjusted if necessary. Follow steps 2 thru 4.
6. The scheduled operating hours displayed on the LED readout will decrease to zero as the unit operates. The LED shows "hours remaining" in the daily operating cycle.
7. The green LED light on the control panel will disappear when the cycle has ended. The system will go into a "Stand-By Mode" with the LED flashing "93". The system automatically goes into a "Power Saving Mode" and will automatically turn itself back on in 24 hours to continue its daily chlorine production.
8. The LED will become blank after 1 hour indicating the Saltwater System is dormant (Power Saving Mode) waiting for the next startup cycle to begin. Press any button ( or ) to view the last LED code.





SPECIAL NOTES

- Always use a test strip to test the chlorine level before entering or using the pool. If the chlorine level is too high, **wait until the chlorine level drops below 3 ppm before using the pool or operating the Saltwater System again.**
- **IMPORTANT: Never use the pool if chlorine level is more than 3 ppm. Do not operate Saltwater System while the pool is in use or occupied.**
- If a power outage occurs or the power cord is unplugged then the Saltwater System operating hours will have to be reset.



WARNING

Heavy pool usage, and higher temperatures may require higher chlorine output to maintain proper free available chlorine residuals.

ALARM CODES

No chlorine production will occur if “Low Water Flow”, “Low Salt Level” or “High Salt Level” are detected. If any of these conditions occur then the Saltwater System will sound an alarm that indicates chlorine production has stopped. A buzzer will sound and a Code (see below) will keep flashing on the LED for 1 hour. The buzzer and flashing light will end after one hour and the Saltwater System will go to Power Saving Mode. If this occurs then press any button ( or ) to view the code of the original problem so that it can be corrected.

Turn off the power of the unit and follow the solutions below to solve the problem. Turn on the unit again by following the “Operating Instructions”.

Code	Cause	Remedy	Flashing	Buzzer
 Low Water Flow or No Flow	1. Circulation line blocked.	<ul style="list-style-type: none"> Ensure the plunger valves are opened (if any). Ensure your filter cartridge, cell are clear from debris and dirt. See “Maintenance”. Release all trapped air in the circulation line. See Filter Pump Manual. 	Yes	Yes
	2. Incorrect inlet and outlet hose direction.	<ul style="list-style-type: none"> Check for the direction of water inlet and water outlet hose. Reverse the hoses if necessary. See “Set Up Instructions”. 		
	3. Scale on the flow sensor.	<ul style="list-style-type: none"> Ensure the flow sensor (especially the hinge) is clean. See “Maintenance”. 		
	4. Flow sensor cord is loose.	<ul style="list-style-type: none"> Check for flow sensor loose or not connected properly. Plug the flow sensor firmly into the flow sensor receptacle. 		
	5. Flow sensor failure.	<ul style="list-style-type: none"> Contact Intex Service Center for replacement. 		
 Low Salt Level	1. Dirt or scale on titanium plates.	<ul style="list-style-type: none"> Remove the electrolytic cell for inspection and clean it if necessary. See “Maintenance”. 	Yes	Yes
	2. Low salt level / No salt.	<ul style="list-style-type: none"> Add salt. See “Salt & Pool Water Volumes”. 		
	3. Possible electrolytic cell failure.	<ul style="list-style-type: none"> Contact Intex Service Center. Replace the cell if needed. 		
 High Salt Level	1. High salt level.	<ul style="list-style-type: none"> Partially drain the pool and refill with fresh water. See “Salt & Pool Water Volumes”. 	Yes	Yes

- The expected life expectancy of the electrolytic cell is 3,000 hours under normal use conditions.
- When replacing the cell, only use replacement cells having a label that clearly states that it is a replacement cell for the **Krystal Clear™ Deluxe Saltwater System (salt in pool) Model 8110**.

LED CODE CHART

LED CODE CHART

LED Reading	Definitions
88	Stand-By Mode (Start-up)
00	Zero Operating Hours
01	Minimum Operating Hour (1 hour remaining)
02	Operating Hours (2 hours remaining)
03	Operating Hours (3 hours remaining)
04	Operating Hours (4 hours remaining)
05	Operating Hours (5 hours remaining)
06	Operating Hours (6 hours remaining)
07	Operating Hours (7 hours remaining)
08	Operating Hours (8 hours remaining)
09	Operating Hours (9 hours remaining)
10	Operating Hours (10 hours remaining)
11	Operating Hours (11 hours remaining)
12	Maximum Operating Hours (12 hours remaining)
90	Alarm Code (Low Water Flow / No Flow)
91	Alarm Code (Low Salt Level)
92	Alarm Code (High Salt Level)
93	Stand-By Mode (Operating Process finished)
"BLANK"	No Power or "Power Saving Mode" waiting to start next Saltwater System cycle.

MAINTENANCE

IMPORTANT

Unplug power cord before cleaning and close plunger valves or insert black hat-like plugs in strainer opening to prevent water spillage. Plug in the power cord and open plunger valves or remove plugs when maintenance tasks are completed.

Flow Sensor Cleaning

1. In a counter-clockwise motion unscrew the collar of the flow sensor (7) and remove it from the flow sensor conduit (6). See "Part Reference".
2. If deposits and debris are seen on the surface of the flow sensor, then use a garden hose to wash it off.

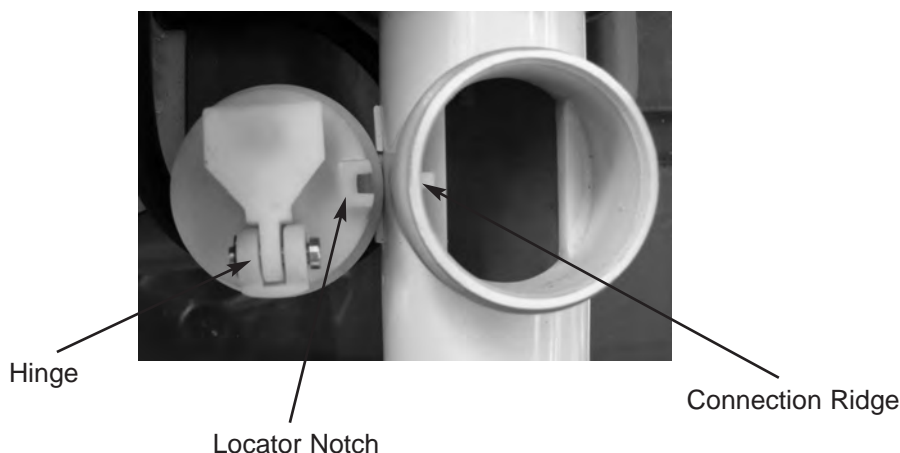

3. If flushing does not remove the deposits, use plastic brush (do not use a metal brush) to clean the surface and the hinge if necessary.
4. After the flow sensor has been inspected and cleaned, align the locator notch on the flow sensor to the connection ridge in the conduit, turn the collar in a clockwise motion tightening the sensor back into its position. Do not over tighten.

Electrolytic Cell Cleaning

The electrolytic cell (4) has a self cleaning function incorporated into the electronic control's programming. In most cases this self cleaning action will keep the cell working at optimum efficiency. If the pool water is hard (high mineral content) the cell may require periodic manual cleaning. Follow the cleaning instructions below. To maintain maximum performance, it is recommended that you open and visually inspect the electrolytic cell (4) every 3 months.

MAINTENANCE (continued)

Visual Inspection and Cleaning:

1. Switch off the unit, unplug the power cord from the electrical socket.
2. **For filter pumps with 32mm (1-1/4") hose size** - To prevent water from escaping the pool, unscrew the strainer grids from the strainer connectors and insert the hat-like plugs into the strainer connectors.
For filter pumps with 38mm (1-1/2") hose size - Grasp a plunger valve handle. Turn the handle counter-clockwise, push down until it stops and then turn it clockwise until the plastic protruding notch anchors in the "0/I" position. Repeat for the 2nd plunger valve. This prevents the water from flowing out of the pool.
3. Disconnect screen fitting (10) from the flow sensor conduit (6). See "Parts Reference".

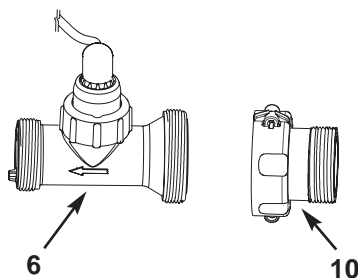

4. Disconnect the adaptor A from the Saltwater System outlet. Look inside the electrolytic cell (4) inspect for scale formation (light colored crusty or flaky deposits) on the titanium plates. If no deposits and debris are visible reinstall the adaptor A (1), and screen fitting (10).

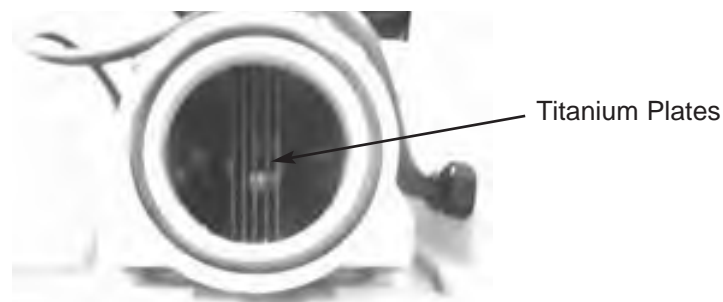

5. If deposits and debris are seen on the titanium plates, use a high pressure garden hose and try to flush them off. Only flush from the **direction of water inlet** to avoid damaging the flow sensor. Do **not** use any metal tool as this will scratch the coating off the plates. Note that a buildup on the cell indicates that there is an unusually high calcium level in the pool. If this is not corrected, you have to frequently check and clean the cell. To avoid this, always keep your pool chemistry at the recommended levels. See "Pool Maintenance & Chemical Definitions" for reference.

MAINTENANCE (continued)

6. If flushing does not remove the deposits on the plate then disconnect the cell from the base by removing the 4 mounting screws **(3)**. Disconnect the flow sensor from the top of the cell and unplug the electrolytic cell cord. Soak the cell in a vinegar solution (condiment) for 2-3 hours and then flush with high pressure water from the garden hose.
7. Reconnect electrolytic cell reversing steps 3, 4, 5 and 7. (Reset the Saltwater System's operating hours)

NOTE: After cleaning the operating hours have to be reset.

LONG TERM STORAGE

1. Disconnect power cord from electrical outlet.
2. After pool is emptied of all water, disconnect the Saltwater System from the hoses reversing the installation instructions.
3. Air-dry the unit before storage (It may be prudent to visually inspect and clean the electrolytic cell at this time).
4. Store the unit and accessories in a dry, temperature controlled, between 32 degrees Fahrenheit (0 degrees Celsius) and 104 degrees Fahrenheit (40 degrees Celsius) storage location.
5. The original packing carton can be used for storage.

INTEX® 3-WAY TEST STRIPS (PACKED WITH THE PRODUCT)

3-Way Test Strips can test the "Free Chlorine", "pH", and "Total Alkalinity" levels at the same time. Directions and Use:

1. Dip entire strip into water and remove immediately.
2. Hold strip level for 15 seconds (do not shake excess water from strip).
3. Compare free chlorine, pH and total alkalinity strip pad to the color chart on packaging label. Adjust pool water as necessary. Proper technique is important for water testing. Be sure to read and follow the written strip instructions.

POOL MAINTENANCE & CHEMICAL DEFINITIONS

Parameters	Recommended range
Free available chlorine	1.0 - 3.0 ppm
pH	7.2 - 7.8
Total alkalinity	100 - 120 ppm
Calcium hardness	200 - 300 ppm
Stabilizer (cyanuric acid)	30 - 100 ppm

Free Chlorine - Is the chlorine residual present in pool water.

pH - A value that indicates how acidic or basic a solution is.

Result if too low - Corroded metals, eye & skin irritation, destruction of total alkalinity.

Result if too high - Scale formation, cloudy water, shorter filter runs, eye & skin irritation, poor chlorine efficiency.

Total Alkalinity - Indicates the degree of the water's resistance to change in pH. It determines the speed and ease of pH change, so always adjust total alkalinity before adjusting the pH level.

Result if too low - Corroded metals, eye & skin irritation. Low alkalinity will cause the pH to be unstable. Any chemical added to the water will have an affect on pH.

Result if too high - Scale formation, cloudy water, eye & skin irritation, poor chlorine efficiency.



Calcium Hardness - Refers to the amount of calcium and magnesium dissolved in the water.

Result if too high - Scale will form and will cause the water to become cloudy.

Stabilizer (Cyanuric Acid) - Stabilizers extend the life of chlorine in swimming pools.

- DO NOT add pool chemicals directly to the skimmer. This may damage the cell.
- Maintaining high salt and chlorine levels above recommended range can contribute to corrosion of pool equipment.
- Check the expiry date of the test kit as test results may be inaccurate if used after that date.
- If additional chlorine is required due to heavy bather load, use a pool sanitizer based on Trichloro-s-triazinetrione or sodium dichloro-s-triazinetrione dihydrate.

TRUBLESHOOTING GUIDE

PROBLEM	CAUSE	REMEDY
INSUFFICIENT CHLORINE	<ul style="list-style-type: none"> • Insufficient operating hours of the Saltwater System. • Insufficient (Less than 2000 ppm) salt level in pool water. • Chlorine loss due to intense sunlight exposure. • The bather load has increased. • Clogged or dirty electrolytic cell. 	<ul style="list-style-type: none"> • Increase the Saltwater System operating time per day. See "Operating Instructions". • Test the Salt Level with Test Kit, and adjust as needed. See "Salt & Pool Water Volumes". • Use Pool Cover when the pool is not use and/or when the unit is operating. • Increase the Saltwater System operating time per day. See "Operating Instructions". • Remove the cell for inspection, clean it if necessary. See "Maintenance".
WHITE FLAKES IN THE WATER	<ul style="list-style-type: none"> • Excessive calcium hardness is present in pool water. 	<ul style="list-style-type: none"> • Drain about 20 to 25% of the pool water and add fresh water to decrease the calcium hardness. Visually inspect the electrolytic cell for scale build-up and clean the electrolytic cell if necessary.
NO LED DISPLAY	<ul style="list-style-type: none"> • Power Saving Mode. • No power supply. • Electrolytic cell cord is loose. • Power fuse blown. • LED failure. 	<ul style="list-style-type: none"> • Press any button ( or ) to view the last LED code. • Check for power cord loose or not connected properly. • Check to see if cell cord is loose or not connected properly. Ensure the cell cord is plugged firmly into the cell housing receptacle. • Contact Intex Service Center for replacement. • Contact Intex Service Center for replacement.

IMPORTANT

If you continue to experience difficulty, please contact our Consumer Service Department for assistance. See back cover for contact information.

TROUBLESHOOTING GUIDE (continued)

LED PANEL CODE	PROBLEM	REMED
LED Panel Code Flash & Alarm On (NOTE: Always turn off the power before cleaning and servicing).		
CODE 90	1. Circulation line is blocked.	<ul style="list-style-type: none"> • Ensure the plunger valves are opened (if any). • Ensure your filter cartridge and cell are clear from debris and dirt. See "Maintenance". • Release all trapped air in the circulation line. See Filter Pump Manual.
	2. Incorrect inlet and outlet hose direction.	<ul style="list-style-type: none"> • Check for the direction of water inlet and water outlet hose. Reverse the hoses if necessary. See "Set Up Instructions".
	3. Scale on the flow sensor.	<ul style="list-style-type: none"> • Ensure the flow sensor (especially the hinge) is clean. See "Maintenance".
	4. Flow sensor cord is loose.	<ul style="list-style-type: none"> • Check for flow sensor loose or not connected properly. Plug the flow sensor firmly into the flow sensor receptacle.
	5. Flow sensor failure.	<ul style="list-style-type: none"> • Contact Intex Service Center for replacement.
CODE 91	1. Dirt or scale on titanium plates.	<ul style="list-style-type: none"> • Remove the electrolytic cell for inspection and clean it if necessary. See "Maintenance".
	2. Low salt level / No salt.	<ul style="list-style-type: none"> • Add salt. See "Salt & Pool Water Volumes".
	3. Possible electrolytic cell failure.	<ul style="list-style-type: none"> • Contact Intex Service Center. Replace the cell if needed.
CODE 92	1. High salt level.	<ul style="list-style-type: none"> • Partially drain the pool and refill with fresh water. See "Salt & Pool Water Volumes".

GENERAL AQUATIC SAFETY

Water recreation is both fun and therapeutic. However, it involves inherent risks of injury and death. To reduce your risk of injury, read and follow all product, package and package insert warnings and instructions. Remember, however, that product warnings, instructions and safety guidelines cover some common risks of water recreation, but do not cover all instances or risk and or danger.

For additional safeguards, also familiarize yourself with the following general guidelines as well as guidelines provided by nationally recognized Safety Organizations:

- Demand constant supervision.
- Learn to swim.
- Take the time to learn CPR and first aid.
- Instruct anyone who is watching your children about potential pool hazards and about the use of protective devices such as locked doors, barriers, etc.
- Teach children what to do in case of an emergency.
- Always use common sense and good judgement when enjoying any water activity.
- Supervise, Supervise, Supervise.

For additional information on safety, please visit

- **The Association of Pool and Spa Professionals: The Sensible Way to Enjoy Your Aboveground/Onground Swimming Pool** www.nspi.org
- **American Academy of Pediatrics: Pool Safety for Children** www.aap.org
- **Red Cross** www.redcross.org
- **Safe Kids** www.safekids.org
- **Home Safety Council: Safety Guide** www.homesafetycouncil.org
- **Toy Industry Association: Toy Safety** www.toy-tia.org

SAFETY IN YOUR POOL

Safe swimming depends on constant attention to the rules. The "NO DIVING" sign within this manual can be posted near your pool to help keep everyone alert to the danger. You may also wish to copy and laminate the sign for protection from the elements.

LIMITED WARRANTY

Your **Krystal Clear™ Deluxe Saltwater System (salt in pool) Model 8110** has been manufactured using the highest quality materials and workmanship. All Intex products have been inspected and found free of defects prior to leaving the factory. This Limited Warranty applies only to the **Krystal Clear™ Deluxe Saltwater System (salt in pool) Model 8110**.

The provisions of this Limited Warranty apply only to the original purchaser and is not transferable. This Limited Warranty is valid for a period of two (2) years from the date of the initial retail purchase. Keep your original sales receipt with this manual, as proof of purchase will be required and must accompany warranty claims or the Limited Warranty is invalid.

If a manufacturing defect is found within this two (2) years period, please contact the appropriate Intex Service Center listed in this manual. The Service Center will determine the validity of the claim. If the Service Center directs you to return the product, please carefully package the product and send with shipping and insurance prepaid to the Service Center. Upon receipt of the returned product, the Intex Service Center will inspect the item and determine the validity of the claim. If the provisions of this warranty cover the item, the item will be repaired or replaced at no charge.

Any and all disputes regarding the provisions of this Limited Warranty shall be brought before an informal dispute settlement board and unless and until the provisions of these paragraphs are carried forth, no civil action may be instituted. The methods and procedures of this settlement board shall be subject to the rules and regulations set forth by the Federal Trade Commission (F.T.C.). IMPLIED WARRANTIES ARE LIMITED TO THE TERMS OF THIS WARRANTY AND IN NO EVENT SHALL INTEX, THEIR AUTHORIZED AGENTS OR EMPLOYEES BE LIABLE TO THE BUYER OR ANY OTHER PARTY FOR DIRECT OR CONSEQUENTIAL DAMAGES OR LIABILITIES. Some states, or jurisdictions do not allow the exclusion or limitation of incidental or consequential damages, so the above limitation or exclusion may not apply to you.

This Limited Warranty does not apply if the **Krystal Clear™ Deluxe Saltwater System (salt in pool) Model 8110** is subject to negligence, abnormal use or operation, accident, improper operation, improper voltage or current contrary to operating instructions, or to damage by circumstances beyond Intex's control, including but not limited to, ordinary wear and tear and damage caused by exposure to fire, flood, freezing, rain, or other external environmental forces. This Limited Warranty applies only to those parts and components sold by Intex. The Limited Warranty does not cover unauthorized alterations, repairs or disassembly by anyone other than Intex Service Center personnel.

DO NOT GO BACK TO THE PLACE OF PURCHASE FOR RETURN OR REPLACEMENT. IF YOU ARE MISSING PARTS OR NEED ASSISTANCE, PLEASE CALL US TOLL-FREE (FOR U.S. AND CANADIAN RESIDENTS): 1-800-234-6839.

Proof of Purchase must accompany all returns or the warranty claim will be invalid.

POST THIS WARNING NEAR YOUR POOL

! DANGER

**NO DIVING OR JUMPING
SHALLOW WATER**

DIVING MAY RESULT IN PERMANENT INJURY OR DEATH

- Be Safe. Swim with a friend.
- Children must be accompanied by an adult.
- Don't swim when using alcohol or drugs.
- Be familiar with the pool before swimming.
- No running, jumping, or horseplay in or around pool.
 - No glass in pool area.



TO AVOID SERIOUS INJURY ALL POOL USERS MUST KNOW AND FOLLOW THESE SAFETY RULES.

COUNTRIES/REGIONS

SERVICE CENTER LOCATIONS

- UNITED STATES
- CANADA

INTEX RECREATION CORP.
 14779 Bar Harbor Road
 Fontana, CA 92336
 Tel: 1-800-234-6839
 Fax: 310-549-2900
 Website: www.intexcorp.com (U.S./Canada only)
 Consumer Service Hours: 8:30 am to 5:00 pm
 Pacific Time, Mon. thru FRI. only.

- MEXICO

KAY INTERNACIONAL, S.A. DE C.V.
 Avenida San Jeronimo #550-5º Piso, Col.
 Jardines del Pedregal, C.P. 01900
 México D.F.
 Tel: 01-800-347-4020 (Collect Call)
 Tel: 55-9172-8035
 Fax: 55-9172-8047
 E-mail: servicenter@kayinternacional.com

- PANAMA
- PARAGUAY
- ECUADOR
- HONDURAS
- EL SALVADOR
- NICARAGUA

**SUPRO MUNDIAL S.A./
 PRODUCTOS SUPERIORES S.A.**
 Boulevard Andrews, Albrook,
 Panama, Rep. of Panama
 Tel: 507-315-0101
 Fax: 507-315-0114
 E-mail: suproadmin@supropanama.com

- COSTA RICA
- DOMINICAN REPUBLIC
- GUATEMALA
- COLOMBIA
- VENEZUELA
- PUERTO RICO

CENTURY USA, LLC
 4731 W. Atlantic Ave., Suite B-3
 Delray Beach, FL 33445, USA
 Tel: 561-495-0648
 Fax: 561-495-4782
 E-mail: sales@centuryusa.com

- MIDDLE EAST REGION

FIRST GROUP TRADING
 Al Moosa Group Building, 1st Floor,
 Office 102 & 103, UMM Hurair Road,
 Karama, Dubai, UAE
 Tel: 00971-4-3373322
 Fax: 00971-4-3375115
 E-mail: info@firstgrouptrading.com
 Website: www.firstgrouptrading.com

- ASIA

INTEX TRADING LTD.
 9th Floor,
 Dah Sing Financial Centre
 108 Gloucester Road,
 Wanchai, Hong Kong
 Tel: 852-28270000
 Fax: 852-23118200
 E-mail: xmservicesupport@intexcorp.com.cn
 Website: www.intexdevelopment.com

For answers to most frequently asked questions, please visit www.intexcorp.com.
 Non U.S. Residents, please visit www.intexdevelopment.com.

®

INTEX

For Residents of the U.S. & Canada:

INTEX RECREATION CORP.

Attn: Consumer Service

14779 Bar Harbor Road

Fontana, CA 92336

Phone: 1-800-234-6839

Fax: (310) 549-2900

Consumer Service Hours:

8:30 am to 5:00 pm Pacific time

Monday thru Friday only

Website: www.intexcorp.com

For Residents outside of the U.S. and Canada:

Please refer to the Service Center Locations

©2007 Intex Marketing Ltd. - Intex Trading Ltd. - Intex Recreation Corp.

All rights reserved/Tous droits réservés/Todos los derechos reservados/Alle Rechte vorbehalten.

Printed in China/Imprimé en Chine/Impreso en China/Gedruckt in China.

®™ Trademarks used in some countries of the world under license from/®™ Marques utilisées dans certains pays sous licence de/Marcas registradas utilizadas en algunos países del mundo bajo licencia de/Warenzeichen verwendet in einigen Ländern der Welt in Lizenz von/Intex Marketing Ltd. to/à/a/an Intex Trading Ltd., 9th Floor, Dah Sing Financial Centre, 108 Gloucester Road, Wanchai, Hong Kong & Intex Recreation Corp., P.O. Box 1440, Long Beach, CA 90801 • Distributed in the European Union by/Distribué dans l'Union Européenne par/Distribuido en la unión Europea por/Vertrieb in der Europäischen Union durch/Intex Trading B.V., P.O. Box nr. 1075 - 4700 BB Roosendaal - The Netherlands

 **INTEX®**

This label transcript service is offered by the Pest Management Regulatory Agency to provide efficient searching for label information. This service and this information do not replace the official hard-copy label. The PMRA does not provide any guarantee or assurance that the information obtained through this service is accurate, current or correct, and is therefore not liable for any loss resulting, directly or indirectly, from reliance upon this service.