

(ELECTRODE LABEL)

DUOCLEAR 200 REPLACEMENT ELECTRODE

To be used with DuoClear 200 Chlorine Generating System.

Replacement electrode for the DuoClear 200 Chlorine Generating System.
REGISTRATION NUMBER 28212, PEST CONTROL PRODUCTS ACT.
This electrode must only be used on this model of chlorine generating device.

READ THE LABEL AND REFER TO OWNER'S MANUAL BEFORE USING.

KEEP OUT OF REACH OF CHILDREN.

ZODIAC POOL SYSTEMS CANADA INC.
2115 SOUTH SERVICE ROAD WEST, UNIT 3
OAKVILLE, ONTARIO L6L 5W2
CANADA
1-888-647-4004

(DUOCLEAR 200 DEVICE LABEL)

DUOCLEAR 200 CHLORINE GENERATING SYSTEM

DOMESTIC
REGISTRATION NO. 28212
PEST CONTROL PRODUCTS ACT

READ THE LABEL AND REFER TO THE OWNER'S MANUAL BEFORE USING.

Controls bacteria and algae in swimming pool waters. The DuoClear System consists of Nature2 Technology used in conjunction with the chlorine generating device. The Nature2 cartridge augments the bactericidal and algicidal activity of the primary disinfectant, chlorine.

The DuoClear system contains a power pack and an electrode. The mineral cartridge is sold separately.

Maximum output of hypochlorous acid equivalent to 0.816 kg of free available chlorine per day.

One DuoClear 200 can treat a maximum of 200,000 litres of swimming pool water.

For swimming pools, the recommended level of free available chlorine is 1-3 ppm. This level may be lowered to 0.6 ppm, but not below, with the use of Nature2 cartridges.

WARNING: Operating the DuoClear system without water flow through the vessel can cause a build up of flammable gases which can result in FIRE OR EXPLOSION.

KEEP OUT OF REACH OF CHILDREN

WARNING: Staining of pool surfaces may occur due to deposits of copper salts. Excessive levels of copper will increase the probability of this occurrence.

FIRST AID: If swallowed: Call a poison control centre or doctor immediately for treatment advice. Have person sip a glass of water if able to swallow. Do not induce vomiting unless told to do so by a poison control centre or doctor. Do not give anything by mouth to an unconscious person.

Take label or product name and PCP Registration Number with you when seeking medical attention.

ZODIAC POOL SYSTEMS CANADA INC.
2115 SOUTH SERVICE ROAD WEST, UNIT 3
OAKVILLE, ONTARIO L6L 5W2
CANADA
1-888-647-4004

(CARTRIDGE LABEL)

DUOCLEAR 200 MINERAL CARTRIDGE
FEATURING NATURE2 TECHNOLOGY

DOMESTIC
REGISTRATION NO. 28212
PEST CONTROL PRODUCTS ACT

To be used with DuoClear 200 Chlorine Generating System.

READ LABEL AND REFER TO OWNER'S MANUAL BEFORE USING.

KEEP OUT OF REACH OF CHILDREN.

The DuoClear System consists of Nature2 Technology used in conjunction with a chlorine generating device. The Mineral Cartridge augments the bactericidal and algicidal activity of the primary disinfectant, chlorine.

WARNING: Staining of pool surfaces may occur due to deposits of copper salts. Excessive levels of copper will increase the probability of this occurrence.

PRECAUTIONS: Hazards to Humans and Domestic Animals. In the unlikely event that a cartridge breaks, mineral media should not be ingested by humans or animals as it may cause gastric distress.

FIRST AID: If swallowed: Call a poison control centre or doctor immediately for treatment advice. Have person sip a glass of water if able to swallow. Do not induce vomiting unless told to do so by a poison control centre or doctor. Do not give anything by mouth to an unconscious person.

Take container label or product name and PCP Registration Number with you when seeking medical attention.

ZODIAC POOL SYSTEMS CANADA INC.
2115 SOUTH SERVICE ROAD WEST, UNIT 3
OAKVILLE, ONTARIO L6L 5W2
CANADA
1-888-647-4004

(OPERATION MANUAL)

**ZODIAC DUOCLEAR 200
CHLORINE GENERATING SYSTEM
FOR RESIDENTIAL INGROUND POOLS
DOMESTIC
REGISTRATION NUMBER 28212
PEST CONTROL PRODUCTS ACT**



INSTALLATION AND OPERATOR'S MANUAL

**TO THE BUILDER: PLEASE LEAVE THIS MANUAL WITH POOL OWNER
TO THE POOL OWNER: PLEASE SAVE THIS MANUAL**

**PLEASE READ THE LABEL, INSTALLATION AND OPERATION MANUAL BEFORE USING.
KEEP OUT OF REACH OF CHILDREN**

**PLEASE READ THE LABEL, INSTALLATION AND OPERATION MANUAL BEFORE USING.
PLEASE KEEP YOUR OPERATION MANUAL AS IT CONTAINS YOUR WARRANTY.**

**THE DUOCLEAR SYSTEM CONTAINS A POWER PACK AND AN ELECTRODE. THE NATURE²
CARTRIDGE IS SOLD SEPARATELY.**

Controls bacteria and algae in swimming pool waters.

For swimming pools, a minimum of 0.6 ppm of free available chlorine must be maintained. The Nature² cartridge augments bactericidal and algicidal activity of the primary disinfectant, chlorine.

Maximum output of hypochlorous acid equivalent to 0.816 kg of free available chlorine per day.

One DuoClear 200 can treat an outdoor swimming pool to a maximum of 200,000 litres.

THE DUOCLEAR CHLORINE GENERATING SYSTEM HAS BEEN TESTED AND APPROVED TO
CAN/CSA C22.2 (NO. 218.1)

DOMESTIC
REGISTRATION NUMBER: 28212
PEST CONTROL PRODUCTS ACT

Congratulations on your purchase of the Zodiac DuoClear Chlorine Generating System. You have made a wise decision and you will benefit from your DuoClear for many years to come.

Please take a moment to read through the entire manual before installing your new system. The chlorinator must be installed and operated as specified.

**ZODIAC POOL GROUP CANADA INC.
2115 SOUTH SERVICE ROAD WEST, UNIT 3
OAKVILLE, ON L6L 5W2
CANADA
1-888-647-4004**

TABLE OF CONTENTS

	Page
Safety Precautions	4
DuoClear Product Specifications	7
DuoClear Installation Instructions.....	8
How Your DuoClear Works	10
Features of the DuoClear System	10
DuoClear Start up Process	12
Using the Control Panel Operating Functions	13
DuoClear Cartridge and Electrode Life	14
DuoClear Maintenance	14
Operating Hints	16
Salt: When & How To Add	17
Salt Chart	18
Stabilizer Chart	18
Some Tips On Water Chemistry.....	19
Winterizing Your Pool	20
Troubleshooting	21
Warranty Information.....	25

SAFETY PRECAUTIONS

**IMPORTANT SAFETY INSTRUCTIONS. READ AND FOLLOW ALL INSTRUCTIONS.
SAVE ALL INSTRUCTIONS.**

KEEP OUT OF REACH OF CHILDREN

Hazard to humans and domestic animals. In the unlikely event that a cartridge breaks, mineral media should not be ingested by humans or animals as it may cause gastric distress.

FIRST AID: If swallowed: Call a poison control centre or doctor immediately for treatment advice. Have person sip a glass of water if able to swallow. Do not induce vomiting unless told to do so by a poison control centre or doctor. Do not give anything by mouth to an unconscious person.

Take container label or product name and PCP Registration Number with you when seeking medical attention.

When installing and using this electrical equipment, basic safety precautions should always be followed, including the following:

- Service should only be attempted by a qualified pool professional.
- Disconnect all AC power during installation
- Connect to a circuit that is protected by a ground fault circuit interrupter. (GFCI)
- Do not operate the DuoClear system without water circulation.
- Power supply must be synchronized with the pool pump motor power source or automatic timer.

WARNING: Failure to heed the following warnings can result in permanent injury, electrocution or drowning.

Electrical Hazard

- To reduce risk of electrical shock
 - Make sure all power to pool equipment area is off prior to any installation or removal of DuoClear system components.
 - Replace damaged power pack cord immediately.
 - Do not bury cord. Locate cord to minimize abuse from lawn mowers, hedge trimmers and other equipment.
- Install the power pack at least 3.05 metres (10 feet) from the inside walls of a pool to prevent any possibility of the unit coming in contact with water.
- Your DuoClear system has been designed with an electronic flow sensor. This device automatically switches the chlorinator 'OFF' when the water through the cell stops. To prevent vessel damage and personal injury, do not in any way interfere with this system which has been designed for your protection.

Chemical use Hazard

- To avoid personal injury when working with pool chemicals, always wear rubber gloves and eye protection and work in a well-ventilated area. Use caution when choosing a location to open and use chemicals as they may damage any surface in which they come in contact.
- The addition of certain chemicals can reduce the effectiveness of chlorine. Always make sure that proper residual chlorine levels are maintained to avoid personal injury.
- This product manufactures chlorine. Individuals with any type of chlorine sensitivity should take the appropriate precautions to avoid injury or illness.

Equipment Water Pressure Hazard

- Always turn pump off prior to installing or removing or opening any part of the DuoClear system. Your pump/filter system is operated under pressure and the pressure must be released before you begin work. Please see your pump/filter owner's manual for further instructions.
- To avoid vessel damage, water pressure in vessel must not exceed 225 kPa (45 psi).

Prevent Child Injury and Drowning

- To reduce the risk of injury, do not permit children to operate or perform maintenance on this product.
- Do not let anyone, especially small children, sit, step, lean, or climb on any equipment installed as part of your pool's operational system. Unless otherwise stated, ALL components of your pool's operational system should be located at least 1 metre (3 feet) from the pool so children cannot use the equipment to gain access and be injured or drown.

WARNING: Failure to heed the following warnings could cause damage to pool equipment or personal injury.

- Chlorinator must be installed and operated as specified.
- Scratching or bending plates in cell housing can reduce cell life.
- Power to the DuoClear system should be turned off before unplugging the vessel connectors to prevent cell damage and low voltage sparks.
- Keep the electrode terminals protected with a light coating of silicone grease to allow for a positive electric connection. Use of any other type of grease may damage the terminal seals and o-rings. Do not immerse these terminals in acid wash solution, and avoid accidental contact with salt water.
- Water above the temperature of 40 degrees C (104 degrees F) flowing through the vessel can cause plastic vessel to discolour.
- Power pack must not be installed directly above any other heat source such as filter, pump or heater. It must be at least 30 cm (1 foot) from the ground to allow free circulation of air around it. It must not be installed in a closed box. If the power pack is to be installed on a post, then it must be centrally positioned on a flat panel of suitable waterproof material at least 36 cm wide x 33 cm high (14" x 13").
- Check the cell frequently to prevent the accumulation of pool debris that for any reason may have bypassed the pool filter.
- Turn device off when backwashing the filter.

ZODIAC, MASTERING THE ELEMENTS

Renowned worldwide for the quality and reliability of its products in the aeronautical and marine sectors, Zodiac has now brought its expertise to swimming pools, to bring you a full range of pools, automatic pool cleaners and water treatment systems.

Backed by Nature2® and Clearwater® technology, expertise and experience, Zodiac brings you the reassurance of top quality equipment in terms of both design and performance. A real guarantee of efficiency and peace of mind!

Dear Pool Owner,

Congratulations on purchasing a Zodiac DuoClear™ Chlorine Generating System. DuoClear will help you and your family to benefit from greater enjoyment of your pool. There are two major advantages in owning a DuoClear system. First you will find that the pool will be easier to maintain, secondly you will notice the clarity and feel the softness of the water.

Please take the time to read through your DuoClear Owner's Manual. It is set out in such a way that you can see the simple steps to keep your pool in pristine condition.

This owner's manual will provide you with useful information on how to operate the DuoClear system most efficiently and help you to understand more about the maintenance of your pool. Your local pool shop can also be helpful in a more detailed explanation of the care of your pool and assist you with any questions or problems.

Don't forget that your DuoClear system is backed by a comprehensive warranty. The DuoClear warranty is an expression of the confidence that Zodiac Pool Systems Canada Inc. has in its products, and is your assurance of prompt and expert after-sales service by professional technicians. If you require any additional information talk to your pool professional, or telephone Zodiac Pool Systems Canada Inc. at 1-888-647-4004.

DUOCLEAR™ PRODUCT SPECIFICATIONS

Model: DuoClear 200

Salt Level	4 000 ppm
Power Requirements	220 V – 240 V, 60 Hz, 2 amp draw
Power Output	27 V, 4.5 amp DC
Power Consumption	130 W
Minimum Flow Rate	45 litres per minute (12 gallons per minute)
Plumbing	5 cm (2") Schedule 40 PVC
Maximum water temperature	40°C (104°F)
Maximum operating pressure	225 kPa (45 psi)
Vessel Dimensions	28 cm x 15 cm x 28 cm (11" x 6" x 11")
Power pack dimensions	29 cm x 9.5 cm x 25.4 cm (11 ½" x 3 ¾" x 10")

Nature² Cartridge warranty: 6 months

Power pack, vessel, and electrode warranty: 3 years limited, not pro-rated

The DuoClear system is for residential pools only.

Important: When converting a bromine treated pool to the DuoClear System, the pool must be completely drained and refilled.

Maintaining constantly high levels of salt and chlorine above recommended levels may contribute to corrosion of the pool equipment.

INSTALLATION INSTRUCTIONS

1. Salt

Use refined pure salt (sodium chloride) and avoid additives such as iodine. Add salt at the rate of 4 kg per 1000 litres to raise the salt level from 0 to 4000 ppm. For existing pools with a residual of sodium chloride from chlorine use, determine the current level of salt in the pool then add enough salt to raise the level to 4000 ppm. 1 gram per litre (or 1 kg per 1000 litres) raises the salt level 1000 ppm. Refer to Salt Chart for further detail.

Distribute the salt evenly at various positions in the pool. Do not pour into skimmer box. The pump may be turned on to circulate the water and help the salt dissolve. **Note:** do not operate the DuoClear before the salt has dissolved as this will cause damage to the unit. After all the salt has dissolved, set the chlorine output control to maximum. If the output light reaches the maximum level, the salt level is correct.

Note that the chlorinator output depends on salt concentration, water temperature, and mains power voltage. The nominal standard values of 4000 ppm salt, 27 °C (80° F) water temperature, and correct mains voltage, will provide maximum output. If any one or more of these three variables are less than the standard values, the output may be less.

2. Plumbing the DuoClear Vessel

It is very important that the vessel is the last piece of equipment before the pool. If it is not, the chlorine may corrode other equipment. It is also extremely unsafe for the gases produced by the chlorinator to travel through a filter or heater.

The vessel must be plumbed level, ports facing downward. The vessel must be level in order for the flow sensor to function properly. The vessel must be located within 1.8 metres (6 feet) of the power pack. There are no height restrictions or requirements.

It can only be plumbed one way. The inlet and outlet are labelled. (The inlet side is the side with the DuoClear Nature2 cartridge, the outlet side is the side with the chlorinating electrode.)

The ports in the bottom of the sanitizing system are 5.1 cm (2 inch) slip ports. PVC reducing bushings may be used to reduce the port size. Any standard PVC cement may be used. Allow adequate drying time before pressurizing the system.

DO NOT INSTALL AN ISOLATION VALVE ON THE DISCHARGE SIDE OF THE SANITIZING SYSTEM. If a valve is required, due to a flooded plumbing situation, use a one-way check valve. If the sanitizer is plumbed on by-pass, install the isolation valve on the inlet side only.

The DuoClear Sanitizing System is available in three different sizes to sanitize pools up to 200,000 litres. Do not use multiple units in one pool.

3. Installing the Power Pack

The power pack must be located a minimum of 3.05 metres (10 feet) from the inside wall of the pool. Use the anchors provided to mount the bracket onto the wall. If the power pack is to be mounted onto a post, a waterproof backing of at least 35.6 cm wide x 33 cm high (14" x 13") must be used. Do not enclose the power pack in any box. Do not install it above any heat source. Hang the power pack on the bracket. If wiring to a controller, consult the controller manual for additional instructions.

The power pack is 220-240 VAC ONLY. It wires to the load side of a pool timer or the pump circuit of a controller so that when the pool pump comes on the DuoClear system comes on. The green ground wire must be attached to the grounding screw or grounding bar. Follow all aspects of the local and National Electrical Code(s) when installing the DuoClear chlorine generating device.

Apply a light coating of silicone grease to the electrode plug to allow for a positive electric connection. Connect the power pack to the electrode by pressing the yellow electrode plug firmly onto the electrode connectors. Use of any other type of grease may damage the terminal seals.

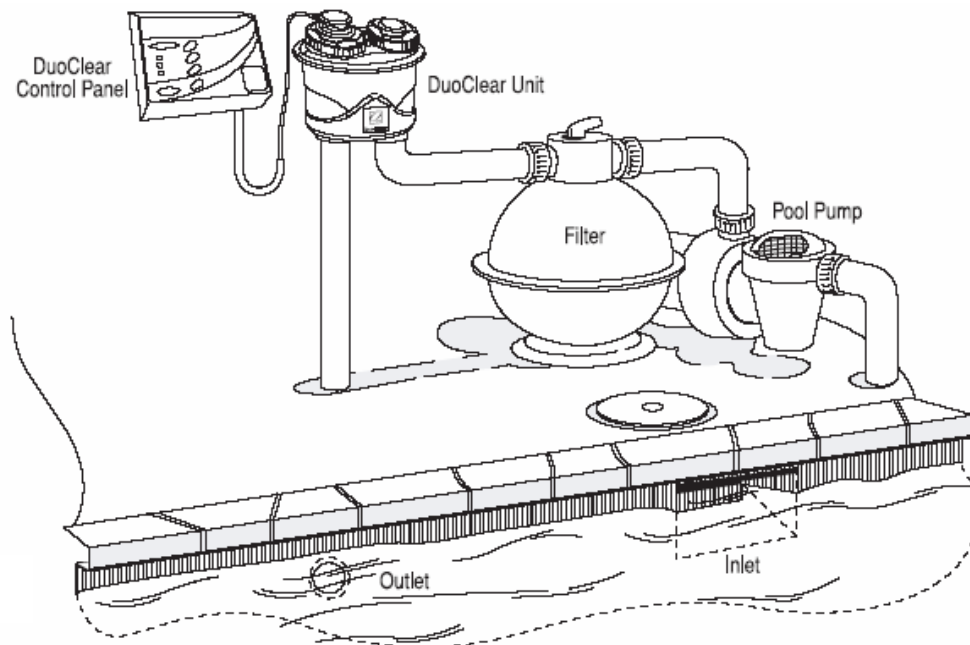

HOW YOUR DUOCLEAR WORKS

Common salt (sodium chloride) is made up of two elements, sodium and chloride. A controlled quantity of salt is dissolved in the pool water to make it slightly salty. As the salty water is passed through the DuoClear system by the filtration system, the process of electrolysis occurs and chlorine is produced, which is dissolved instantly into the water.

The chlorine controls bacteria and works together with the copper from the Nature2 cartridge to control algae. In doing this, the chlorine reverts back to the dissolved salt ion, chloride, and the process is repeated.

IMPORTANT: To ensure your DuoClear system works at maximum efficiency, regularly check and maintain the water chemistry of your pool.

Water Chemistry Readings

Maintain daily levels as determined by test kit

Ideal salt concentration:	4,000 ppm
Free chlorine:	1.0 – 3.0 ppm. This level may be lowered to 0.6 ppm with the use of the Nature2 cartridge.
pH:	7.2 to 7.8
Total alkalinity:	100 to 120 ppm
Calcium hardness:	200 to 300 ppm
Chlorine stabilizer (Cyanuric acid):	30 to 100 ppm (NOTE: indoor pools do not require chlorine stabilizer)

Note: If you are using a home test kit, check the expiry date of the test kit as results may be inaccurate if used after that date.

FEATURES OF THE DUOCLEAR SYSTEM

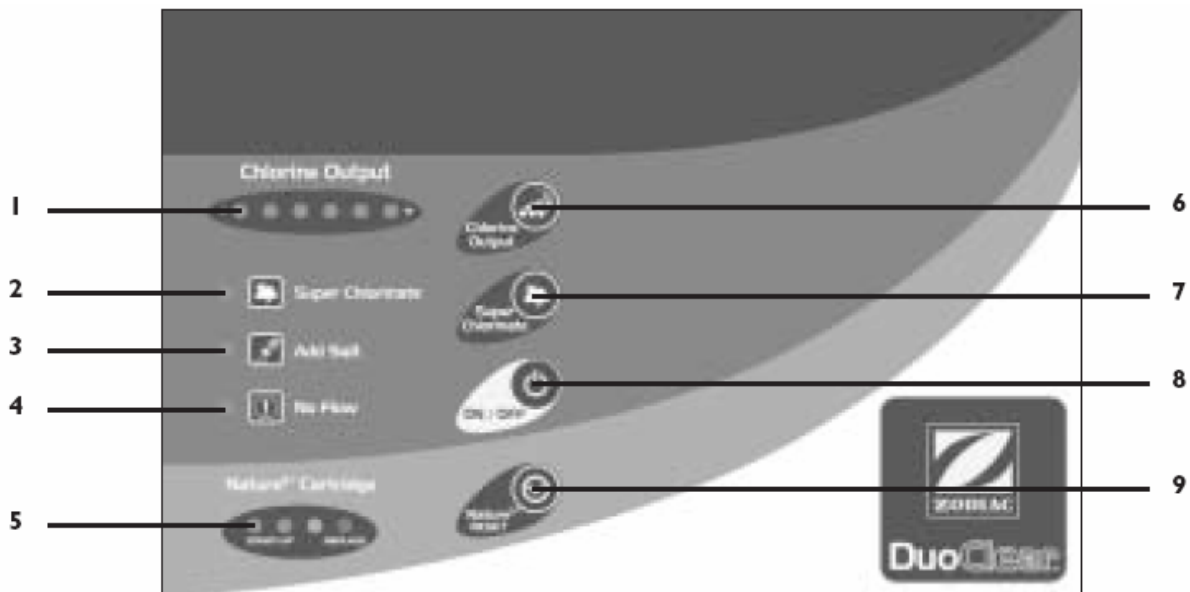

The “**Chlorine Output**” (6) controls the amount of chlorine generated by the electrode. Next to it are 6 indicator lights, (See power panel illustration above) 1 yellow (minimum output) and 5 green indicator lights (1). Maximum chlorine output is achieved when all lights are on.

Activating the “**Super Chlorinate**” (7) function increases the chlorine output beyond the “6 lights on” level, for the next 24 hours of active running time. This is used when the pool needs extra sanitation after heavy rain, hot weather or heavy bather loads.

The adjacent green indicator light (2) will be on when this function is operating.

“**Add Salt**” (3) indicator – green light will change to yellow when more salt is needed.

“**No Flow**” (4) indicator – red light – This indicates insufficient water flow through the vessel, usually caused by the pump not running. Chlorine production is stopped until proper flow is resumed

“**ON/OFF**” (8) button switches the DuoClear system ON and OFF. The back-up battery will keep memory of the last output setting and resume this setting once the power is turned back on. As a safety precaution, the DuoClear will automatically power on when the next pump cycle starts. In order to avoid this, disconnect the electrode plug to the power pack.

The “**Nature2 Reset**” (9) button is used only at start-up of your new system and each time the Nature2 cartridge is replaced.

Backup Battery

DuoClear is fitted with a long life rechargeable battery. If the power is removed, it will retain the output power settings, Super Chlorinate settings, and the Nature2 indicator settings.

DuoClear is designed to require minimum operator maintenance once it is set.

The polarity of the electrodes periodically reverses in order to minimize scaling on the electrode plates. This reduces manual cleaning time however, depending on the pool water chemistry, you may need to clean the electrode plates occasionally.

Power to the unit is controlled by your pool timer or a controller. This ensures that the DuoClear will only function while water is flowing through the vessel.

The chlorinator functions may only be set while the filtration system is operating.

In order to use the Super Chlorinate mode effectively, the pool filtration system should be run continuously for 24 hours.

DUOCLEAR START UP PROCESS

Before starting up the DuoClear system you must add the required amount of salt for your size pool. (Refer to Salt Chart on page 18). Also, clean any debris and algae out of the pool and pool equipment.

NOTE: We recommend waiting 2-4 weeks before adding salt to a newly plastered pool.

Important: Do not start the DuoClear system until the pool water is chemically balanced. See Water Chemistry Readings on page 10.

1. Install the cartridge after the water is balanced.
2. Shock the pool water with chlorine according to manufacturer's instructions to burn off contaminants and activate the cartridge.
Note: This is not the same as the "Superchlorinate" feature on the DuoClear system. A manual shock treatment is required at start-up to activate the cartridge.
3. Press the "**Nature2 Reset**" button to start the cartridge timer, which will count down 6 months to the next cartridge change.
4. Run the circulating pump either
24 hours a day for 4 days, or
6 hours a day for 14 days, while maintaining 1-3 ppm of free available chlorine
5. Let chlorine gradually dissipate to 0.6 ppm once the circulating period is completed.

NOTE: If the temperature is below 18°C (65°F) you may not be able to set the output to maximum because of a slight reduction of conductivity in colder temperatures (the Add Salt light may also come on). When the water is below 18°C (65°F), there is very little algae growth and it is too cold for swimming so the chlorine does not get used up as much as it would during normal operating conditions. If this is the case, you can leave the DuoClear at a lower output setting until the temperature warms up.

WARNING: Never allow the concentration of free chlorine to go below 0.6 ppm. If this is not possible with the DuoClear system, use a manual application of liquid chlorine (sodium hypchlorite).

SAFETY TEST

It is essential that the flow failure system be tested by the following method. Switch on the pump and DuoClear, and adjust the chlorine output to maximum. Disconnect the yellow electrode plug from the terminals at the top of the electrode cell. The red 'Low Flow' light should come on and the 'Chlorine Output' lights will drop to minimum, yellow light, showing that no chlorine is being produced.

This check should confirm that the flow failure system is operating correctly.

Reconnect the electrode plug to the terminals which will cause the chlorinator to resume normal operation. Do not continue to operate the chlorinator if the test of the flow failure system indicates a fault. Contact Zodiac Pool Systems Canada Inc. for advice.

USING THE CONTROL PANEL OPERATING FUNCTIONS

Setting the “Chlorine Output” (See #1 on control panel illustration)

Chlorine production is controlled by both the number of hours your pool pump runs and by controlling the “Chlorine Output” (1). Repeated pushing of the “Chlorine Output” (6) button increases the chlorine production one step at a time and the number of “Chlorine Output” indicator lights showing, until maximum is reached (one yellow and five green lights). An extra push of the “Chlorine Output” button resets the output to minimum – one yellow light.

NOTE: This setting does not show the actual chlorine reading in the pool. Use of a test kit is required to confirm the Free Chlorine reading of the pool water. (Or take a water sample to your pool shop for testing.)

During polarity reversal the yellow light flashes. The yellow (minimum output) light will flash for a few minutes when the electrode polarity reverses (Self cleaning function) indicating no output during this time.

“Super Chlorinate” (2)

The Super Chlorinate (2) function is used to boost chlorine output to the pool.

When pressed, the chlorine output settings are temporarily over-ridden and the chlorinator is set to run for approximately 24 hours at increased chlorine production.

A green light will indicate this is functioning. To disable, press the Super Chlorinate

(7) button a second time and the light will go off. Previous output settings will resume at the conclusion of the Super Chlorinate period. (See Troubleshooting parts B & C for details regarding when the Super Chlorinate function should be used.)

“Add Salt” (3)

The “Add Salt” light may come on at any salt level between 3000 ppm and 4000 ppm depending on mains voltage and water temperature. This is not a fault but a precaution to ensure the salt level is never too low. (See “Salt: When And How To Add It”.)

NOTE: Operating the DuoClear system at reduced salt levels may shorten the life of the electrode.

“No Flow” (4)

The “No Flow” light will come on if there is insufficient water flow in the cell, usually caused by the pump not running or the filter needing to be cleaned. The “Chlorine Output” function will turn off at this time. (See “Troubleshooting”.) The green “Chlorine Output” indicator lights will also turn off at this time.

“DuoClear Nature2 Cartridge” Indicator Lights (5)

A series of 4 lights indicate life of the DuoClear Nature2 Cartridge. When the DuoClear Nature2 Cartridge is first installed and started the “Reset” (9) button should be pressed and the Nature2 Cartridge (5) will display 3 indicator lights – 2 green, 1 yellow. As the timer counts down, the 2 green lights, then the yellow light will progressively go out to bring a red light on and flashing. This indicates the DuoClear Nature2 cartridge needs to be replaced. The DuoClear Nature2 cartridge has a six month life.

All Lights OFF

If all the lights are OFF it indicates that the DuoClear system is turned off. Check to see if the pool time clock is ON or OFF, or if the mains power is disconnected.

DUOCLEAR CARTRIDGE AND ELECTRODE LIFE

The system has a set of four lights which indicate the life of the DuoClear Nature2 cartridge. The “Start up” lights are 2 green and 1 yellow. Over six months the 2 green lights and yellow light gradually go out, and then a red light begins to flash. When this red light flashes you must replace the DuoClear Nature2 cartridge. **If the cartridge is not replaced promptly, the pool will not be sanitized properly at a concentration of less than 1.0 ppm of free chlorine.**

The expected lifespan of the electrode when sized and maintained appropriately is approximately 5 years in a seasonal climate. However in conditions where there is a high demand for chlorine (high bather load, poor water chemistry, very hot climate) this lifespan may be reduced.

When replacing the cartridge or electrode, only use replacements having a label that clearly states that it is a replacement for the DuoClear Chlorine Generating System, and that the model name matches that of the vessel and power pack. The model name can be found on the front of the power pack.

DUOCLEAR™ MAINTENANCE

Replacing the DuoClear Cartridge

A DuoClear cartridge lasts six months under normal operating conditions and should be replaced as soon as the DuoClear Nature2 Cartridge life indicator light turns RED and flashes.

NOTE: Always turn pump off prior to installing, removing or opening the DuoClear system. Your pump/filter system is operated under pressure and pressure must be released before you begin. Open the air relief valve on your pool filter to release the pressure in the system.

To replace the cartridge:

1. Turn off the pool pump and release the pressure in the system.
2. If appropriate, close any valves between the filter and pool to prevent draining the pool.
3. Unscrew the cartridge locking ring and remove the cartridge.
4. Install the new cartridge and insure the O-ring is seated and lightly coated with silicone lubricant. Tighten the cartridge locking ring.
5. Press the “Nature2 Reset” button (9) on the power pack so that the three indicator lights (5) (2 green and 1 yellow) are on.
6. Open any valves that were closed to isolate the DuoClear vessel.
7. Restart your pool’s pump and filtration system. Check for leaks.
8. Follow the DuoClear cartridge start up procedures on page 12.

NOTE: A concentration of less than 1.0 ppm of free available chlorine residual is not sufficient if the DuoClear system is operated without replacing the DuoClear Nature2 cartridge.

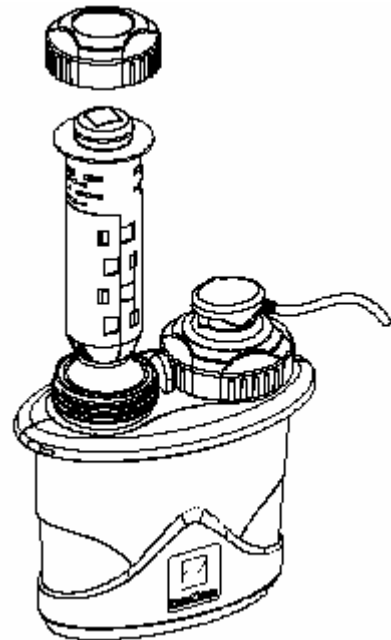

How to clean the electrode

Depending upon water chemistry, occasional manual electrode cleaning may be necessary.

1. Switch off the filter pump and chlorinator, close necessary valves.
NOTE: Always turn pump off prior to installing or removing any part of the DuoClear system. Your pump/filter system is operated under pressure and pressure must be released before you begin. Open the air relief valve on your pool filter to release the pressure in the system.

2. Unplug the electrode plug from the vessel.
3. Unscrew the electrode retaining ring and remove the electrode.
4. Look down into the electrode bundle to see if there is scale on the plates.

NOTE: To avoid personal injury when working with pool chemicals, always wear rubber gloves and eye protection and work in a well ventilated area. Use caution when choosing a location to open and use chemicals as they may damage any surface into which they come in contact.

5. Mix cleaning solution in a suitable plastic vessel by adding one (1) part of Hydrochloric (muriatic) acid to ten (10) parts water.
NOTE: To avoid splash, always ADD MURIATIC ACID TO WATER rather than water to muriatic acid. Solutions stronger than 1:10 will damage electrode and void warranty. Submerge only the plates of the electrode in the cleaning solution. Allow the cleaning solution to dissolve the calcium deposits for approximately 5 minutes.
6. Repeat the procedure if necessary. Take care to avoid splashing the electrode terminals and other equipment with the acidic cleaning solution. Wash down any spills with plenty of fresh water. To neutralize acid cleaning solution, add baking soda (foaming will occur).
7. Rinse the electrode in clean water and reinstall the electrode into the vessel. Insure the O-ring is seated properly and coated lightly with silicone lubricant.
8. Replace the electrode plug after drying and smearing lightly with silicone grease.
9. Reset valves and switches. Turn pump and chlorinator on.
10. Confirm chlorine output and settings on the power pack.

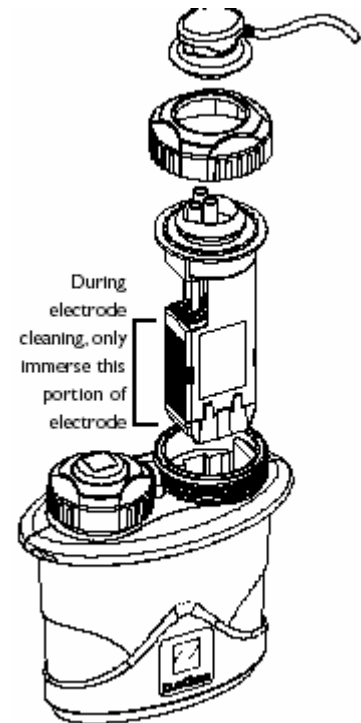

Your DuoClear system has been designed with an electronic flow sensor. This device automatically switches the chlorinator "OFF" when water flow through the electrode plates stops or slows down. To prevent electrode damage and personal injury, do not in any way interfere with this system that has been designed for your protection.

OPERATING HINTS

A. Filtration and chlorination system operating periods

Run your filtration and chlorination system for at least 6 to 8 hours per day in the swimming season. During very hot weather it might be necessary to run the system for additional hours, but in winter where pools remain open, the filtration system may be run over a shorter period of time. Shorter run periods will help to lengthen the life of the electrode.

B. Free (residual) chlorine reading

The free chlorine residual in the pool must be 0.6 – 3.0 ppm. Increasing the daily operating period of the system increases the free chlorine reading, and a shorter operating period reduces the chlorine reading. Likewise, operating the system at maximum output will produce a higher chlorine reading than operating at a lower setting.

C. Chlorine stabilizer (Cyanuric acid) level

Make sure that the water has a satisfactory level of chlorine stabilizer (Cyanuric acid) reading between 30 – 100 ppm. This will vary depending on your regional climate. Extremely hot and sunny climates will require readings at the higher end on the given range. Refer to the Stabilizer Chart. Cyanuric acid prevents rapid destruction of chlorine by the sun's rays. Regulations may exist regarding the use of cyanuric acid; please consult your local authority. NOTE: Cyanuric acid is not needed for indoor pools.

D. pH readings

It is ABSOLUTELY ESSENTIAL that the pH of the pool be maintained in the range of 7.2 – 7.8. Regularly test or ask your pool shop to test the pH level. The effectiveness of chlorine as a sanitizer is significantly reduced as the pH rises. At a pH of 8.0, most of the chlorine being added to the pool is wasted, and it will be almost impossible to maintain a satisfactory free chlorine reading.

E. Super Chlorinate Function

The Super Chlorinate button automatically boosts chlorine levels for a period of 24 hours. During this time it is safe to swim. Use this function only in situations of increased bather load, or if experiencing trouble (see Troubleshooting section). If your chlorine levels are appropriate (0.6 – 3.0 ppm), super chlorinating on a regular basis is not necessary and will raise pH levels and reduce the life of the electrode.

F. Regular maintenance checks

You should always test the chlorine levels of your pool before each use.

DAILY:

- Test the free chlorine.
- Test the total alkalinity. Adjust if necessary.
- Test the pH of the water. Adjust if necessary.

WEEKLY:

- Check the pressure gauge on the pool filter to see if backwashing is necessary.

MONTHLY:

- Test the salt concentration of the pool (see "Salt: When And How To Add It").
- Test the chlorine stabilizer reading. Adjust if necessary.
- Remove any debris that may have passed through the filter and lodged in the electrode. Take care not to scratch or bend the electrode (see "DuoClear Maintenance").

NOTE: Maintaining constantly high levels of salt and chlorine above recommended range can contribute to corrosion of the pool equipment. These levels can be reduced by diluting the pool water with fresh water.

Do not add pool chemicals directly to the skimmer. This may damage the electrode.

G. Spring Start-up

The output of the electrode is determined by water temperature, salt level and mains voltage. In the springtime when the water temperature of the pool is below 18°C (65°F) there may be a reduction in conductivity of the pool water which can cause the Add Salt light to light up and you will not be able to set the output to maximum. There is no need to add salt if the level is already at 4000 ppm. When the water is below 18°C (65°F), there is very little algae growth and it is too cold for swimming so the chlorine does not get used up as much as it would during normal operating conditions. If this is the case, you can leave the DuoClear at a lower output setting until the temperature warms up.

WARNING: Never allow the concentration of free chlorine to go below 0.6 ppm. If this is not possible with the DuoClear system, use a manual application of liquid chlorine (sodium hypochlorite).

H: Backwashing the pool filter

Before backwashing the pool filter, turn off the chlorinator by pushing the On/Off button.

SALT: WHEN AND HOW TO ADD IT

When to add salt

Add salt when indicated on the control panel, except in the case of cold water below 18°C (65°F) or low voltage. See Problem G in the Troubleshooting section. Note that the 'Add Salt' light may switch on at any salt level between 3000 and 4000 ppm, depending upon the water temperature and mains voltage (see note below). This is not a fault but a precaution to ensure that conductivity is never too low. The salt concentration should normally be around 4000 ppm, but should never be allowed to fall below 3000 ppm, as this can reduce the life of the cell electrodes. Salt is not lost through evaporation. Salt is lost only when water is splashed out of the pool or during backwash of the filter. Adding fresh water or rainfall to the pool dilutes the salt concentration. Adding salt may be needed from time to time to maintain an optimum salt level.

NOTE: Even if the salt concentration is around 4000 ppm, the 'Add Salt' light may switch ON if the water temperature drops below 18° C (65° F). In this situation, you may be unable to set the Chlorine Output to maximum. In cold water there is very little chlorine demand and low bather load, therefore the chlorine output can be left at a lower setting, or you may not need to run the DuoClear at all.

How much to add

Use a salt test strip to determine the salt level in pool water prior to adding any salt.

Capture water from elbow depth in a container, then use a test strip in this water sample. If the pool water was previously chlorinated with sodium hypochlorite (liquid chlorine) there will already be residual salt in the pool, therefore it is very important to TEST THE CONCENTRATION OF SALT BEFORE ADDING SALT.

Only 99.5% pure refined, non-iodized salt (sodium chloride) should be used with the DuoClear system. Do not use salt containing yellow prussiate as it may stain the plaster finish of the pool. Add enough salt to obtain a 4000 ppm concentration.

- 1 gram per litre raises the salt level by 1000 ppm.

- In a FRESHLY REFILLED pool (where there is no salt residual) of approximately 80,000 litres, 320 kg of salt are required to reach a 4000 ppm concentration (80,000 x 4)

- Refer to 'Salt Chart' on page 18.

IMPORTANT: To avoid damage to your DuoClear system, never allow salt level to exceed 13,000 ppm.

How to add salt

Evenly disperse the proper amount of salt around the perimeter of the pool. Run the pump and filter for at least 4-6 hours. Allow 24 hours for salt to fully dissolve. If the ADD SALT light is still on after 24 hours, test the salt level and add the necessary salt to obtain a 4000 ppm concentration. Note: Do not add salt to the skimmer box.

SALT CHART

The following is a chart to determine the amount of salt required to raise a pool to 4000 parts per million

	Current Salt Level in Parts Per Million (ppm)								
	0	500	1000	1500	2000	2500	3000	3500	
10 000	40 kg	35 kg	30 kg	25 kg	20 kg	15 kg	10 kg	5 kg	
20 000	80 kg	70 kg	60 kg	50 kg	40 kg	30 kg	20 kg	10 kg	
30 000	120 kg	105 kg	90 kg	75 kg	60 kg	45 kg	30 kg	15 kg	
40 000	160 kg	140 kg	120 kg	100 kg	80 kg	60 kg	40 kg	20 kg	
50 000	200 kg	175 kg	150 kg	125 kg	100 kg	75 kg	50 kg	25 kg	
60 000	240 kg	210 kg	180 kg	150 kg	120 kg	90 kg	60 kg	30 kg	
70 000	280 kg	245 kg	210 kg	175 kg	140 kg	105 kg	70 kg	35 kg	
80 000	320 kg	280 kg	240 kg	200 kg	160 kg	120 kg	80 kg	40 kg	
90 000	360 kg	315 kg	270 kg	225 kg	180 kg	135 kg	90 kg	45 kg	
100 000	400 kg	350 kg	300 kg	250 kg	200 kg	150 kg	100 kg	50 kg	
110 000	440 kg	385 kg	330 kg	275 kg	220 kg	165 kg	110 kg	55 kg	
120 000	480 kg	420 kg	360 kg	300 kg	240 kg	180 kg	120 kg	60 kg	
130 000	520 kg	455 kg	390 kg	325 kg	260 kg	195 kg	130 kg	65 kg	

Note: There may already be some salt present in the water. Be sure to test the salt level prior to adding any. Do not operate the Clearwater until the salt has dissolved as this will cause damage to the unit. Be conservative when adding salt as it is easier to add more if needed than it is to dilute if there is too much salt.

For more information please contact Zodiac Pool Systems Canada Inc. at 1-888-647-4004

STABILIZER (CYANURIC ACID) CHART

The following is a chart to determine the amount of stabilizer (cyanuric acid) in kg required to raise a pool to 60 parts per million

	Current Stabilizer Level in Parts Per Million (ppm)						
	0	10	20	30	40	50	
10 000	0.6 kg	0.5 kg	0.4 kg	0.3 kg	0.2 kg	0.1 kg	
20 000	1.2 kg	1.0 kg	0.8 kg	0.6 kg	0.4 kg	0.2 kg	
30 000	1.8 kg	1.5 kg	1.2 kg	0.9 kg	0.6 kg	0.3 kg	
40 000	2.4 kg	2.0 kg	1.6 kg	1.2 kg	0.8 kg	0.4 kg	
50 000	3.0 kg	2.5 kg	2.0 kg	1.5 kg	1.0 kg	0.5 kg	
60 000	3.6 kg	3.0 kg	2.4 kg	1.8 kg	1.2 kg	0.6 kg	
70 000	4.2 kg	3.5 kg	2.8 kg	2.1 kg	1.4 kg	0.7 kg	
80 000	4.8 kg	4.0 kg	3.2 kg	2.4 kg	1.6 kg	0.8 kg	
90 000	5.4 kg	4.5 kg	3.6 kg	2.7 kg	1.8 kg	0.9 kg	
100 000	6.0 kg	5.0 kg	4.0 kg	3.0 kg	2.0 kg	1.0 kg	
110 000	6.6 kg	5.5 kg	4.4 kg	3.3 kg	2.2 kg	1.1 kg	
120 000	7.2 kg	6.0 kg	4.8 kg	3.6 kg	2.4 kg	1.2 kg	
130 000	7.8 kg	6.5 kg	5.2 kg	3.9 kg	2.6 kg	1.3 kg	

For more information please contact Zodiac Pool Systems Canada Inc. at 1-888-647-4004

The above chart is for general reference only. The recommended stabilizer reading is between 30-100 ppm and will vary dependent on geographic climate. Warm, sunny climates will require a stabilizer reading at the higher end of the given range. Consult your local pool professional for your optimum level. Always add stabilizer according to the manufacturer's instructions.

SOME TIPS ON WATER CHEMISTRY

How to adjust pH

A pH range of 7.2 – 7.8 is ideal for maximum comfort and chlorine efficacy. **Always adjust total alkalinity before adjusting pH.**

Low pH (acidic water) leads to stinging eyes and corrosion of open metal fittings. Raise the pH by adding sodium bicarbonate or soda ash. Consult your pool professional regarding which chemical is best for your situation and the proper amount to use. Check the pH after 4 hours of circulation, adjusting as necessary to achieve the proper range.

High pH (alkaline water) leads to clouding of the water and reduces the amount of active chlorine. This means algae and bacteria can grow. Lower the pH by adding muriatic acid to the pool water. The acid demand indicated by your 4-in-1 test kit will show the amount of acid to use. **WARNING: ALWAYS ADD ACID TO WATER, NEVER WATER TO ACID.**

If your pH remains inconsistent, check your total alkalinity.

Total alkalinity affects pH

Total alkalinity is a measure of the alkaline chemicals in your pool water (e.g. bicarbonates, carbonates, and hydroxides). It can be thought of as the buffering system necessary to control pH. Low alkalinity can allow pH to fluctuate or drift rapidly in one direction. The pH will be difficult to maintain and staining of pool surfaces may occur when total alkalinity is too low.

Total alkalinity should be in the range of 100 – 120 ppm. Total alkalinity is often confused with pH. They are related, however distinct. To raise total alkalinity, add pH buffer (sodium bicarbonate) at the rate shown in the manufacturer's instructions to achieve a reading in the 100 – 120 ppm range. 180 g of sodium bicarbonate raises 10,000 litres of pool water by 10 ppm.

To lower the total alkalinity, use muriatic acid. The acid demand chart in your 4-in-1 test kit will indicate the necessary amount to add. Adjust as needed until the reading (taken at least 24 hours later) is in the 100 – 120 ppm range. When total alkalinity is correct, you may need to adjust pH. **WARNING: ALWAYS ADD ACID TO WATER, NEVER WATER TO ACID.**

Use of algaecides and phosphate removers

Algaecides may be used in conjunction with a DuoClear system but are usually not necessary. Only use ammonia based poly-quat algaecides. Do not use copper based algaecides. Phosphate removers may also be used in conjunction with a DuoClear system and may be helpful in high phosphate regions where algae growth can be a problem. Phosphates enter the water from a variety of sources such as fertilizer, soaps and run off. High phosphate levels will cause chlorine destruction. Contact your local pool professional for phosphate testing and information regarding the presence of phosphates in your local area. Always follow manufacturer's instructions for treatment.

The chlorine and copper from the DuoClear system is the best defence against algae and is usually all that is necessary. If algae is observed however, brush spot thoroughly, adjust pH, super-chlorinate with your DuoClear system or manually shock pool water with either liquid or granular chlorine. A chlorine residual should be measurable within 24 hours. If not, repeat shock treatment (see page 21). After

shocking, check to ensure that the DuoClear system is maintaining a residual chlorine level to prevent future algae growth. With extreme algae conditions, manually shocking the pool is the best option. Note: Overuse of algaecides can lead to a reduction in chlorine residual because algaecides can negatively react with the chlorine produced by the DuoClear system. When using algaecides, always follow manufacturer's instructions and adjust the output of the DuoClear system to maintain a residual chlorine level.

The addition of certain chemicals can reduce the effectiveness of chlorine. Always make sure that proper residual chlorine levels are maintained to avoid illness.

Use of sequestering agents

In some areas the total hardness of your source water may be unusually high. High total hardness can contribute to scale formation in the pool. Sequestering agents will help keep minerals in solution and under some conditions can prevent this from happening. Consult your pool professional about the use of a sequestering agent.

Use of chlorine stabilizer (cyanuric acid) to protect chlorine residual.

This chemical acts as a sun-screen for chlorine and prevents chlorine from being too quickly destroyed by the sun. Chlorine stabilizer is essential to prolong the life of chlorine in the pool water. It should be added following the manufacturer's instructions to achieve a level of 30 – 100 ppm depending on geographical climate. Refer to stabilizer chart on page 18.

WINTERIZING YOUR POOL

Use these steps as a guide. Consult your dealer for specific information in your area.

Warm Climate

1. Reduce the number of hours the pump runs since the cooler weather decreases the spread of algae and other pollutants.
2. There is no need to shock the pool during cool weather unless the water becomes cloudy (as may occur after a winter storm).

Cold Climate

1. Check total alkalinity and pH of pool to make sure that they are in proper balance.
2. Vacuum the pool bottom to remove any debris or other potential contaminants.
3. Shock the pool with chlorine according to manufacturer's instructions to clear the water.
4. Add a winter algaecide following manufacturer's instructions.
Important: Do *not* use a winter algaecide with copper in it. This will void the DuoClear no-stain warranty.
5. Backwash the filter.
6. Drain part of the pool water. The amount to drain varies from one part of the country to another. Consult your dealer for advice.
7. Leave the cartridge and electrode inside the vessel for the winter. Remember to change the cartridge upon opening the pool next spring.
8. Winterize the pipes with pool antifreeze following manufacturer's instructions.
9. Drain the water out of all equipment (pump, filter, etc.).
10. Store all baskets, hoses and cleaning equipment, indoors if possible.
11. Cover the pool with a winter cover.

TROUBLESHOOTING

Problem A – Water looks clean but no chlorine residual reading

To test for chlorine residual, switch on the filtration system and adjust the DuoClear system to maximum output. After a few hours take a water sample from the pool. Test this water with your test kit. Chlorine residual should measure between 0.6 and 3.0 ppm.

REMEDY:

- Adjust total alkalinity to 100 – 120 ppm.
- Adjust the pH within the range 7.2 – 7.8.
- Make sure your electrode is clean.
- Check cyanuric acid (stabilizer) level. Chlorine stabilizer is needed to protect chlorine residual.
- Increase the setting of the output control.
- Increase the running time of the filter and chlorinator. Make sure that the filter is clean and functioning properly.
- Add salt if indicated by the 'Add Salt' light.
- Manually shock the pool.

Problem B – Pool is green and there is no chlorine reading

Chlorine is still considered the most effective way of destroying algae and bacteria in your pool water. A chlorine residual of 0.6 to 3.0 ppm is appropriate with the DuoClear system. Higher chlorine levels are required to destroy an algae build-up.

REMEDY:

Use the DuoClear 'Super Chlorinate' feature or manually shock the pool with sodium hypochlorite. This will raise the chlorine residual to a very high level for a short period of time, and reduce chlorine demand.

Super Chlorinate with DuoClear:

- I. Backwash the filter
- II. Adjust the pH to within the range 7.2 – 7.8. See 'Some Tips on Water Chemistry'
- III. Press the button marked 'Super Chlorinate'. The DuoClear automatically increases its output and runs for approx. 24 hours of pool pump time.
- IV. After 24 hours, backwash the filter.
- V. Re-adjust the pH 7.2 – 7.8.
- VI. Check the chlorine reading
- VII. If there is still no chlorine residual, apply a manual shock as described below. If the chlorine reading improved but is still too low, repeat steps (III) to (VI) of this section until the chlorine reading is satisfactory.

Manually shock with chlorine or oxidizing agents:

- I. Backwash the filter.
- II. Adjust the pH to within the range 7.2 – 7.8 (See "Some Tips on Water Chemistry" on pages 19 – 20).
- III. Follow the manufacturer's instructions of the shock product being used.
- IV. After shock dosing, re-adjust the pH to within the range of 7.2 – 7.8 and check the chlorine level. Allow the chlorine residual to drop back down to 0.6 – 3.0 ppm before using the pool.

Problem C – Chlorine odour

CAUSE: Presence of excess chloramines (combined chlorine).

Surprisingly, the problem here is not too much chlorine as many imagine. Chloramines form by the bonding of chlorine with amines from sweat and other sources. These chloramines can create a chlorine odour and can also cause eye and skin irritation. Free chlorine does not smell (up to 10 ppm concentration).

REMEDY:

Manually shock the pool following the directions in Problem B.

Problem D – Slimy walls of pool

CAUSE: Combined algae and bacteria growth.

REMEDY:

Brush down the affected walls and follow shock treatment directions in Problem B.

Problem E – Eye and/or skin irritation

CAUSE: Improper water balance.

REMEDY:

Balance the water (See 'Tips on Water Chemistry').

Problem F – Scale formation on pool equipment

To clean the deposit (scale) from the electrode plates, see DuoClear Maintenance section.

CAUSE 1: Incorrect pH causing metals to come out of solution

REMEDY:

Adjust total alkalinity to 100 – 120 ppm. Then adjust the pH to within the range 7.2 – 7.8 (See 'Some Tips on Water Chemistry').

CAUSE 2: High total hardness

REMEDY:

Dilute pool with fresh water. Consult your pool professional regarding use of a sequestering agent.

Problem G – Chlorine Output will not reach maximum - Add Salt light may also be on

CAUSE 1: Low incoming voltage.

REMEDY:

Confirm DuoClear system is wired to a 220 – 240 VAC source. If incoming voltage is less than 220 VAC due to location (rural areas for example), raising the salt level will compensate.

CAUSE 2: Salt level below 4000 ppm

REMEDY:

Add salt. (See "Salt: When and How to Add")

CAUSE 3: Water temperature is below 18°C (65° F).

The output of the electrode is determined by water temperature, salt level and mains voltage. In the springtime when the water temperature of the pool is below 18°C (65°F) there may be a reduction in conductivity of the pool water which can cause the Add Salt light to light up and you will not be able to set the output to maximum. There is no need to add salt if the level is already at 4000 ppm. When the water is below 18°C (65°F), there is very little algae growth and it is too cold for swimming so the chlorine does not get used up as much as it would during normal operating conditions.

REMEDY:

You can leave the DuoClear at a lower output setting until the temperature warms up.

WARNING: Never allow the concentration of free chlorine to go below 0.6 ppm. If this is not possible with the DuoClear system, use a manual application of liquid chlorine (sodium hypochlorite).

CAUSE 4: Electrode is reversing polarity (self clean).

REMEDY:

If the cell is reversing polarity, the yellow light on the Chlorine Output indicator will flash. Wait approximately three minutes and the output should return to normal.

CAUSE 5: Electrode is nearing the end of its life.

REMEDY:

Replace electrode. Use only replacement electrodes having a label that clearly states that it is a replacement cell for the DuoClear system of the appropriate model.

CAUSE 6: Electronics malfunctioning.

REMEDY:

Call Zodiac Pool Systems Canada Inc. at 1-888-647-4004 for further instructions.

Problem H – ‘No Flow’ light on

CAUSE 1: Insufficient water flow through the cell.

REMEDY:

Ensure sufficient water flow through chlorinator cell. Verify that the filter pump is on. Flow may be restricted if the filter needs backwashing.

WARNING: Operating the DuoClear system without water flow through the cell can cause a build up of flammable gases which can result in FIRE OR EXPLOSION.

CAUSE 2: Electrode plug is disconnected or loose.

REMEDY:

Ensure that the electrode plug is tightly connected.

Problem I – Chlorinator stops working, all lights OFF

CAUSE 1: Unit turned off.

REMEDY:

Push ON/OFF button. A yellow light in the Chlorine Output indicator window is present when the unit is “ON”.

CAUSE 2: Mains power removed or blown fuse.

REMEDY:

Your DuoClear system must be connected and properly grounded to the electrical power source. Check mains power source and fuse on underside of power pack. To reset the fuse, turn off all power to the DuoClear power pack. The fuse is located beside the power cord on the underside of the DuoClear power pack unit. If the fuse is blown (popped with white area exposed), push to reset. Restore power to unit. If fuse continues to trip contact Zodiac Pool Systems Canada Inc. at 1-888-647-4004.

CAUSE 3: Component failure within power pack.

REMEDY:

Call Zodiac Pool Systems Canada Inc. at 1-888-647-4004.

Problem J – Chlorine level is too high

CAUSE 1: Chlorinator is manufacturing too much chlorine.

REMEDY 1:

Use the output button to reduce setting. Retest chlorine daily until proper level is attained.

REMEDY 2:

Manually turn chlorinator off. The DuoClear uses a smart switch that turns the chlorinator on automatically with each pump cycle.

REMEDY 3:

If chlorine output at the lowest setting consistently provides for excessive chlorine levels, decrease daily pump operation time as much as necessary. If chlorine output at lowest setting is still excessive the DuoClear is oversized for the pool.

Any type of electrical troubleshooting should be handled by a qualified pool professional or certified electrician.

WARRANTY INFORMATION

The limited warranties contained within this document are the only warranties given with your DuoClear system and supersede any prior warranties. All other warranties, expressed or implied, including the implied warranty of merchantability or the implied warranty of fitness for a particular purpose are hereby disclaimed. Our sole obligation under this warranty, and the purchaser's sole remedy, is limited to the repair or replacement of the DuoClear, or one of its parts. This DuoClear Warranty applies to the original owner only.

POWER PACK, VESSEL AND ELECTRODE WARRANTY

The manufacturer warrants this DuoClear system to be free of defects in materials and workmanship for a period of three (3) years from the date of purchase. If no proof of purchase date is supplied, the warranty period begins on the date of manufacture as encoded on the product. The cost of field service calls and/or freight cost to return goods for repair are not covered by this warranty.

NATURE2 CARTRIDGE WARRANTY

The Nature2 Purifier cartridge is warranted to be free of defects in materials and workmanship for a period of six months from the date of purchase.

EXCLUSIONS FROM WARRANTY

The DuoClear system is designed for residential use only and any commercial application voids all warranty. If the unit is used in any application other than as an inground swimming pool sanitizing system, the purchaser and/or end-user releases the manufacturer from any and all claims related to the use of the DuoClear system.

This warranty does not cover problems arising from whole or in part from purchaser's or user's negligence, misuse or abuse, improper maintenance or installation, accident, improper application, failure to follow all safety instructions or precautions, Acts of God, abnormal weather conditions, damage from plants or animals, and improper use of chemicals.

This warranty specifically excludes all incidental or consequential damages, except where state law requires them to be paid. This warranty gives you specific rights. You may have other rights that vary from province to province.

TO SUBMIT A CLAIM

Report claims to Zodiac Pool Systems Canada Inc. by calling 1-888-647-4004. Only the original purchaser may submit a claim under this limited warranty. Proof of purchase is required to make any claims on the above warranties, so please keep your dated receipt.

For more information consult your pool care professional or call 1-888-647-4004.

Due to constant developments and improvements, specifications may change without notice.

This label transcript service is offered by the Pest Management Regulatory Agency to provide efficient searching for label information. This service and this information do not replace the official hard-copy label. The PMRA does not provide any guarantee or assurance that the information obtained through this service is accurate, current or correct, and is therefore not liable for any loss resulting, directly or indirectly, from reliance upon this service.