

2021-3369
2022-07-12

FRONT OF THE BOX

CLEANSLATE UV SANITIZER
Ultraviolet Radiation Emitting Device

COMMERCIAL
REGISTRATION NO. 34495 *PEST CONTROL PRODUCTS ACT*

KEEP OUT OF REACH OF CHILDREN
READ LABEL AND OPERATOR'S MANUAL BEFORE USING.

When used as a supplement to regular cleaning practices, the CleanSlate UV sanitizer kills 99.99% of bacteria and 99.9% of viruses on hard, non-porous surfaces, after one 20-second cycle.

WARNING – Risk of electric shock. Disconnect power before servicing.

[certification logo]
Model: CSUV-UG6CX

CleanSlate UV
123 Edward St, Suite 209
Toronto ON, M5G 1E2
Canada

+1-877-553-6778
www.cleanslateuv.com

BACK OF THE BOX

PRECAUTIONS

- WARNING – UV radiation emitted from this device.
- Unintended use of the device, or damage to the housing, may result in exposure to ultraviolet radiation.
- Ultraviolet radiation may cause eye and skin irritation.
- Avoid exposing eyes and skin to ultraviolet radiation.

DIRECTIONS FOR USE

Please refer to the Operator's Manual.

NOTICE TO USER: This pest control product is to be used only in accordance with the directions on the label. It is a violation under the *Pest Control Products Act* to use this product in a manner that is inconsistent with the directions on the label.

SIDE OF THE BOX

The use of this device is a supplement to, and not a substitute for, standard infection control practices; users must continue to follow all current infection control practices, including those practices related to cleaning and disinfection of environmental surfaces.

When used as a supplement to regular cleaning practices, the CleanSlate UV Sanitizer Kills 99.99% of bacteria including methicillin-resistant *Staphylococcus aureus* (MRSA)(ATCC 33591 and ATCC 33592), and 99.9% of viruses including SARS-CoV-2, the virus that causes COVID-19, on hard non-porous surfaces after one 20 second sanitization cycle.

In the event that replacement of the lamps is necessary, follow the instructions in the operating manual for the device. For disposal of lamps, dispose or recycle according to local applicable laws.

Items suitable for sanitization with this device includes but is not limited to, cell phones, tablets, watches, radios, ID badges, and other mobile communication devices/tools.

To sanitize an object:

Pre-clean the object before placing it in the device.

- Pre-clean the object before placing it in the device
- Gently place items in the front tray
- Note: If placing multiple items, ensure they are placed within blue lines and are at least 2.5 cm (1 inch) apart.
- Close the front lid. The sanitization cycle will start automatically
- When the cycle is complete the lid will automatically open
- Retrieve items

Refer to the Operator's Manual for full instructions on the use and operation of this device.

Primary Display Panel on the device

CLEANSLATE UV SANITIZER

COMMERCIAL

REGISTRATION NO. 34495 *PEST CONTROL PRODUCTS ACT*

READ THE LABEL AND OPERATOR'S MANUAL BEFORE USING

KEEP OUT OF REACH OF CHILDREN

WARNING

Risk of electric shock. Disconnect power before servicing.

Secondary Display Panel on the device

PRECAUTIONS:

- WARNING - UV radiation emitted from this device.
- Unintended use of the device, or damage to the housing, may result in exposure to ultraviolet radiation.
- Ultraviolet radiation may cause eye and skin irritation.
- Avoid exposing eyes and skin to ultraviolet radiation.

DIRECTIONS FOR USE:

The use of this device is a supplement to, and not a substitute for, standard infection control practices; users must continue to follow all current infection control practices, including those practices related to cleaning and disinfection of environmental surfaces.

To sanitize an object:

Pre-clean the object before placing it in the device.

- Pre-clean the object before placing it in the device
- Gently place items in the front tray
- Note: If placing multiple items, ensure they are placed within blue lines and are at least 2.5 cm (1 inch) apart.
- Close the front lid. The sanitization cycle will start automatically
- When the cycle is complete the lid will automatically open
- Retrieve items

In the event that replacement of the lamps is necessary, follow the instructions in the operating manual for the device. For disposal of lamps, dispose or recycle according to local applicable laws.

For additional information, please refer to the Operator's Manual.

cleanslate UV

Operator's Manual

CLEANSLATE UV SANITIZER
Ultraviolet Radiation Emitting Device

COMMERCIAL
REGISTRATION NO. 34495
PEST CONTROL PRODUCTS ACT

KEEP OUT OF REACH OF CHILDREN
READ THE LABEL AND OPERATOR'S MANUAL BEFORE USING

When used as a supplement to regular cleaning practices, the CleanSlate UV sanitizer kills 99.99% of bacteria and 99.9% of viruses on hard, non-porous surfaces, after one 20-second cycle.

WARNING - Risk of electric shock. Disconnect power before servicing.

Model: CSUV-UG6CX

CleanSlate UV
123 Edward St, Suite 209
Toronto ON, M5G 1E2
Canada

+1-877-553-6778
www.cleanslateuv.com

Patent

Application number 15/568,927. Additional U.S. and foreign patents pending.

FCC Compliance Statement

This device complies with Part 15 of the FCC Rules. Operation is subject to the following two conditions: (1) this device does not cause harmful interference, and (2) this device must accept any interference received, including interference that may cause undesired operation. Any changes/modifications to this equipment not approved by USR IOT Technology could void the user's authority to operate the equipment.

FCC ID: 2AC7Z-ESP32WROOM32U

Industry Canada: 21098-ESPWROOM32U

Certification License Holder

Limestone Labs Limited

123 Edward St, Suite 209

Toronto, ON M5G 1E2, Canada

















+1 (877) 553-6778

Table of Contents













A. INTRODUCTION AND SAFETY	5
A.1 Symbols and Descriptions	5
A.2 Safety and Warnings	6
A.3 Message from CleanSlate	8
A.4 Solution Overview	9
A.5 Cleaning Before Sanitization	9
A.6 Recommended Devices	9
B. DEVICE OVERVIEW, SET-UP AND USE	10
B.1 Parts and Features	10
B.2 What's In The Box	11
B.3 Initial Setup	11
B.4 Directions For Use	15
B.5 CleanSlate UV Sanitizer Placement	16
B.6 Lifting the CleanSlate UV Sanitizer	16
C. TROUBLESHOOTING	17
C.1 Regular Stop	17
C.2 Device Restart	17
C.3 Device Retrieval in Case of Power Failure	17
C.4 Error Diagnosis	18
D. MAINTENANCE	19
D.1 Bulb Replacement	19
D.2 Language Selection	20
D.3 Communication Protocol	20
D.4 Disposal of UVC Bulbs	20
D.5 Recycling Resources	20
D.6 Broken Bulb Procedure	20
D.7 Quartz Glass	21
E. CLEANING.....	22
E.1 Internal	22
E.2 External	22
F. SPECIFICATIONS AND ACCESSORIES.....	23
F.1 Performance and Technical Specifications	23
F.2 Replacement Parts and Accessories	24
G. CUSTOMER SUPPORT AND WARRANTY	25
G.1 Contact Info	25
G.2 Limited Warranty	25
H. FREQUENTLY ASKED QUESTIONS	27

A. Introduction and Safety

A.1 Symbols and Descriptions

	This is the safety alert symbol. It is used to alert you to potential personal injury hazards. Obey all safety messages that follow this symbol to avoid possible injury or death.
	This symbol is used to identify an ELECTRICAL SHOCK or ELECTROCUTION hazard.
	This symbol is used to identify an ULTRAVIOLET LIGHT hazard.
	The symbol is used to identify the need to wear approved ultraviolet resistant eyewear.
	This symbol is used to identify the need to wear protective gloves.
	This symbol is used in support of the WEEE Directive, specifically indicating there are products containing mercury (Hg) that should not be disposed of with general household waste. Please visit www.lamprecycle.org or call 1-800-555-0050 for information in your jurisdiction.
	This symbol indicates to consult the instructions or user's manual for more information.
	This symbol indicates to refer to the user's manual for information when servicing the device.
	This symbol indicates fuse information.
	This symbol is used to indicate the product model number.
	This symbol is used to identify the product's unique serial number.
	This symbol is used to indicate the year the product was manufactured.
	This symbol is used to indicate the Restriction of Hazardous Substances (RoHS) Directive compliance.
	This symbol is used to indicate product conformity with the essential safety requirements set out in European Directives.
	This symbol is used to indicate product conformity with the essential safety requirements set out in Australia and New Zealand.
	This symbol is used to indicate that the product is safe and emissions tested by certification body TÜV SÜD for both Canada and the United States.

A.2 Safety and Warnings

	<p>PRECAUTIONS</p> <ul style="list-style-type: none"> • WARNING: UV radiation emitted from this device. • WARNING: Risk of electric shock. Disconnect power before servicing. • Unintended use of the device, or damage to the housing, may result in exposure to ultraviolet radiation. • Ultraviolet radiation may cause eye and skin irritation. • Avoid exposing eyes and skin to ultraviolet radiation. Avoid looking directly at the light. • If you can directly see the UV light during operation, immediately turn off and call customer support
	<p>DANGER: Electrical shock hazard. To prevent electrical shock, disconnect the power source before servicing.</p>
	<p>WARNING: UVC light is harmful to living organisms. Never put any pets into the CleanSlate UV Sanitizer.</p>
	<p>WARNING: Do not attempt to move the CleanSlate UV Sanitizer tray before turning off the power.</p>
	<p>WARNING: The CleanSlate UV Sanitizer device is not a sterilizer. Never use it in place of a sterilizer, and never utilize it to clean any items that will come in contact with mucous membranes or non-intact skin.</p>
	<p>WARNING: No one under the age of 14 should operate the CleanSlate UV Sanitizer.</p>
	<p>WARNING: Do not remove any instruction, warning or caution labels from the CleanSlate UV Sanitizer.</p>
	<p>WARNING: The CleanSlate UV Sanitizer must always be connected to a grounded three-prong electrical outlet.</p>
	<p>WARNING: The ultra-violet lamps contain mercury. All replacement lamps must be discarded following the manufacturer's recommendations.</p>
	<p>WARNING: Mercury Hazard. Be careful not to break the bulb during replacement. UVC bulbs contain a small amount of mercury, which can cause injury if inhaled or ingested. For more information on clean up and disposal, see www.lamprecycle.org</p>
	<p>WARNING: If the CleanSlate UV Sanitizer is used in a manner not specified in this manual, the protection provided by the equipment may be impaired.</p>
	<p>CAUTION: UVC light may discolour plastic and rubber over time.</p>



Do not use any other power cord other than the one supplied with the unit.

A.3 Message from CleanSlate

Dear Customer -

Thank you for purchasing a CleanSlate UV Sanitizer, and congratulations on taking the next step towards a cleaner facility.

You have received a 3rd Generation CleanSlate UV sanitization system - the product of significant innovation, testing, and a high-quality manufacturing and design process. This product is backed by a 1-year warranty and an industry-leading support team.

As a CleanSlate UV customer, your satisfaction is our **number one priority**. In this booklet, you will find instructions for the set-up maintenance and safe use of your CleanSlate UV Sanitizer unit. In the event something should go wrong, this will also give information on basic troubleshooting as well as technical support.

Should you ever have a question, need support, or want to order new parts, please visit www.cleanslateuv.com or email us at info@cleanslateuv.com or call us toll-free at +1 (877) 553-6778.

Have a great day.

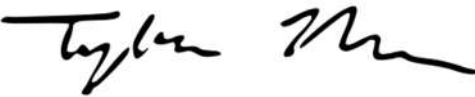

Taylor Mann, CEO

A.4 Solution Overview

CleanSlate UV Sanitizer is a solution for sanitizing smartphones, tablets and other non-critical devices in facilities where bacterial reduction is a priority. When used as a supplement to regular cleaning practices, the CleanSlate UV Sanitizer kills 99.99% of bacteria and 99.9% of viruses on hard, non-porous surfaces, after one 20-second sanitization cycle.

The CleanSlate UV Sanitizer is designed to integrate into numerous workflow layouts easily. It can be placed on a table, desk or custom-stand, and is most effective in higher traffic areas. Moreover, the intuitive design allows it to be used by staff and visitors alike, requiring no training. This means it can be placed at a nursing station, a unit entrance, in a waiting room, or anything in-between.

The CleanSlate UV Sanitizer's purpose is to ensure that the devices we carry around and continuously touch are effectively, reliably and quickly sanitized throughout a workday or during a visit.

A.5 Cleaning Before Sanitization

CleanSlate UV Sanitizer is only a surface sanitization device, and the germicidal light will not penetrate thick biofilm or physical residue. We recommend that devices with visible or heavy soiling be wiped off with a damp microfiber cloth before being placed inside CleanSlate UV Sanitizer. Cleaning is not sanitization, and sanitization is not cleaning.

A.6 Recommended Devices

The CleanSlate UV Sanitizer should only be used to sanitize **non-critical** devices, equipment and personal devices.



CAUTION: UVC light may discolour plastic and rubber over time.

B. Device Overview, Set-up and Use

B.1 Parts and Features

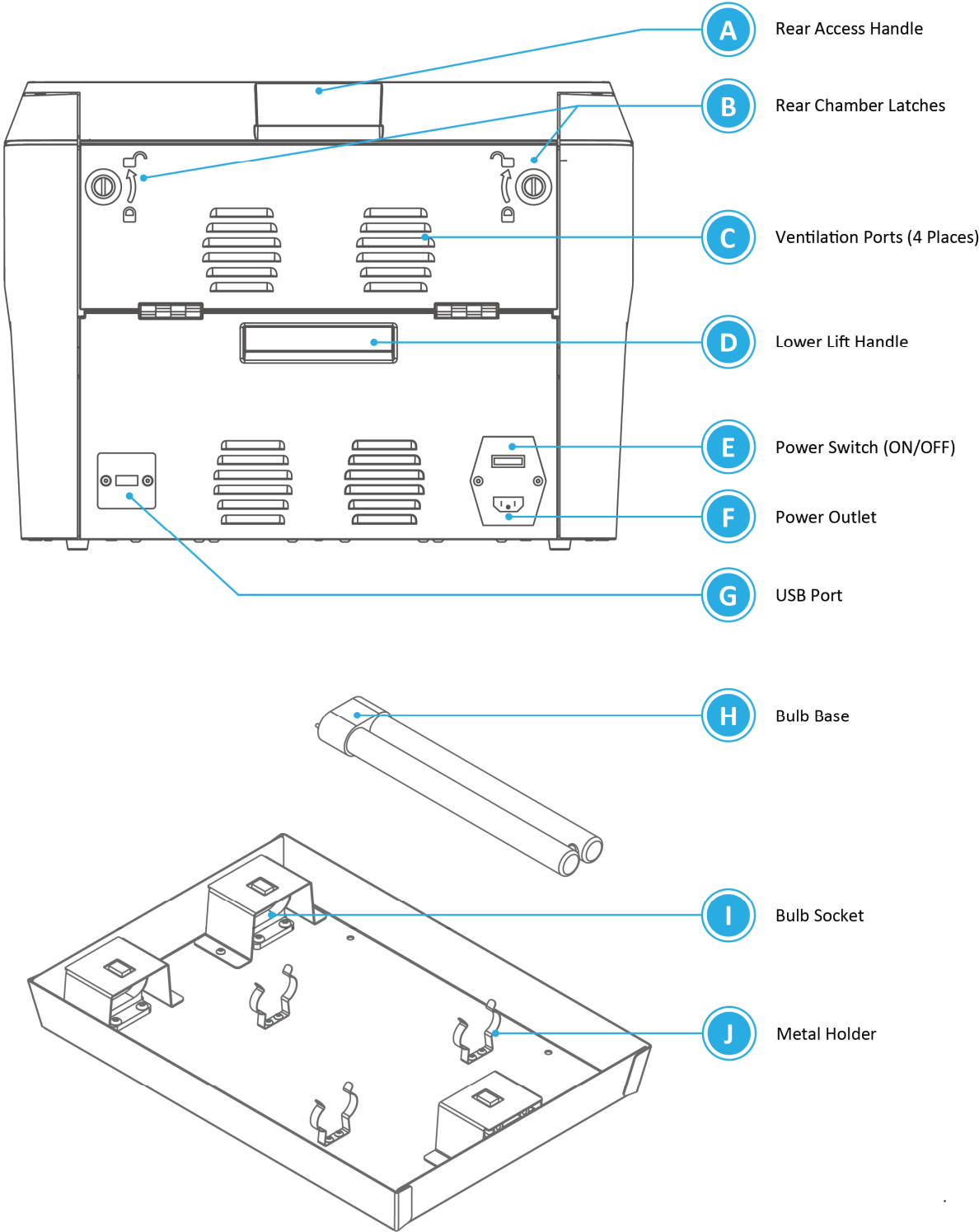

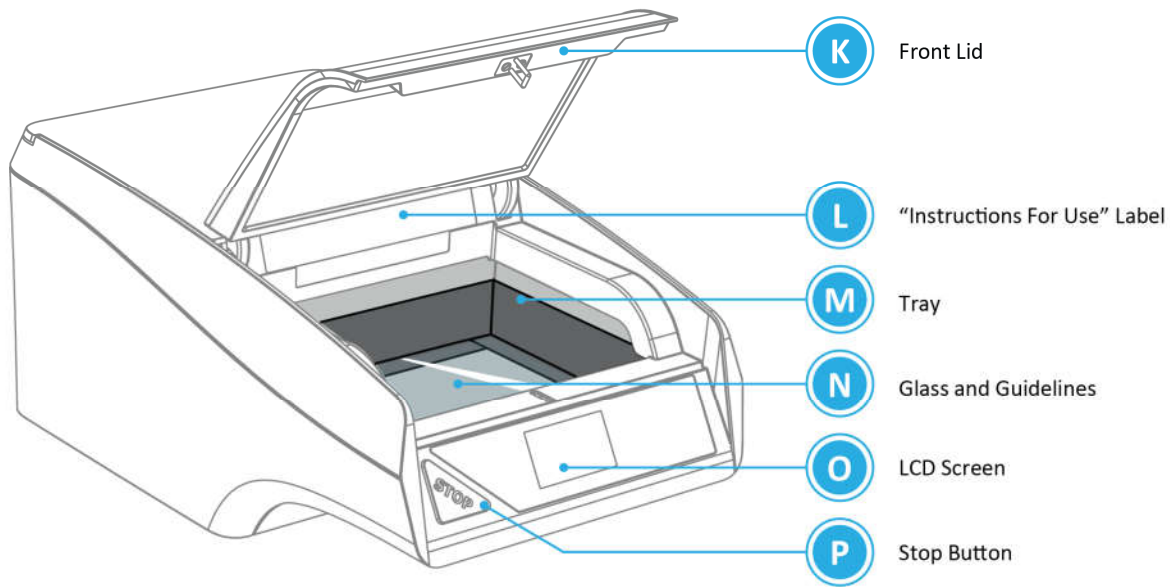

B.2 What's In The Box

- CleanSlate UV Sanitizer unit
- One (1) box containing six (6) germicidal bulbs
This is located in the rear chamber of the unit
- One (1) unboxing guide
- One (1) user manual
- A box containing one (1) piece of quartz glass
- A foam wedge containing:
 - One (1) three-pronged power cord
 - One (1) small flathead screwdriver
- One (1) pair of nitrile gloves

B.3 Initial Setup

1. Remove the foam wedge from the box. This includes the power cord and a flathead screwdriver.
2. Remove the CleanSlate UV Sanitizer unit from the packaging and place it on a table. The CleanSlate UV Sanitizer should have at least 40 cms (~16 inches) of clearance behind the unit.
3. Using the flathead screwdriver provided, rotate the rear latches to unlock the rear access panel. *Arrows beside each latch indicate which direction locks and unlocks the rear chamber latches.*

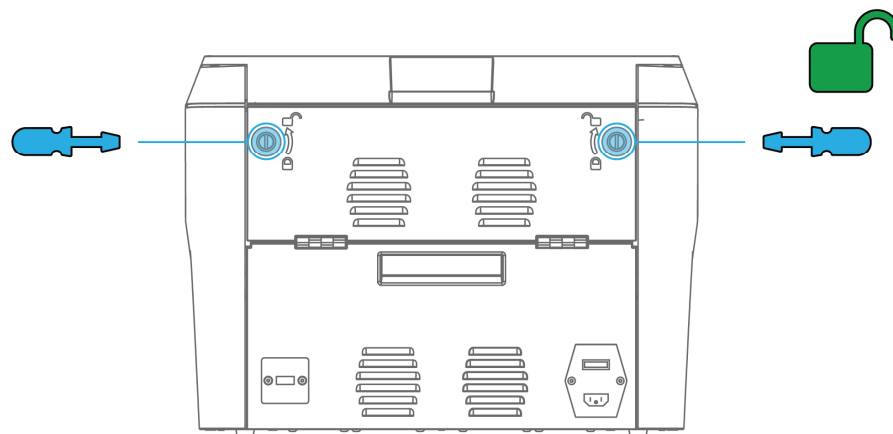

4. To access the rear chamber, gently pull the handle located at the top of the rear chamber away from the unit.

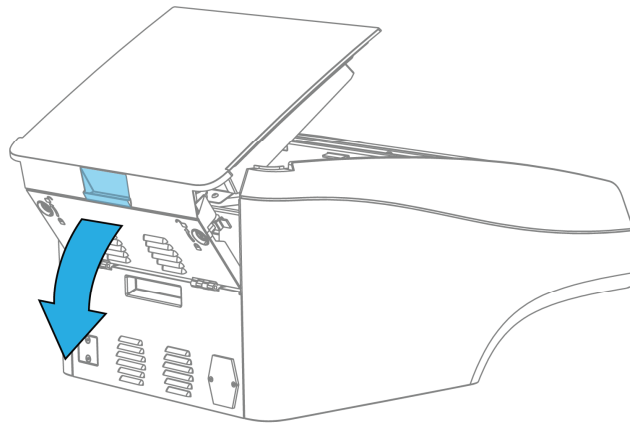

5. Once you have opened the rear chamber, remove the box with the foam rings and place it aside. This box contains the six (6) germicidal bulbs which will need to be installed in the CleanSlate UV Sanitizer before use.

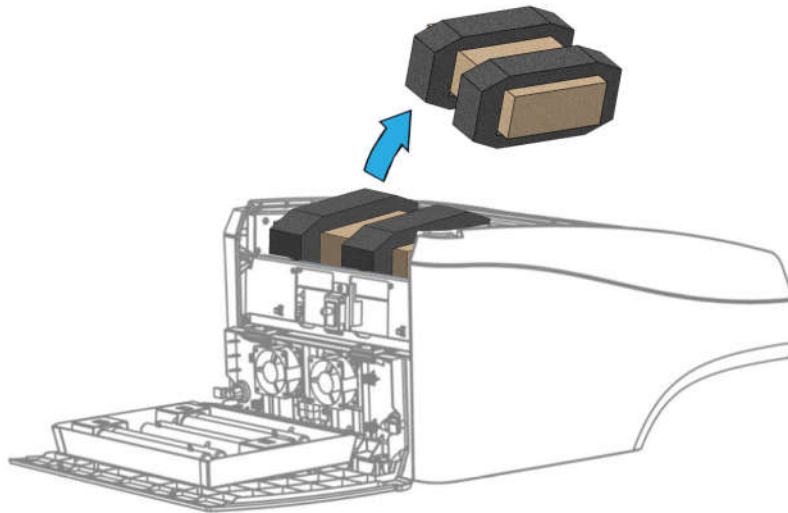

Before proceeding, please put on the gloves provided. You will require the gloves from steps 6 through 24.

6. Remove the foam rings and open the cardboard box to reveal the germicidal bulbs.
7. To install the germicidal bulbs into the CleanSlate UV Sanitizer unit:
 - 7.1 Carefully remove one bulb from the box and place the bulb base halfway into the bulb socket.
 - 7.2 Apply gentle pressure to flex the metal holder outwards and push the bulb down until the holder snaps over-top of the bulb.
 - 7.3 While grabbing the white base of the bulb, push it firmly into the bulb socket. You should hear a “click” indicating that the bulbs have snapped in place.
Note: it is normal for this to take several tries.
 - 7.4 Repeat steps 7.1 thru 7.3 to install the remaining five (5) germicidal bulbs into the CleanSlate UV Sanitizer.

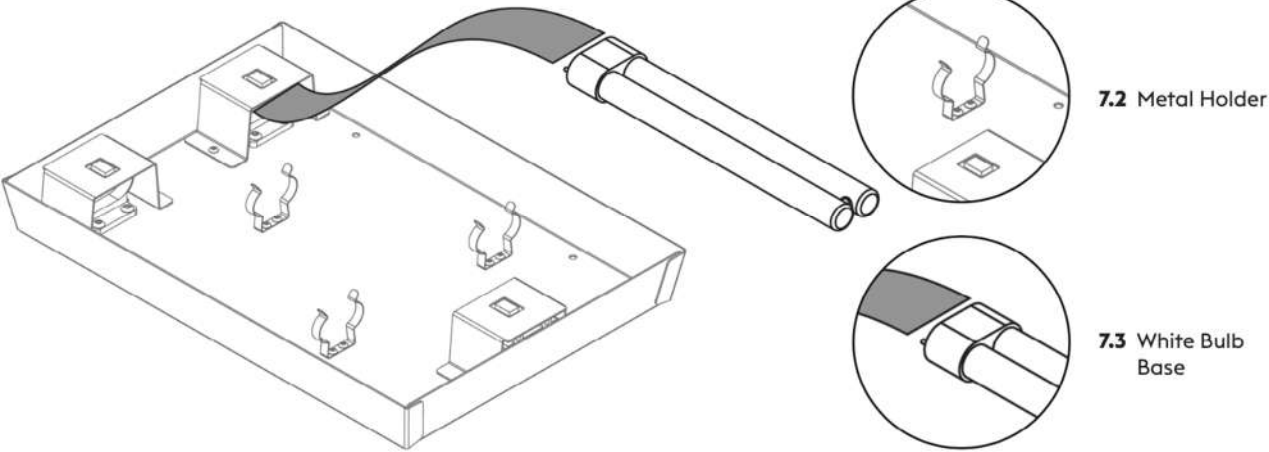

Overhead Unit View

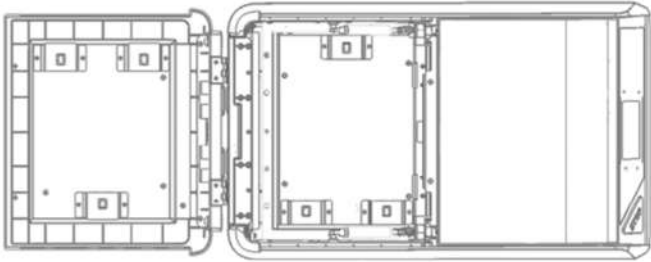

Before - No bulbs inserted

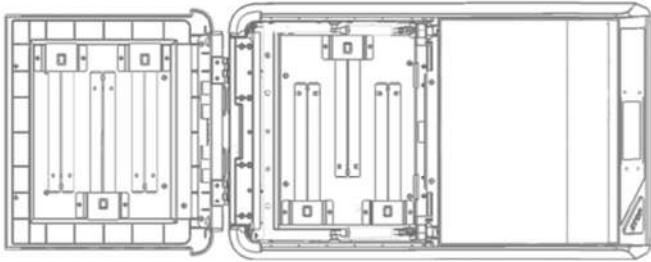

After - With all bulbs inserted

- 8. Once all the bulbs are inserted, close the rear access panel.
- 9. Using the flathead screwdriver provided, rotate the rear latches to lock the rear access panel. *Arrows beside each latch indicate which direction locks and unlocks the rear chamber latches.*

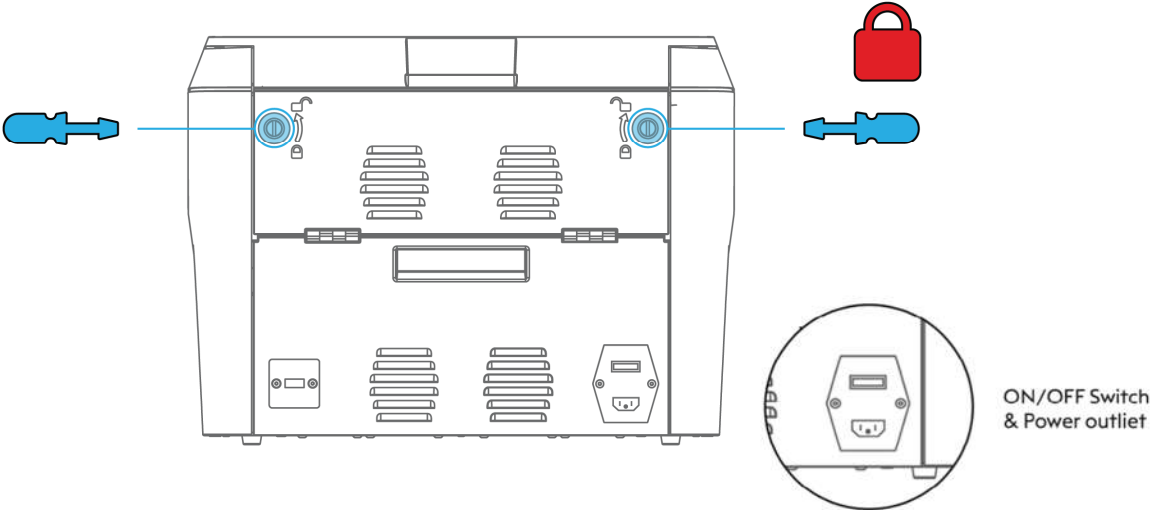

- 10. Ensure that the CleanSlate UV Sanitizer "ON/OFF switch" located on the rear of the unit is set to the "OFF" position.

11. Insert the power cord provided into the CleanSlate UV Sanitizer power outlet and plug it into a three-prong grounded electrical outlet.
12. Toggle the power 'ON' using the "ON/OFF switch" located on the rear of the unit.
13. Once the power is switched on, the lid should open automatically and the LCD screen will display a warm-up countdown for 60 seconds.
14. Once the warm-up countdown has completed, you will notice a gear icon located in the top left-hand corner of the LCD screen.

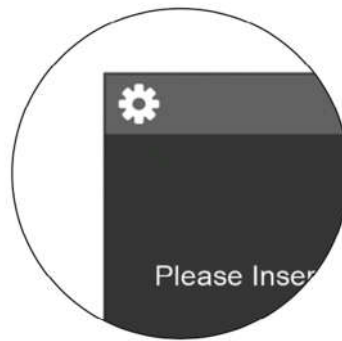

15. Click on the gear icon to bring up the menu. You should apply firm pressure.
16. From the menu, select "Maintenance", then "Glass" and confirm with "Yes".
The tray should move to the rear of the CleanSlate UV Sanitizer unit.
17. Toggle the power 'OFF' using the "ON/OFF switch" located on the rear of the unit.
18. Locate the open slot inside the front compartment of the CleanSlate UV Sanitizer. This is the space below the lid of the front compartment through which you will be inserting the quartz glass in step 22.3.
19. Using the flathead screwdriver provided, rotate the rear latches to unlock and open the rear access panel. *Arrows beside each latch indicate which direction locks and unlocks the rear chamber latches.*
20. Carefully remove the quartz glass from the cardboard box provided.
21. Before inserting the quartz glass into the CleanSlate UV Sanitizer, hold it at an angle with your left hand slightly lower than your right.
22. Insert the glass into the CleanSlate UV Sanitizer by placing it into the front tray by following these steps:
 - 22.1 While standing in front of the unit, carefully insert the quartz glass while holding it at an angle as you place it into the front of the unit.
 - 22.2 Once the quartz glass is inside the unit, lower your right hand so the glass is now level with the bottom of the CleanSlate UV Sanitizer.

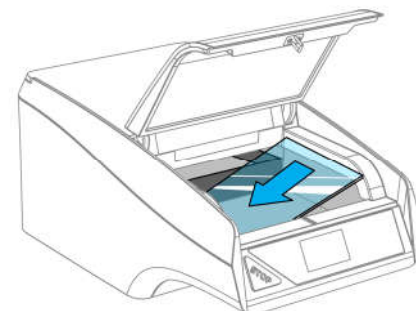
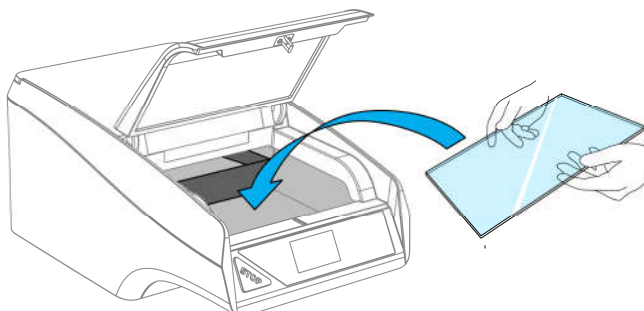

- 22.3 Slowly push the quartz glass into the rear of the device through the open slot inside the front compartment of the device.
- 22.4 When the quartz glass is in the rear of the CleanSlate UV Sanitizer, gently lower it into the tray. *Note: there is a finger access point in the tray to assist with lowering it down.*

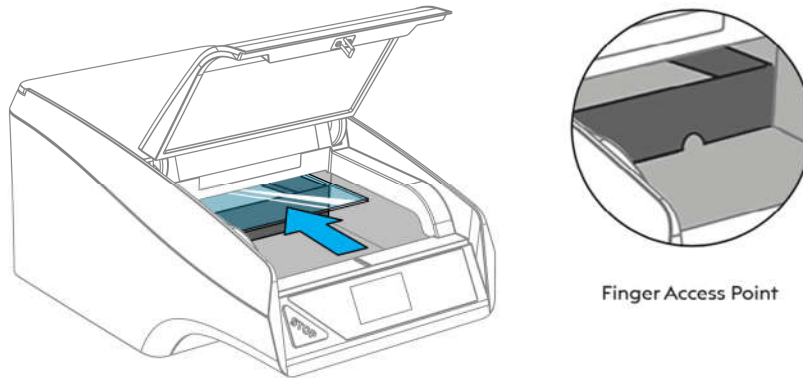

23. Once the glass is inserted, close the rear access panel. Using the flathead screwdriver provided, rotate the rear latches to lock the rear access panel. *Arrows beside each latch indicate which direction locks and unlocks the rear chamber latches.*
24. Toggle the power 'ON' using the "ON/OFF switch" located at the rear of the unit.
25. After the 60 second warm-up cycle is complete, the LCD screen will display "Please Insert Device and Close Lid", indicating that the CleanSlate UV Sanitizer is ready to be used.
26. Run a single cycle by closing the front lid.



Congratulations, your CleanSlate UV Sanitizer is now ready to use! If you see any error messages, please refer to Section C "Troubleshooting" in the user manual or contact us at support@cleanslateuv.com or +1 (877) 553-6778 ext 2.

You can also scan the QR code for quick access to our support page or visit www.cleanslateuv.com/support

B.4 Directions For Use

The CleanSlate UV Sanitizer should only be used to sanitize hard, non-porous items. This includes, but is not limited to, cell phones, tablets, watches, radios, ID badges, and other mobile communication devices/tools.

1. Pre-clean the object before placing it in the device
2. Gently place items in the front tray

Note: If placing multiple items, ensure they are placed within blue lines and are at least 2.5 cm (1 inch) apart.
3. Close the front lid. The sanitization cycle will start automatically.
4. When the cycle is complete the lid will automatically open.

5. Retrieve items.

Note: UV light may accelerate discolouration in plastics

The use of this device is a supplement to, and not a substitute for, standard infection control practices; users must continue to follow all current infection control practices, including those practices related to cleaning and disinfection of environmental surfaces.

B.5 CleanSlate UV Sanitizer Placement

The CleanSlate UV Sanitizer can be placed on any sturdy table, desk, or provided stand. When deciding where to place your CleanSlate UV Sanitizer, please ensure that:

1. There are at least 5 cm (2 inches) of space behind the CleanSlate UV Sanitizer.
2. Nothing is blocking the ventilation ports.
3. The CleanSlate UV Sanitizer is not placed in an environment with an ambient temperature of more than 80°F/32°C.
4. The front of the CleanSlate UV Sanitizer is not overhanging the desk or table and cannot be knocked off by those passing by.

B.6 Lifting the CleanSlate UV Sanitizer

The CleanSlate UV Sanitizer was designed with handles to grip when moving or lifting the device.

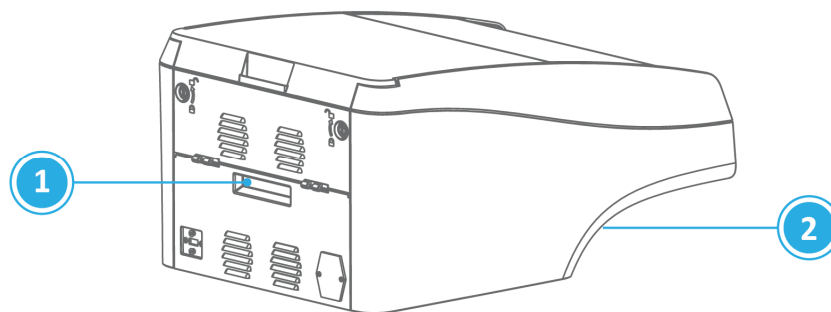

To lift:

- Place one hand or support on the rear chamber handle, as indicated by number 1.
- Place the other hand or support underneath the front lower cover, as indicated by number 2.

C. Troubleshooting

C.1 Regular Stop

Pressing the Stop button will stop the CleanSlate UV Sanitizer at any time during the sanitization cycle, return the tray with the device to the front and automatically open the lid, allowing the user to retrieve the device from the CleanSlate UV Sanitizer. To disconnect the device, please position CleanSlate UV Sanitizer with at least 13 cm (~5 inches) of room in the rear, turn off the power switch, and remove the power cord from the back.

C.2 Device Restart

To restart the device, toggle the power switch on the rear of the device. *Wait 60 seconds for the device to resume normal function.*

C.3 Device Retrieval in Case of Power Failure

In the rare case of a complete and sudden power failure while a device is in the CleanSlate UV Sanitizer, please follow these instructions.

1. Ensure to turn OFF the power switch and unplug the power cord from the CleanSlate UV Sanitizer.
2. Move the CleanSlate UV Sanitizer to allow at least 40 cm (~16 inches) of room behind the rear access panel.
3. Using a coin/flat head screwdriver or a key, unlock the rear latch and open the upper rear panel.



CAUTION: REAR CHAMBER AND/OR TRAY WALLS MAY STILL BE HOT.

4. If the tray is in the rear of the CleanSlate UV Sanitizer, remove your device.
5. If the tray is in-between, gently grab the top of the tray and pull firmly towards the back chamber and remove your device.
6. If the tray is at the front, override the safety lock by placing a thin screwdriver or similar tool into the left-hand side "manual release slot" on the underside of the lower front cover (immediately underneath the LCD screen)

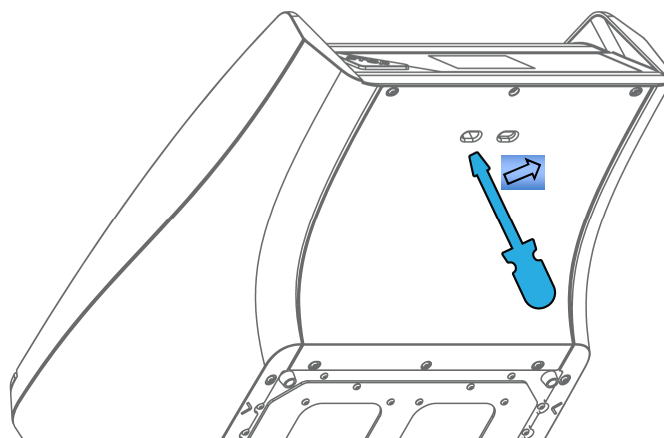

7. Place the tool up into the slot approximately 5 cm (2 in) and to the leftmost side. Push towards the right side and wiggle until the latch is released.
8. The lid will automatically open, and you can retrieve your device(s).
9. Close the rear panel, lock the rear latches using key/coin/flat screwdriver and close the lid.
10. Plug the power cord into the CleanSlate UV Sanitizer, position back the device to the desired position.
11. Turn "ON" the power switch and wait for the power to come back.

C.4 Error Diagnosis

The CleanSlate UV Sanitizer will display an error code to prevent use if the unit is malfunctioning. Follow the table below for diagnostics when an error occurs.

Error 101S

This indicates a mechanical issue. Please check the tray to ensure there are no devices stuck within or around the tray **and ensure the rear foam has been removed**. If there is no interference observed, gently pull the tray towards the front of the device. Restart the device, wait 60 seconds for it to warm-up and close the lid to initiate a sanitization cycle to check for normal functionality. If the error persists, contact CleanSlate UV for assistance.

Error 101M

This indicates the belt is slipping or loose. If the error persists, contact CleanSlate UV for assistance.

Error 101R

This indicates that the rear limit switch is being triggered before the tray reaching the back of the chamber. The device will restart once. If the problem persists, please contact CleanSlate UV for assistance and provide this error code.

Error 101F

This indicates that the front limit switch is being triggered before the tray reaching the front of the chamber. The device will restart once. If the problem persists, please contact CleanSlate UV for assistance and provide this error code.

Error 103

This indicates that the UV chamber is warmer than the allowed limits and lacks proper ventilation. Please ensure that nothing is blocking the ventilation ports in the rear of the device. It must have at least 5 cm (~2 inches) of space away from the wall—power off the unit. After 15 minutes of cooling off, restart the device, wait 60 seconds for it to warm-up and close the lid to initiate a sanitization cycle to check for normal functionality. If the error persists, call CleanSlate UV for assistance.

Error 105

This indicates a bulb error. Power off the device and unplug the power cord. Ensure there is at least 40 cm (16 in) of room behind the rear access panel. Open the rear chamber by using a flathead screwdriver or key to turn and unlock the rear latches. Check that all the bulbs are correctly inserted. If not, use gloves to remove and reinsert all six bulbs. Ensure they are pressed firmly into their respective bulb socket. Close the chamber and power on the device. If the issue persists, call CleanSlate UV for assistance.

Error 106

This indicates an error with the ballasts that control and monitor the UVC bulbs. Please restart the device. If the error persists, call CleanSlate UV for assistance.

Error 107

This indicates that bulb replacement is required. The UV bulbs have reached their end of life, which is expected after six months of continuous use. Call CleanSlate UV to order replacement bulbs.

Error 108

This indicates a bulb error. Power off the device and unplug the power cord. Ensure there is at least 40 cm (16 in) of room behind the rear access panel. Open the rear chamber by using a flathead screwdriver or key to turn and unlock the rear latches. Check that none of the bulbs are broken. If not, use gloves to remove and reinsert all six bulbs. Ensure they are pressed firmly into their respective bulb socket. Close the chamber and power on the device. If the issue persists, call CleanSlate UV for assistance.



CAUTION: Bulbs may be hot! Please wait 5 minutes for cool down before touching.

Error 109

This indicates that bulbs failed less than thirty days before their expiry date and require immediate replacement. Please contact your BioMed team or CleanSlate UV for assistance.

D. Maintenance

D.1 Bulb Replacement

The CleanSlate UV Sanitizer device contains six germicidal UVC bulbs designed to inactivate pathogens. The UVC bulbs have an average lifespan of 4320 hours. The CleanSlate UV Sanitizer will provide a warning when bulbs are one month away from needing replacement and will cease to function after their lifespan has expired. Only utilize CleanSlate UV approved bulbs. The use of unapproved bulbs may deteriorate performance or may cause malfunctions. The use of unapproved bulbs will void the CleanSlate UV warranty.

D.1.a Warnings and Precautions



WARNING: DISCONNECT THE POWER SUPPLY BEFORE BULB REPLACEMENT TO AVOID THE POSSIBILITY OF ELECTRIC SHOCK.



WARNING: DUE TO MERCURY EXPOSURE RISK, TECHNICIANS MUST WEAR NON-POWDERED LATEX GLOVES DURING BULB REPLACEMENT.

D.1.b Bulb Replacement Procedure

For images to support instruction, please refer to “Bulb Replacement Instructions” (3042-0004). This manual is supplied with every set of bulbs purchased. Replacement of bulbs may only be completed by a trained technician.

1. Ensure the CleanSlate UV Sanitizer is in ‘idle’ position with the lid open and “Please Insert Device(s) and Close Lid” message showing.
2. On the LCD touch screen, press the settings icon “⚙️” on the top left corner of the screen, then select “Maintenance,” followed by “BULB”, followed by “YES”.
*Note: you must **press firmly on LCD screen**.*
3. The LCD screen should display the “Please Wait for Bulbs to Cool Down” message along with a countdown.
4. When prompted, turn OFF the CleanSlate UV Sanitizer using the power switch on the rear panel & **unplug the power cord from device.**
5. Ensure there is at least 40 cm (16 in) of room behind the rear access panel. Use a flathead screwdriver to rotate the rear latches, grab the rear handle at the top and open the rear access panel.
6. Wearing the nitrile gloves provided, carefully remove all bulbs (6 total) from **both upper and lower chambers** by pulling the bulb horizontally out of the socket, flexing the metal holders open and lifting the bulb out.
Note: please refer to SECTION D.2 DISPOSAL OF UV BULBS for safe disposal instructions
7. Wearing the nitrile gloves provided, remove germicidal bulbs from the box and install in the device by:
 - a. Placing the bulb base halfway into the bulb socket.
 - b. Flexing the metal holder outwards and pushing the bulb down until the holder snaps over-top of the bulb.
 - c. Grabbing the white base of the bulb and pushing firmly into the bulb socket. You should hear a “click” indicating that the bulbs have snapped in place.
Note: It is normal for this to take several tries.
8. Close the rear access panel and using a flat head screwdriver, rotate the rear access latches to lock the rear access panel.
9. Plug the power cord back into the device and turn “ON” using the power switch on the rear panel.

D.2 Language Selection

1. Ensure the CleanSlate UV Sanitizer is in 'idle' position with the tray at the front and the lid open.
2. On the LCD touch screen, firmly press the settings icon "⚙️" on the top left corner of the screen, then select "Settings," followed by "LANG".
Note: you must press firmly on LCD screen to engage.
3. Select either "Unilingual" or "Bilingual." (Unilingual will display all text on the screen in a single language. Bilingual will display everything on the screen in two languages, changing every 4-5 seconds).
4. When it prompts you to select language, press firmly on the preferred language displayed on right side of screen.
5. The LCD screen will prompt you to turn the CleanSlate UV Sanitizer OFF and ON for updates to be implemented.

D.3 Communication Protocol

Under device settings, there is the option to press "Wi-Fi", "BLE" or "RFID". If you would like to take advantage of these features, please contact CleanSlate UV technical support toll-free at +1 (877) 553-6778 or visit <https://cleanslateuv.com>.

D.4 Disposal of UV-C Bulbs



WARNING: UV BULBS CONTAIN MERCURY (Hg).
Please Manage in Accordance with Local Disposal Laws.
Visit www.lamprecycle.org or call **1-800-555-0050** for information in your jurisdiction.
As a general rule, bulbs containing Mercury are not permitted in solid waste disposal.

D.5 Recycling Resources

CleanSlate UV can assist you with recycling your bulbs. Please contact us by email at support@cleanslateuv.com or call our technical support team at +1 (877) 553-6778 for more details on our recycling program.

D.6 Broken Bulb Procedure

Germicidal bulbs contain a small amount of mercury sealed within the glass tubing. When a bulb breaks, some of this mercury is released as mercury vapor. To minimize exposure to mercury vapor, the following cleanup and disposal steps are recommended.

Before Cleanup

- Have people and pets leave the room
- Air out the room for 5-10 minutes by opening a window or door to the outdoor environment
- Shut off the central forced-air heating/air-conditioning system, if you have one
- Collect materials needed to clean up broken bulb:
 - stiff paper or cardboard;
 - sticky tape;
 - damp paper towels or disposable wet wipes (for hard surfaces); and
 - a glass jar with a metal lid or a sealable plastic bag.

During Cleanup

- **DO NOT VACUUM.** Vacuuming is not recommended unless broken glass remains after all other cleanup steps have been taken. Vacuuming could spread mercury-containing powder or mercury vapor
- Be thorough in collecting broken glass and visible powder. Scoop up glass fragments and powder using stiff paper or cardboard. Use sticky tape, such as duct tape, to pick up any remaining small glass fragments and powder. Place the used tape in the glass jar or plastic bag. See the detailed cleanup instructions for more information, and for differences in cleaning up hard surfaces versus carpeting or rugs
- Place cleanup materials in a sealable container

After Cleanup

- Promptly place all bulb debris and cleanup materials, including vacuum cleaner bags, outdoors in a trash container or protected area until materials can be disposed of. Avoid leaving any bulb fragments or cleanup materials indoors
- Next, check with your local government about disposal requirements in your area because some localities require fluorescent bulbs (broken or unbroken) to be taken to a local recycling center. If there is no such requirement in your area, you can dispose of the materials with your household trash
- If practical, continue to air out the room where the bulb was broken and leave the heating/air conditioning system shut off for several hours

If you have further questions, please call your local poison control center at 1-800-222-1222 or CleanSlate UV at +1 (877) 553-6778.

D.7 Quartz Glass

CleanSlate UV Sanitizer device uses quartz glass to support the devices to be sanitized. Quartz glass is highly transparent for UVC light.

If quartz glass is damaged, please contact CleanSlate UV technical support toll-free at **+1 (877) 553-6778** or visit **<http://cleanslateuv.com>**.

E. Cleaning

Periodic cleaning of the CleanSlate UV Sanitizer is recommended to ensure the tray and glass are free from dust and soil to maximize UV effectiveness. Ensure the power is turned OFF before cleaning the device.

E.1 Internal

Turn OFF the device using the power switch on the rear panel. Dampen a microfiber cloth with water, using it to wipe the internal tray walls and the glass. If there is significant **soil or bioburden on the glass**, clean the glass using alcohol-based or bleach wipes before wiping down with a cloth.

E.2 External

External casings and front LCD screen can be cleaned using a damp cloth or commercially available cleaning solutions such as alcohol, bleach or hydrogen-peroxide based wipes. To clean the lid, turn OFF the device and close lid first to facilitate easy cleaning. For daily/frequent cleaning, it's recommended to use *Cleancide* germicidal wipes or *Oxivir* hydrogen peroxide wipes.

F. Specifications and Accessories

F.1 Performance and Technical Specifications

Performance	Model Number	CSUV-UG6CX
	Sanitation Cycle	20 seconds
	Power ON	24/7
Physical Dimensions	Lid closed	L 68cm x W 42cm x H 31.3cm (L 26.7" x W 16.5" x H 12.3")
	Lid open	L 68cm x W 42cm x H 53.9cm (L 26.7" x W 16.5" x H 21.2")
	Weight	17kg (37lb)
	Tray Dimensions	L 24cm x W 32.7cm x H 8.8cm (L 9.4" x W 12.87" x H 3.45")
Environmental	Operating Temperature	5°C / 41°F to 40°C / 104 °F
	Humidity	50% @ 40°C / 104°F – 81% @ 31°C/88°F
	Noise	< 35dB
	Pressure	Atmospheric (101.3 kPa)
Electrical	Voltage	100 - 240 V, 3A, 50/60Hz
	Power Consumption – Idle	100W (idle), 130W (cycle)
	Fuse	5x20mm 3A 250V
Bulbs	Germicidal UV-C bulbs	Six (three upper and three lower)
User Interface	Lid Open	Automatic
	Touch Screen	Yes (Resistive)
	Cycle Abort (Stop Button)	Yes
Miscellaneous	Initial Warm-up time	60 seconds
Regulatory	Electrical Safety	IEC 61010-1
	Emission (EMI/EMC)	Class A limits of IEC 61326, FCC Part 15 Subpart B and ICES-003
	Wireless Transmitter	FCC and CE certified
	CE Marking	Yes
	RoHS Compliant	Yes

F.2 Replacement Parts and Accessories

Item	Product Description	CleanSlate Product Ref #
UV Bulbs (pack of 6)	6 x CleanSlate UV Sanitizer compact germicidal bulb	CSUV-AB6X
Power Cord	1 x 2.4 m (eight-foot (8ft)), three-pronged power cord	CSUV-AP1Y
Gas Springs	2 x Easy-to-replace gas springs for CleanSlate UV Sanitizer lid	CSUV-AS2YJY
Stationary Stand Accessory	1 x custom stand to support the CleanSlate UV Sanitizer	CSUV-AT1Y
Rolling Stand Accessory	1 x custom rolling stand to support the CleanSlate UV Sanitizer	CSUV-AR1Y

G. Customer Support and Warranty

G.1 Contact Info

Phone: +1 (877) 553-6778
Technical Support: Ext. 2
Ordering or Sales: Ext. 1
Online: www.cleanslateuv.com
Email: support@cleanslateuv.com
Mailing Address: CleanSlate UV
123 Edward St, Suite 209 Toronto ON M5G 1E2

G.2 Limited Warranty

CleanSlate Technologies Incorporated provides the following limited warranty. This limited warranty extends only to the original purchaser. CleanSlate UV warrants this product and its parts against defects in materials or workmanship for **one-year labor and parts** from the original ship date. During this period, CleanSlate UV will repair or replace defective parts with new or reconditioned parts at CleanSlate UV's option, without charge.

Shipping fees incurred from returns for under-warranty service in the first 120-days will be paid by CleanSlate UV. All shipping fees both to and from CleanSlate UV following this 120-day period must be paid for by the customer, and the customer is liable for any damages resulting from improper handling during shipping. All returns, both during and following the 120-day period, must be affected via the Procedures for Obtaining Warranty Service described at www.cleanslateuv.com/warranty/.

All original parts (parts installed by CleanSlate UV during the original system build) replaced by CleanSlate UV, an authorized servicing agent, or an authorized service center, become the property of CleanSlate UV. Any after-market additions or modifications will not be warranted. The owner is responsible for the payment, at current rates, for any service or repair outside the scope of this limited warranty.

CleanSlate UV makes no other warranty, either express or implied, including but not limited to implied warranties of merchantability, fitness for a particular purpose, or conformity to any representation or description, with respect to this product other than as set forth below. CleanSlate UV makes no warranty or representation, either express or implied, with respect to any other manufacturer's product or documentation, its quality, performance, merchantability, fitness for a particular purpose, or conformity to any representation or description.

Except as provided below, CleanSlate UV is not liable for any loss, cost, expense, inconvenience or damage that may result from use or inability to use the product. Under no circumstances shall CleanSlate UV be liable for any loss, cost, expense, inconvenience or damage exceeding the purchase price of the product.

The warranty and remedies set forth below are exclusive and in lieu of all others, oral or written, expressed or implied. No reseller, agent or employee is authorized to make any modification, extension or addition to this warranty.

Warranty Conditions

The above Limited Warranty is subject to the following conditions:

1. This warranty extends only to products distributed and/or sold by CleanSlate UV or an authorized agent. It is effective only if the products are purchased and operated in North America.
2. This warranty covers only the normal use of the device as outlined in the user manual and via instructions on the CleanSlate UV Sanitizer device. CleanSlate UV shall not be liable under this warranty if any damage or defect results from (i) misuse, abuse, neglect, improper shipping or installation; (ii) disasters such as fire, flood, lightning

or improper electric current; or (iii) service or alteration by anyone other than an authorized CleanSlate UV representative or someone being instructed by an authorized CleanSlate UV representative; (iv) damages incurred through irresponsible use, including those resulting from the improper use of solvents, detergents or other non-recommended practices.

3. You must retain your bill of sale or other proof of purchase to receive warranty service.
4. No warranty extension will be granted for any replacement part(s) furnished to the purchaser in fulfillment of this warranty.
5. CleanSlate UV and its Authorized Service Centers accept no responsibility for any data or information stored on any media or any parts of the products returned for repair to CleanSlate UV.
6. This warranty may be considered void if the use of spare parts, **including but not limited to non-authorized UV bulbs**, are supplied by anyone other than CleanSlate UV or an authorized agent.
7. Bulbs and fuses are not covered for replacement or repair after the first 30 days under the limited warranty.

H. Frequently Asked Questions

1. What is the efficacy of the CleanSlate UV Sanitizer against different types of pathogens?

The CleanSlate UV Sanitizer has been validated by third-party labs to achieve pathogenic kill rates ranging from 99.9% to more than 99.99%, depending on the pathogen. Please get in touch for detailed efficacy documentation.

2. What types of devices can go into the CleanSlate UV Sanitizer?

The CleanSlate UV Sanitizer should only be used to sanitize non-critical devices, equipment and personal devices with hard, non-porous surfaces. This includes, but is not limited to, cell phones, tablets, ID badges, and other mobile communication devices.

3. How does the CleanSlate UV Sanitizer sanitize devices?

The CleanSlate UV Sanitizer uses UVC light (254nm) to kill or inactivate microorganisms by destroying nucleic acids and disrupting their DNA, leaving them unable to perform vital cellular functions.

4. Should the devices be cleaned before sanitization?

Germicidal UVC light will not penetrate through the soil or dirt. Therefore it is highly recommended to clean or wipe down the devices to be sanitized before placing them in the CleanSlate UV Sanitizer. Cleaning is not sanitization, and sanitization is NOT cleaning.

5. How is the user affected by repeated use of the CleanSlate UV Sanitizer?

None, as the CleanSlate UV Sanitizer's design, ensures complete enclosure of the sanitization chamber that prevents users from being exposed to UV-C light.

6. Can children use the CleanSlate UV Sanitizer?

The CleanSlate UV Sanitizer is classified as lab equipment and should not be used by those under 14.

cleanslate 