

2019-3942
2019-11-06

LABEL – CONTROLLER/CELL

ECO-matic MEMS16USA Automatic

**CHLORINE GENERATOR
DEVICE
CONTROLS BACTERIA AND ALGAE
In
Swimming Pool (Spa) Waters**

COMMERCIAL

A maximum of 20,000 L of water can be treated with one ECO-matic MEMS16USA Automatic Chlorine Generator.
Maximum output of hypochlorous acid equivalent to 0.41 kg of free available chlorine per day

For swimming pools, a range of 1-3 ppm of free available chlorine must be maintained.
For spas, a range of 3-5 ppm of free available chlorine must be maintained.

**READ THE LABEL AND OPERATING MANUAL BEFORE USING
KEEP OUT OF REACH OF CHILDREN
REGISTRATION NO. 30299 *PEST CONTROL PRODUCTS ACT***

WARNING: operating the unit without water flow through the cell can cause a build up of flammable gases which can result in **FIRE OR EXPLOSION**.

Do not use this device with bromide products.

NOTICE TO USER: This pest control product is to be used only in accordance with the directions on the label. It is an offence under the Pest Control Products Act to use this product in a way that is inconsistent with the directions on the label.

Davey Water Products Pty. Ltd
6 Lakeview Drive
Scoresby, Victoria 3179
Australia 61 397 309 232

IN CANADA, CONTACT:
Alpine Spa Covers
2103 – 43rd St
Vernon, BC V1T 6K7
1-800-667-9707

LABEL – CONTROLLER/CELL

Replacement Cell for ECO-matic MEMS16USA Automatic Chlorine Generator
or ECO-matic MEMS36USA Automatic Chlorine Generator

Replacement cell for the chlorine generating device ECO-Matic MEMS16USA Automatic
Chlorine Generator REGISTRATION NUMBER 30299 or ECO-matic MEMS36USA Automatic Chlorine Generator
REGISTRATION NUMBER 30295 *PEST CONTROL PRODUCTS ACT*.

This cell must only be used on this model of chlorine generating device.

Do not use this device with bromide products.

Read the Label, the Installation Manual and Operation Manual of the chlorine generating device ECO-matic
MEMS16USA Automatic Chlorine Generator or ECO-matic MEMS36USA Automatic Chlorine Generator

Davey Water Products Pty. Ltd
6 Lakeview Drive
Scoresby, Victoria 3179
Australia 61 397 309 232

IN CANADA, CONTACT:
Alpine Spa Covers
2103 – 43rd St
Vernon, BC V1T 6K7 1-800-667-9707



INSTALLATION & OPERATION INSTRUCTIONS

**For Commercial Model
ECO-matic MEMS16USA Automatic
Chlorine Generator**

**For Davey Water Products Pty Ltd, Australia
P/N401730**

Table of Contents

	PAGE		PAGE
Table of Contents / Packing list	3	Installation Trouble Shooting	16
Important Safety Instructions	4	Understanding the ECO-matic System	16
Overview of the ECO-matic system	5	Controls & Display Panel	18
Your ECO-matic Equipment	5	Start Up	18
Installation Summary	5	Digital Display	19
The Components of your ECO-matic	6	Indicators - What They Mean	20
Before Installing your ECO-matic	7	Operation	20
Choosing the "CELL" Location	7	Stand-by Indicator	20
Dual Cell Install / Installing the "CELL HOUSING"	7	Flow Indicator	20
"Backup" Sanitation	9	System Control (Output Control)	20
Installing Flow Meter / Min. Flow Rates	9	Low Salinity Indicator and Cut-Out	21
Installing the Salt-Pro Anode	9	Winter Mode	21
Installing the "POWER SUPPLY"	10	Gas Sensor	21
Connecting the "POWER SUPPLY" to line voltage	10	Shocking the Pool	22
Hard Wiring the "POWER SUPPLY"	10	Maintenance of your ECO-matic	22
Bonding Lug Connection	11	Cleaning the cell	23
Connecting "CELL" to "POWER SUPPLY"	12	Water Chemistry: Salt	24
Connecting "CHEMISTRY SENSOR"	12	Water Chemistry: Stabilizer/Other Levels	25/26
Electrical Connection	14	Possible Chemical Problems	26
Adding Salt to the Pool	15	Trouble Shooting	27
Installation Check List	16	Warranty Details	27
		Template	29
		Installation Diagram/voltage selection	30

Packing List

PART	QTY
POWER SUPPLY	1
CELL (Including plastic Housing)	1
PACK (Mounting Screws, Wall plugs & spare fuses)	1
SaltPro-2	1
INSTALLATION & OPERATION MANUAL	1
Flow Meter (Optional)	1

Important Safety Instructions

1. "WARNING: To reduce the risk of injury, do not permit children to operate this device."
2. "WARNING: heavy pool (or spa) usage, and higher temperatures may require higher chlorine output to maintain proper free available chlorine residuals."
3. "If additional chlorine is required due to heavy bather loads, use sodium hypochlorite (liquid chlorine) to maintain an appropriate chlorine residual in the water."
4. "Maintaining high salt and chlorine levels above recommended range can contribute to corrosion of pool or spa equipment."
5. "DO NOT add pool or spa chemicals directly to the skimmer. This may damage the cell."
6. "Check the expiry date of the test kit as test results may be inaccurate if used after that date."
7. "The life expectancy of the electrolytic cell is 8700 hours under normal use conditions."
8. "When replacing the cell, only use replacement cells having a label that clearly states that it is a replacement cell for the chlorine generating device ECO-matic MEMS16USA Automatic Chlorine Generator, REGISTRATION NUMBER 30299, *PEST CONTROL PRODUCTS ACT*."
9. "Follow all aspects of the local and National Electrical Code(s) when installing ECO-matic MEMS16USA Automatic Chlorine Generator."
10. "NOTE: For outdoor pools, chlorine residuals can be protected from destruction by sun light by addition of stabilizer (cyanuric acid).
11. "For proper sanitation, spas must be completely drained periodically. The number of days between COMPLETE SPA DRAINAGE is equal to the volume of spa water in litres, divided by 10 times the maximum number of daily spa users. Refill spa with water and repeat DIRECTIONS FOR USE of the device."
12. Do not use this device with bromide products.

Health and Hyperthermia warnings for spas:

1. "People with a medical condition should consult a physician before entering pool or spa water."
2. "Maximum spa water usage temperature is 40°C. Bathing in spa water at 40°C should not exceed 15 minutes."
- 3.

When installing and using this electrical equipment, basic safety precautions should always be followed, including the following:

1. READ AND FOLLOW ALL INSTRUCTIONS
2. A green colored terminal or a terminal marked G, GR, Ground, Grounding, or the international ground symbol is located inside the power control box ('power supply'). To reduce the risk of electric shock, this terminal must be connected to the grounding means provided in the electric supply panel with a continuous copper wire equivalent in size to the circuit conductors supplying this equipment.
3. At least two lugs marked 'Bonding Lugs' are provided on the external surface or on the inside of the power control box ('power supply'). To reduce the risk of electric shock, connect the local

common bonding grid in the area of the hot tub or spa or pool to these terminals with an insulated or bare copper conductor not smaller than No. 6 AWG.

4. SAVE THESE INSTRUCTIONS

Welcome to the luxury of a salt water swimming pool

We are dedicated to providing you with the most luxurious pool water you have ever experienced, as well as the most reliable product and solid after-sales service you could hope for.

Reading this Guide will help ensure that your ECO-matic generator functions correctly and efficiently, help avoid the expense of unnecessary service calls and make you aware of certain maintenance procedures which, if left undone, may void warranties offered by the manufacturer. Please refer to the Trouble-Shooting section of this Guide before calling your dealer.

Overview of the ECO-matic Salt Water Pool System

When salt dissolved in pool water and then subjected to simple electrolysis (by way of the in-line ECO-matic 'Cell'), the chloride portion of the salt (sodium chloride) is transformed into an effective sanitizer,* which has the ability to oxidize (kill) bacteria, algae and other such organics which would otherwise flourish in the water. This process recycles, so it does not consume the salt, which is simply used over and over again.

Sized to suit your particular pool or spa, your ECO-matic system will provide the sanitizer necessary to maintain your pool/spa water by using and recycling a natural product – salt. Your ECO-matic will do exactly the same thing as 'pool chlorine' would do.

*(HOCl the same effective sanitizer as would result if 'pool chlorine' was added to the water – but without the unpleasant aspects of chlorine compounds and without the need to handle them.)

Your ECO-matic Equipment

When correctly installed, your ECO-matic will operate **ONLY WHEN THE FILTER PUMP IS OPERATING** and water is flowing through the 'Cell'. Your ECO-matic must **NOT** be able to operate while the filter pump is OFF. If your ECO-matic continues to operate after the filter pump is switched OFF (as indicated by bubbling and cloudiness at the 'Cell'), **turn it off immediately**, contact your ECO-matic Dealer or the person who installed your ECO-matic immediately and ensure that the fault is rectified.

Installation Summary

This is a quick guide as to how the ECO-matic should be installed. Refer to the following pages for detailed instructions and helpful hints.

1. Install the ECO-matic 'Cell' into the return line, downstream from all other equipment. The 'Cell' must be horizontal. The water flow direction through the cell housing should be 'flowing away from the Cell Head'. Inlet and outlet piping to be a minimum of 15cm (6") in length (to provide for easy Cell Housing replacement if this becomes necessary in the future). Refer to following pages for details.
2. Mount the power supply onto a wall, etc., within reach of the 'Cell' cord. Connect to power so that power supply receives power only when the filter pump is operating (both components should switch on and off coincidentally). Refer to following pages for important wiring instructions.
3. Connect 'Cell' to power supply. Refer to following pages for connection details.
4. Add salt to the pool water.

The Components of your ECO-matic

The Power Supply

The power supply (or Power Control) contains the electrical components which transform the mains power supply to the low voltage DC current required to operate the ECO-matic 'Cell', as well as the other various operating and control functions of the ECO-matic system.

The 'Cell'

The ECO-matic 'Cell' is the component which comes into contact with the pool/spa water and which, through a process of electrolysis, produces (from the 'natural' salt dissolved in the water) the sanitizer/oxidizer necessary to maintain the water in a healthy condition. The 'Cell' is comprised of sophisticated materials specifically designed and engineered for ECO-matic's intended purpose.

SaltPro Annode

An in-line zinc anode called SaltPro should be installed in-line and will serve as a sacrificial component. Provided with a bonding lug and an air release valve. Housed in a 5cm (2") slip tee with clear PVC for visual inspection.

Flow Meter

A **flow meter must be installed** into the cell line to verify correct flow. This can be purchased with the ECO-matic or supplied separately by the ECO-matic dealer.

The Salt

A basic ingredient of the ECO-matic process is SALT (nature's own salt, pure evaporated ocean salt, or table salt – sodium chloride). The salt is added directly into the pool or spa water to produce the water salinity required to enable your ECO-matic to function properly. Salt is available at most pool supply stores, home improvement centers, hardware stores, etc, usually in 18kg (40 lb), 22.5kg (50 lb), or 36kg (80 lb) bags. Be sure to use 'sodium chloride' and not 'potassium chloride'. Salt must not contain: anti-caking agent, soda salt, yellow prussiate of soda, iodized salt, potassium chloride, or road salt. **Recommended salts: Medium/fine grade granular kiln dried solar salt; mill grade salt At 99.4% pure NaCl**

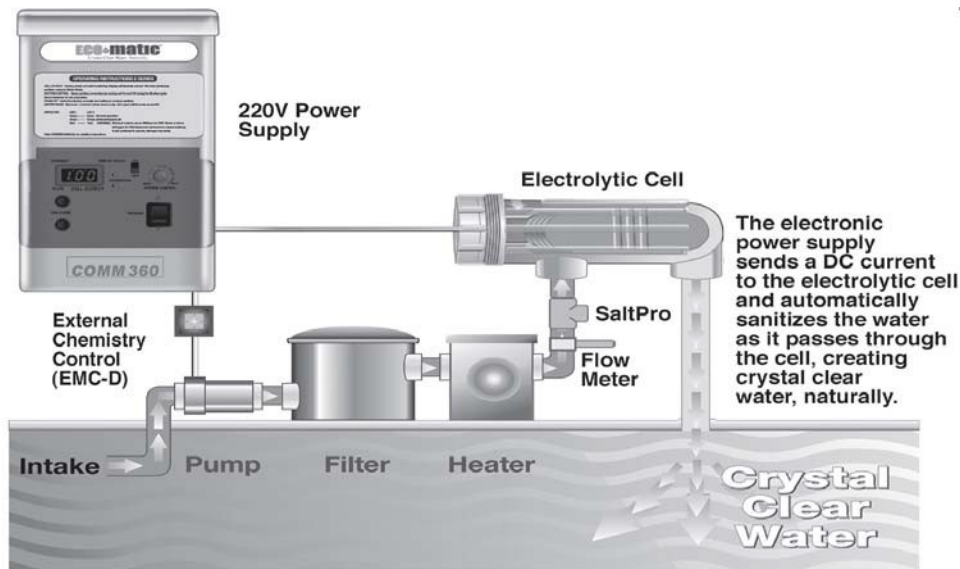

Before Installing Your ECO-matic...

Choosing the 'CELL' Location

The location in which the 'Cell' is to be installed is important. The 'Cell' must be located as follows:

- * In the return-to-pool line (the pipe carrying filtered water back to the pool)
- * AFTER (down-stream from) all other equipment (filter, heater etc)
- * Locate the 'Cell' so that its power supply cord (attached to power supply) can reach the 'Cell' from the 'Power Supply' location.
- * The 'Cell' cord must be at least 1.5 m (5 ft) distance from the inside walls of the pool/spa (at least 1.5m (5 ft) from the nearest water in the pool/spa).

Other considerations regarding 'Cell' location:

When correctly installed, the 'Cell' will produce sanitizer only when water is flowing through it – and, obviously, the sanitizer is carried in the water, to wherever the water is being directed

IMPORTANT: Refer to your ECO-matic Owner's Guide for important instructions – how to prevent over-production of sanitizer.

If there is a solar heater attached to the pool, locate the 'Cell' so that it has water flowing through it whenever the filter pump is operating regardless of whether water is flowing through the solar heater panels. Flow through each of the cells should be .09-.19 CBM (25-50 GPM) and plumbed to reduce the potential for cavitation in the cell.

Dual Cells Installation

- Saltline USA recommends that a maximum of TWO cells be used per body of water
- Installing more cells will impact the warranty
- Cells should be installed in parallel ONLY

See diagram on page 31 of this manual for dual cell layout.

Installing the 'CELL HOUSING'

Once the correct location for the 'Cell' has been established, the 'Cell Housing' must be installed into the plumbing at that selected location. The clear plastic 'Cell Housing' is PVC compatible, so use ordinary PVC solvent (glue) to attach the 'Cell Housing' to the plumbing. **Remove the 'Cell' from the 'Cell Housing' before attempting to install the 'Cell Housing'.**

IMPORTANT The 'Cell Housing' must be installed as follows:

- * 'Cell Housing' must be installed in a HORIZONTAL position.
- * Water flow should be in the direction indicated by the ARROW on the clear plastic 'Cell Housing' (in the direction flowing away from the 'Cell' head).
- * The Inlet and outlet pipes must be pointing vertically DOWN, to form an inverted 'U' configuration with the 'Cell Housing'.
- * The vertical inlet and outlet PVC piping must be a minimum of 15cm (6") in length (refer Sketches 3a, 3b)
- * The 'Cell Housing' shall be free standing and not secured to any rigid backing surface (such as a wall).
- * Installation should allow easy removal of the cell from the housing.
- * Saltline USA recommends using unions on each of the legs of the cell so that the cell housing can be replaced if required.

Water Flow: In most cases for 5cm (2") PVC the total water flow can be directed through the 'Cell Housing' (as shown in Sketch 3a) without significantly affecting the flow rate and/or back-pressure on the filter etc. However, if flow rate is a concern (high horse-power pump, large diameter piping etc), the 'Cell' can be installed on a by-pass (as shown in Sketch 3b). Note the need for a valve to ensure a correct flow of water through the by-pass.

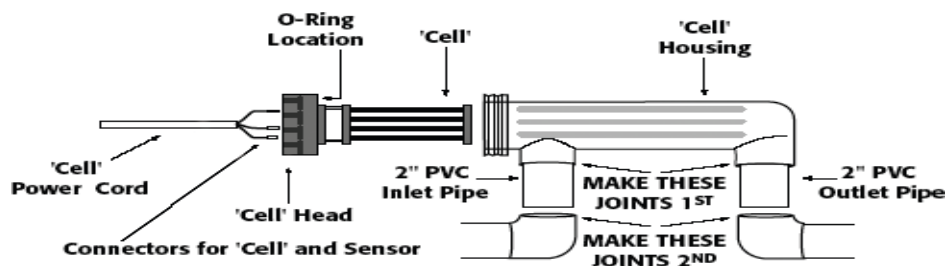

SKETCH 2

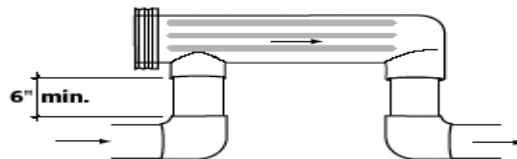

SKETCH 3a

Total flow through 'Cell'

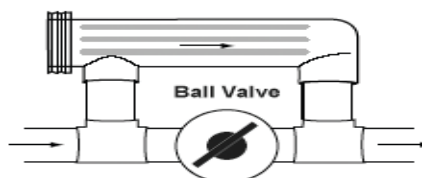

SKETCH 3b

'Cell' on a by-pass
(partial flow through 'Cell')

Helpful HINT: When attaching the 'Cell Housing' into the plumbing, attach the inlet and outlet pipes to the 'Cell Housing' FIRST – and then connect that assembly to the rest of the plumbing (Refer Sketch #2). The inlet and outlet pipes should be pushed in, twisted, and held firmly in place until the PVC solvent holds.

Note: While making these joints, hold the 'Cell Housing' horizontally, with the inlet and outlet pointing down, so that the liquid PVC solvent does not run into the 'Cell Housing' where it will look unsightly through the clear plastic.

Helpful HINT: Copper Pipes? Use PVC 'Flow-Lock' fittings (compression fittings) for easy connection of PVC to copper pipes.

Back - up Sanitation

In the event of a system failure or during periods of extreme bather loads and/ or very hot weather, or due to local authority regulations, extra chlorine may be required to maintain sanitation levels in the pool. Use Sodium Hypochlorite (Liquid Chlorine) as an additional source of chlorine

The extra chlorine can be provided by a dual ORP Chemistry Controller, a simple chlorine injection device such as a chlorine pump/feeder, or by simply keeping enough chemical chlorine on hand to manually cope with an emergency. It is **not recommended** to manually feed chlorine into a commercial pool.

Remember that the Electrolytic Cell will need to be replaced/ re-conditioned periodically and this may mean a small amount of down - time for the system.

Minimum Flow Rates for Optimum Cell Efficiency:

The following flow rates through the cell are recommended for optimum efficiency:

Model	Flow Rate		Approx. Pressure Drop	
	Liters per Minute	Gallons per Minute	KPa	PSI
ECO-matic MEMS16USA Automatic Chlorine Generator	95-190	25 - 50	3	0.4

Testing Cell Flow Rate:

A flow meter must be installed into the cell line to verify correct flow.

A Rolachem flow meter 5cm (2") or equal should be installed into the cell line. Install the flow meter per manufacturer's instructions on the 5cm (2") line leading to the electrolytic cell or cells.

SALTPRO PLUMBING

An in-line zinc anode called SaltPro should be installed in-line and will serve as a sacrificial component. It is housed in a 5cm (2") slip tee with clear PVC for visual inspection.

Models: ECO-matic MEMS16USA Automatic Chlorine Generator – 5cm (2") slip tee

Location:

The SaltPro should be glued in the bypass line prior to the electrolytic cell. Install one SaltPro per each body of water. The anode itself shall have a permanently attached bonding lug which shall be connected to the main bonding loop with a #8 bonding wire.

The SaltPro is fitted with a manual bleeder valve for the installer to ensure, post installation, that the air is removed from the tee and the zinc makes contact with the water flow

Installing the Power Supply

Location of the power supply: Select a location to mount the power supply onto a wall or other suitable location as follows:

- The 'Cell' location should already have been selected (see above). The 'Cell' power cord must reach the 'Cell' (with sufficient slack to allow removal of the 'Cell' from the 'Cell Housing').
- Locate the power supply so its cord is within reach of the point where it is to be connected to main power supply of the circulation pump
- The power supply is weather-proof so it can be located outdoors.
- It is important to ensure that power supply be located in a well ventilated area – and that air can circulate between the back of the power supply and the surface onto which it is mounted (stand-offs on back of power supply provide ventilation for wall-mounted units).
Once a suitable location for the power supply has been selected, use 2 - #8 screws to attach power supply to a wall, fence or post etc (using wall plugs if necessary).
See actual size template on back page for mounting screw position.

Connecting "Power Supply" to Power Supply (Line Voltage)

IMPORTANT: It is essential that your ECO-matic gets power ONLY WHEN THE FILTER PUMP IS 'ON' and water is flowing through the 'Cell'. The power supply to the ECO-matic power supply must therefore be controlled by the same switch or timing device which controls power to the filter pump.

Voltage - Your ECO-matic power supply has been designed to operate on 220/240v AC.

Cord Connected Power Supplies - UL and C-UL Listed power supplies will not be fitted with a power cord. Refer to "Hard Wiring Power Supply" below.

Power supplies with cords should be connected as follows - Cord wires will generally be BLACK, WHITE and GREEN, or BROWN, BLUE and GREEN.

For 220/240V units, connect Black and White or Brown and Blue to load, Green to Ground.

Simply put, the power supply cord wires should be connected to the same terminals as the filter pump – to insure that the power supply receives the same voltage as the filter pump, and is switched ON and OFF coincidentally with the filter pump.

For Hard Wiring Power Supply. (refer Sketch 4 on page 11)

Refer to IMPORTANT SAFETY INSTRUCTIONS at front of these instructions.

De-energize power supply circuit before connection to power supply.

Remove the 'knock-out' in the base of the power supply (if not already removed). The knock-out hole size will suit a standard conduit fitting.

Open the power supply (see instructions below), remove attached cord if necessary and connect replacement power supply wires to terminal block and GROUND terminal (marked with standard GROUND symbol).

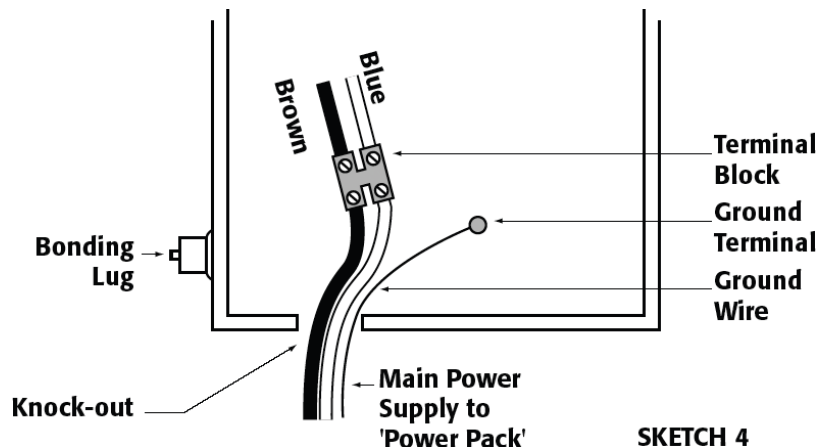

Bonding Lug Connection

The power supply comes with Bonding Lugs (in Canada two Bonding Lugs located externally on the side of the power supply) they must be connected to the local common bonding grid (which includes all metal parts of the swimming pool structure and to all electrical equipment, metal conduit and metal piping) in the area of the equipment, using either insulated or bare #8 AWG copper conductor.

Opening The Power Supply (refer Sketch 5 on Page 12)

Always de-energize power supply circuit before opening power supply.

To open power supply remove the 2 screws which hold removable panel in place. Remove the panel and loosen the single screw inside the recess. The front panel of the power supply can now be removed by a) pulling bottom of front panel out (towards you), then b) slide the front panel down (so front of front of top panel slides out from under top panel).

When opened, the front cover of the power supply should be supported, so as not to put any strain on internal wiring, by connecting the front cover to the left hand side panel of the power supply, using the clip provided (refer Sketch 5).

When replacing the front panel, be sure that all internal wiring is clear of the side and bottom panels, to allow proper seating of the front panel. Insert sides of front panel into the slots at each side, slide the front panel UP so its top edge slides under the top panel. When the front panel is in place, re-tighten screw and replace cover plate.

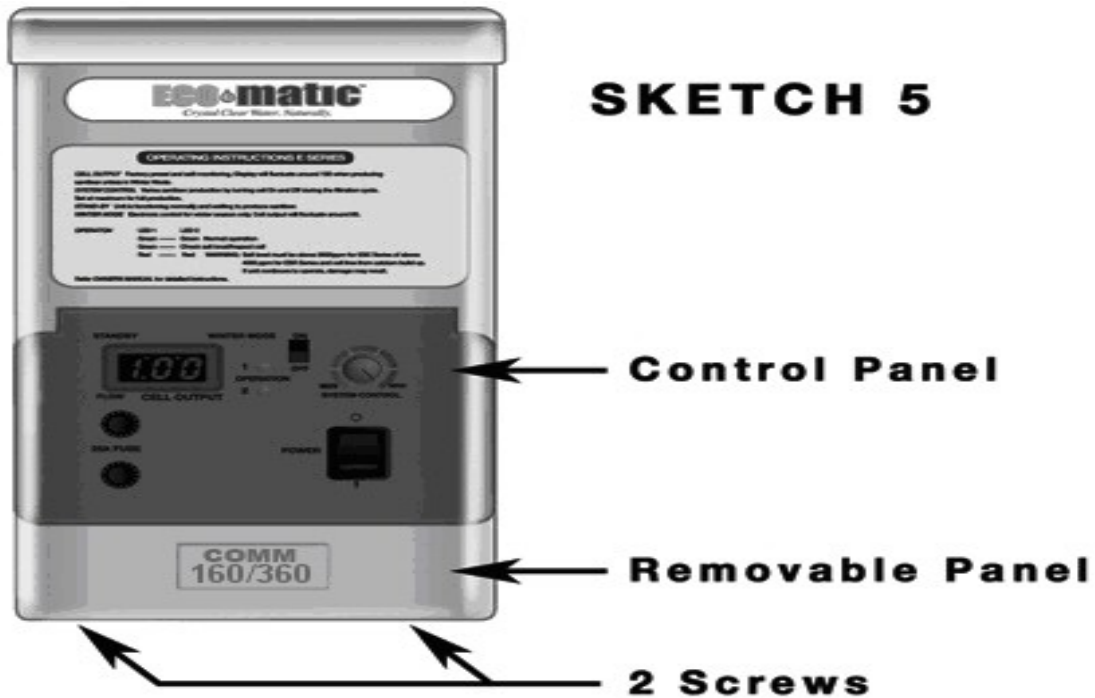

Connecting 'Cell' to Power Supply

The 'Cell' connecting lead is factory-attached to the power supply, with connectors at the end of the lead for attachment to 'Cell' head. Fit the BLACK connectors to either titanium rod. Ensure the connection is snug. The BLUE Flow Sensor should be pushed onto the threaded shaft of the small bolt.

Connecting a Chemistry Controller (ORP) to Power Supply

Plugging the ECO-matic directly into a Chemistry Controller will void the ECO-matic warranty. This connection must be done through a low voltage switch which is an optional item available through your dealer when ordering your ECO-matic unit.



Electrical Connection

EcoMatic® Salt Water Pool System

Example of Wiring Small COMM Series - 220 Volts

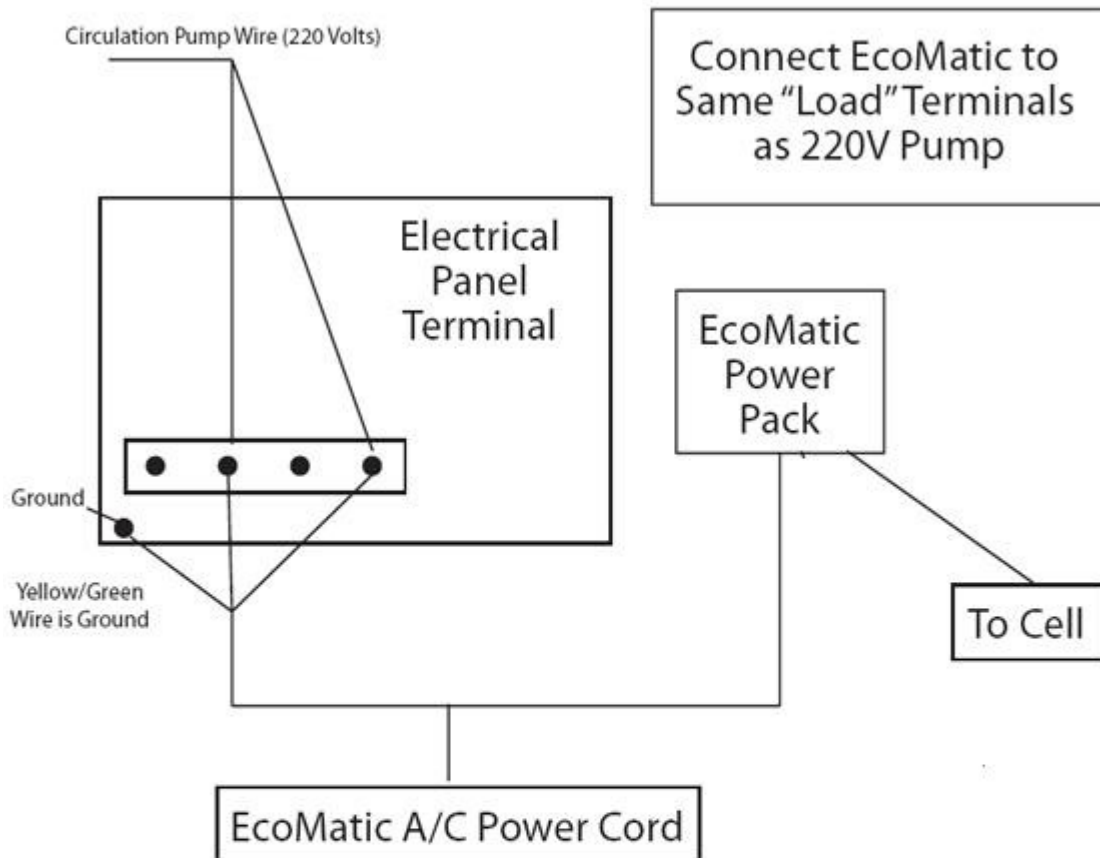

- In the above case, CONNECT EcoMatic to SAME "LOAD" TERMINALS as 220 Volt Pump.
- The "BLACK & WHITE or BLUE & BROWN" WIRES ARE LOADS WHEN WIRING to 220 VOLTS. The "Black or Brown" are loads when wiring to 220 volts. The "Black or Brown" are loads , and the Blue or White" are neutral when wiring to 110 Volts
- For pool control systems: Connect on "Load Side" of pump relay
- EcoMatic unit must be "on Only when the pump is "ON"
- POWER WIRE to time clock may be "hard-wired" to lengthen.

Adding Salt to Your Pool

Your ECO-matic requires a minimum water salinity of 4000 ppm (parts per million). An excess of salt is OK (maximum 5,000 ppm), **but TOO LITTLE SALT WILL CAUSE DAMAGE TO, AND SHORTEN THE LIFE OF YOUR 'CELL' – and void warranties on the 'Cell'.**

At startup of the ECO-Matic there must be at least 4,000ppm of salt (sodium chloride) in the pool water. The salt levels should not exceed 5,000ppm. This is simple to achieve if the following steps are taken:

- (i) Know, with reasonable accuracy, the pool/spa volume.
- (ii) Measure the pool water TDS (Total Dissolved Solids) prior to adding salt.
Note: the Conductivity Meter should be calibrated for sodium chloride. NOTE: Do not use Rock Salt or salt which contains YPS (Yellow Prussiate of Soda) or Iodine. Salt should be Fine or Medium Grade Solar Salt at 99.4% PURE NaCl
- (iii) Calculate the required start - up salt dose and add it to the pool. Adding 10 kg of salt per 10,000 litres will raise the salt concentration by 1,000 ppm (e.g. In a pool with no salt, a 100,000 litre pool will need 450 kg of salt to reach 4,500 ppm). If the pool is already operating as a salt pool, simply add enough salt to bring the level to 4,500 ppm
- (iv) Backwash the filters and add the salt by dumping it *along the* deep end of the pool. Pour the salt directly from each bag into the pool water. DO NOT load all the salt into one area, but rather move along the pool while pouring to distribute the salt evenly. During the time the salt is dissolving, do not backwash the filters. Heavier salted water will tend to flow into the deep end of the pool and could be backwashed out via the bottom drains. Brush salt to ensure mixing.

If the TDS is higher than expected then the pool volume may have been over estimated. This is not a cause for concern as more salt is far better than not enough! (Unless the salt level is above 7,000ppm - contact your supplier). It is possible to lower the salt concentration by partially draining the pool and refilling with fresh water.

Salt is effectively not consumed by the ECO-matic process - the salt is recycled

If you under-estimate the amount of salt required, your ECO-matic will indicate 'Low Salt'. Simply add more salt (first being sure that original salt is properly dissolved) until the ECO-matic indicates sufficient salt – Refer to your ECO-matic Installation and Operation Manual.

IMPORTANT NOTE: Newly plastered pools should run on traditional chlorine to “cure” the plaster for at least 2 to 4 weeks before adding the salt. Consult with the Pool Company for exact timing to ensure you do not void your warranty. Be sure to check for calcium buildup in the cell every 2 weeks. See page 23 for directions.

Installation Check List

Your ECO-matic installation is complete when the following have been completed:

- 'Cell Housing' installed into plumbing
- 'Cell' properly in place in 'Cell Housing'
- Power supply mounted in place and connected to the circulation pump main power (correct line voltage).
- 'Cell' connected to power supply
- Sufficient salt dissolved into pool water
- You have checked and confirmed that your ECO-matic power supply switches ON and OFF coincidentally with the filter pump.
- You have checked all connections and joints for leaks (including 'Cell' head O-ring).

Installation Trouble-Shooting

ECO-matic does not come ON when filter switched ON

1. Check ON/OFF switch on front panel of power supply
2. Power supply not properly connected to power supply (make sure correct voltage is getting to power supply)
3. Check fuses (front panel of power supply)

ECO-matic starts up with 2 red LEDs and varying display

1. Incorrect voltage to power supply. Check voltage.
2. Unit preparing to cut-out. Check salt level.

Understanding the ECO-matic System

Your ECO-matic uses the dissolved salt in the water to produce the sanitizer necessary to maintain your pool/spa water in a safe and healthy condition.

The amount of sanitizer produced by the ECO-matic and the quantity of salt (the salinity) in the water are related, but must be maintained and controlled as two separate factors:

Sanitizer:

The amount of sanitizer required for your pool varies from time to time and depends upon a number of variables, including the number of swimmers in the pool, water temperature, etc.

To determine whether your ECO-matic is producing sufficient sanitizer for YOUR pool/spa, the sanitizer level in the pool/spa must be measured using a Commercial Test Kit. The sanitizer level in the water can then be adjusted up or down as desired, by adjusting the quantity of sanitizer being produced by the ECO-matic (refer to **System Control**), if on manual control, or by adjusting the Chemistry Controller if on Automated Control.

Low sanitizer levels should not be confused with a low salt level, and adding more salt will not necessarily increase the sanitizer level. The salt level should be controlled and maintained separately – see below.

Salt Level (Salinity):

Your ECO-matic will indicate (Control Panel) whether the salt level in the water has fallen below the desired minimum operating level. The system will continue to produce sanitizer in low salt conditions (at a decreased rate, and only until the automatic Cut-Out applies) **Note: low salt conditions cause increased wear on the 'Cell' and will shorten the life of the 'Cell'**. When your ECO-matic indicates a Low Salt condition, add salt to the water to correct the situation. Measure and control sanitizer levels separately, as described above.

Note: Never add salt in order to increase sanitizer level. Only add salt, as necessary, to maintain minimum salt level.

The Amount of Sanitizer Produced by ECO-matic Depends Upon:

- a) The daily operating time of the equipment (pump/filter and ECO-matic).
- b) The **System Control** setting (high or low)
- c) The settings of the ORP Sensor
- d) The condition of the ECO-matic 'Cell' (clean or dirty)

The rate of sanitizer production will decrease as the 'Cell' accumulates scale (calcium, etc), or if the salt level in the water decreases and, in time, as the 'Cell' nears the end of its life.

Note: Your Test Kit is your ONLY INDICATOR of whether your ECO-matic is producing sufficient, too little, or too much sanitizer for your pool.

ORP Sensor

If your ECO-matic is producing TOO MUCH SANITIZER, reduce the ORP set point of your Chemistry Controller

If your ECO-matic is producing TOO LITTLE SANITIZER, increase the ORP set point, or check stabilizer/conditioner level and phosphate contamination. Also refer to your ORP (Chemistry Controller) owners manual.

Manual Control

If your ECO-matic is producing TOO MUCH SANITIZER, turn the system control down.

If your ECO-matic is producing TOO LITTLE SANITIZER, turn the system control up.

Controls and Display Panel

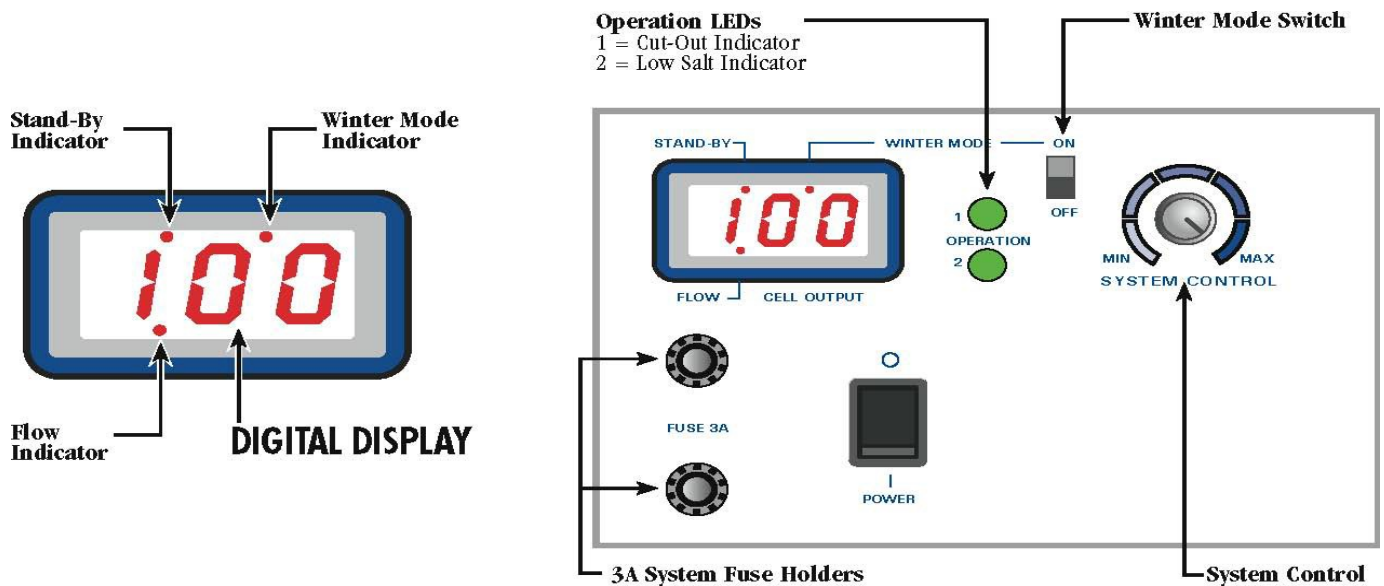

The rate at which your ECO-matic produces (sanitizer for your pool) varies (see below) and is indicated on the DIGITAL DISPLAY (Eg: 90 – 100 or in winter mode 75 – 85).

There are two lights on the Control Panel – LED 1 and LED 2 – which will indicate whether the system is working as intended or whether there may be faulty or damaging operating conditions (such as low salt levels). If these warnings are ignored, the Unit will either **Cut-Out** OR otherwise, continued operation will result in damage to the 'Cell'.

Start Up

1. Turn the POWER ON (first time only). Power setting "1". Switch filter pump ON (ECO-matic also gets power). ECO-matic power switch can then be left ON and filter power control will also control the ECO-matic.
2. The unit will enter a START-UP PHASE (which will repeat itself each time the system powers up). The STANDBY light will be ON, but there will be no 'Cell' output (sanitizer production).
3. After the Start-Up delay, the DISPLAY should indicate around 90 – 105 (unless set in the Winter Mode). With the correct amount of salt added and dissolved, both LED 1 and LED 2 will be GREEN. If LED 2 is RED, there is insufficient salt in the pool. See the table on the page 6 for other installation related problems.

Digital Display

The **DIGITAL DISPLAY** indicates how the ECO-matic is performing, compared to its maximum design output. 90(%) – 100(%) range is common. Normal Winter Mode readings 75 – 85.

Indicators - What They Mean

Output readings on the DIGITAL DISPLAY can fall due to any (or combination of) the following: cooler water temperatures, warming of power supply (in heated equipment rooms for example), lower than normal power voltage, lower salt levels, scaling occurring on 'Cell'.

Provided LED 1 and LED 2 are both GREEN (and the 'Cell' is not scaling excessively), your ECO-matic is performing (producing) satisfactorily.

Indicator	Display	LED1	LED2	What's Happening
STAND-BY ON	Blank	Green	Green	<ol style="list-style-type: none"> 1. Unit is in start-up mode 2. "Cell" is OFF cycle during normal operation (refer System Control) 3. System Control set at MIN.
FLOW ON	Blank	Green	Green	<ol style="list-style-type: none"> 1. Insufficient flow through "Cell" (Gas or air at Stand-By on "Cell", check pump/pipes for damage, leaks) 2. Gas Sensor lead not connected to "Cell" 3. System is wired incorrectly.
	Approx 90-100	Green	Green	System operating normally.
	Approx 90-100	Green	Red	<ol style="list-style-type: none"> 1. "Cell" is dirty, scale build up. Clean cell 2. Water Temperature Cold. Switch to Winter Mode 3. Salt level below min. Add salt 4. "Cell" failing. Test and/or replace "cell"
	Varying	Red	Red	Unit preparing to Cut-Out. (See low Salinity Indicator and cut out). <ol style="list-style-type: none"> 1. 'Cell" is dirty, scale build up. Clean cell 2. Water Temperature Cold. Switch to Winter Mode 3. Salt level below min. Add salt 4. "Cell" failing. Test and/or replace "cell"
STAND-BY ON	Blank	Red	Red	System protection activated. Unit has Cut-Out. Follow above procedures.
WINTER MODE ON	Approx 75-85	Green	Green	System operating normally - in Winter Mode. Only operate in Winter mode if water is very cold. Red LED(s): scaled "Cell" or low salt level.

Operation

- a) **Polarity Indicator:** The + or - symbol appears before the **Digital Output Display**, to indicate the polarity in which the system is operating (i.e. positive or negative direction of 'Cell' current). The symbol will alternate according to pre-set factory settings and does not effect the normal operation of the unit.
- b) **System Control:** When the **System Control** is being adjusted, the unit will indicate (flashing) the percentage of time that the 'Cell' will operate during the filtration cycle (for a few seconds, then display reverts to 'Cell' Output display).
- c) **'Cell' Cleaning:** The ECO-matic units use a patented Electronic Auto-Cleaning system for the 'Cell'. 'Cells' may eventually scale in extreme hard water conditions and will require manual cleaning if this occurs.
- d) The second **Low Salinity** warning phase (Red + Red LED's) is very short. Therefore on first warning phase (Red + Green LED's) prompt action is recommended to avoid **Cut-Out**.

Stand-by Indicator

The **Stand-By** indicator will be ON when the Unit is preparing to produce sanitizer. This will be either during the system's initial **Start-Up** or when the 'Cell' is in an OFF cycle during the filtration cycle (refer **System Control**). Stand-By indicator can also be ON after System Protection Cut-Out has activated. (i.e.: when unit has shut down).

Flow Indicator

If there is a problem with water flow or gas is detected in the 'Cell Housing' the **Flow** indicator will be ON. When this occurs the pump or pipes should be inspected for damage and the **Gas Sensor** on the 'Cell' checked for correct connection (and scale build-up on bolt head).

System Control (Output Control)

The **System Control** allows you to control the amount of sanitizer to be produced during any filtration cycle (filter operating time).

The setting on the **System Control** determines the amount of time for which the ECO-matic will operate during the filtration cycle. The **System Control** dial is graduated approximately as follows: 0% (MIN), 20%, 40%, 60%, 80%, (MAX) 100%.

The **System Control** will not vary the rate at which the 'Cell' will produce sanitizer (as indicated on the DISPLAY), just the 'time' for which the ECO-matic will produce sanitizer.

When the **System Control** is set to MIN, the 'Cell' will be OFF.

When the **System Control** is set to MAX, the 'Cell' will be ON.

The **System Control** is graduated in steps of 20% from MIN (OFF) to MAX (ON). (Refer diagram to the right)



If the 'Cell' is OFF and you wish to check its operation, simply turn the **System Control** to MAX and the 'Cell' will turn ON. Once checked, adjust the **System Control** back to the desired position and after a few minutes the 'Cell' will turn OFF again.

Backwashing the Filter: During this process, **System Control** must be set to Min (Off)

Note: If the ECO-matic is controlled by ORP chemical automation, turn the control knob to

Low Salinity Indicator and Cut-Out

Your ECO-matic is fitted with a number of protective features including the **Low Salinity Indicator**, and on some models, a **Cut-Out** feature.

As the salt level in the pool decreases, the wear on the 'Cell' increases. Although salt is not consumed in the ECO-matic process, it is lost through splashing, back-washing and on bathers as they leave the pool. The salt level is also reduced by rain, which causes dilution. Salt is not lost to evaporation.

As the salt level in the pool falls toward the minimum, **LED 2** will turn RED. At this point the salt level should be tested with a Saltline USA approved digital conductivity tester and salt added to reach a minimum of 4,000PPM. If no action is taken and the salt level continues to fall, the **Low Salinity Cut-Out** will activate and **LED 1** will also turn RED. It is advisable to test the salt level is in fact low, prior to adding salt, as LEDs 1 and 2 can activate for reasons other than 'low salt'.

When the Cut-Out feature activates, the ECO-matic will no longer produce sanitizer, but will switch itself ON a number of times each hour and assess whether the problem(s) (low salt for example) have been corrected. If the problem still exists, the unit will switch OFF once again.

Other factors which can activate the **Cut-Out** feature:

1. **Heavy Rain** - can cause very dilute pool water to pass over the 'Cell' due to surface skimming. The Unit will turn back ON after the rain has been mixed into the water unless the salt level has been reduced by dilution/overflow.
2. **Scaled 'Cell'** - a scaled 'Cell' will not draw as much electrical current as a clean 'Cell' when first started. This will cause the **Cut-Out** to operate. This is very beneficial as a scaled 'Cell' can cause an overload if it is operated for a few hours. Heavy scale build-up also increases the wear on the 'Cell'.
3. **Cold Water** - cold pool water reduces the ability of a 'Cell' to carry electrical current. (Refer **Winter Mode** below).
4. **Failing 'Cell'** - as 'Cell' ages there will come a time when the electrical current draw will drop. This can be compensated for with the addition of extra salt. A 'Cell' is considered failed when it draws less than 80% of maximum current. To keep a failed 'Cell' in operation, **Winter Mode** can be used along with extra salt. There will come a time when the 'Cell' will not respond to either extra salt or **Winter Mode**. It will then need to be replaced.

Winter Mode (Outdoor Pool/Spa Only)

When the 'Cell' draws electrical current from the Power Supply, the amount of current drawn is dependent upon a number of factors. Two of these factors are **Salinity** and **Water Temperature**.

The **Low Salinity Indicator** and/or **Cut-Out** on your ECO-matic are designed to operate at swimming season water temperatures. When the pool begins to cool in the off season the temperature drop causes the 'Cell' to behave differently – it will draw less electrical current. This can cause the **Low Salinity Indicator** and/or **Cut-Out** to assume that the salinity has fallen even if the salinity has remained relatively constant.

When the temperature of the pool water drops (typically when it is too cold to swim), the **Winter Mode** Switch should be placed in the ON position. The **Winter Mode** Indicator will then be ON.

Winter Mode setting has two effects:

1. It alters the setting of the **Low Salinity Indicator** and/or **Cut-Out**.
2. It reduces the Cell Output by approximately 15%.

The Unit will now respond to a cold pool environment. **Winter Mode** should not be used in the swimming season as it reduces the **Cell Output**, leading to less sanitizer, and it alters the setting of the **Low Salinity Indicator** and/or **Cut-Out**, which could lead to premature 'Cell' failure. It is recommended to turn off and stop using the ECO-matic at temperatures below 10°C (50F).

Gas Sensor

The smallest of the three leads which connect to the 'Cell' head is the **Gas Sensor**. Whenever the head of the Gas Sensor bolt loses contact with the water (due to gas or a air pocket in 'Cell', or scale build-up on sensor bolt head), your ECO-matic will **Cut-Out**.

Shocking the Pool

Periodically, if the pool is heavily used, to reduce combined chlorine (chloramines) or for a biological "accident" follow your local authority regulations and use Sodium Hypochlorite (Liquid Chlorine) as an additional source of chlorine.

Maintenance of your ECO-matic

The Power Supply

The power supply should require very little (if any) maintenance – except maybe for occasional replacement of blown fuses. However, damage to certain components may result from improper maintenance of the 'Cell' (see below). Always ensure that the power supply is located in a well ventilated area free of corrosive fumes from any acid or chemical containers in the vicinity.

Important Note: *The two most important maintenance requirements for your ECO-matic are:*

1. *Cleaning the 'Cell' and*
 2. *Maintaining sufficient salt level in the pool.*
-

The 'Cell'

Maintenance of the 'Cell' is quite simple, but very important. ECO-matic 'Cells' are comprised of expensive materials and even with proper care and maintenance the delicate coating on the 'Cell' anode will eventually wear away and the 'Cell' will 'die' and will no longer be able to produce sufficient sanitizer for the pool. Proper care (and cleaning) will ensure the maximum life for the 'Cell'. Operating your 'Cell' on lower-than-recommended salt levels will shorten 'Cell' life and void 'Cell' warranties.

Cell Life

The life expectancy of ECO-matic 'Cells' may vary considerably from one installation to the next, due to variations in daily operating time, water quality and composition, and system and 'Cell' maintenance.

Please ensure that when it is time to replace your 'Cell', you use only ECO-matic replacement 'Cells'.

The use of imitations (or copies) of the ECO-matic 'Cell' may harm the internal components of your ECO-matic power supply and will void warranties.

Cleaning the 'Cell'

Mineral salts, calcium, etc. (scale) will accumulate onto the 'Cell' and will effect the efficiency of the 'Cell' in its production of sanitizer. If allowed to build up unchecked, this scale can damage the 'Cell'. It is therefore essential that the 'Cell' be cleaned whenever necessary, as indicated by visual inspection, a drop in Output and/or RED LED(s).

The rate at which the scale accumulates on the 'Cell' varies from pool to pool and is influenced mostly by the Calcium Hardness, Total Alkalinity and the ratio of these two important components of water balance.

The manufacturer recommends that the water be balanced to LSI (Langlier Saturation Index) daily. Ensure that chlorine levels are between 1-3 ppm of free available chlorine for swimming pools and 3-5 ppm of free available chlorine for spas. This will result in less frequent cleanings and longer cell life. Rapid scaling on the 'Cell' indicates out of balance water.

Removing the 'Cell' For Cleaning

There should be no need to disconnect the 'Cell' from its leads for normal 'Cell' cleaning. However, it may be necessary at some time to disconnect the cell ('Cell' replacement, warranty or service reasons).

The 'Cell' leads connect to the 'Cell' Head with push-in bayonet type connectors. Simply twist and pull each connector to disconnect. The Gas Sensor lead is a push-on connection, simply pull to disconnect. Do not attempt to remove by pulling on the wires. Be sure to color-match the connectors when reconnecting.

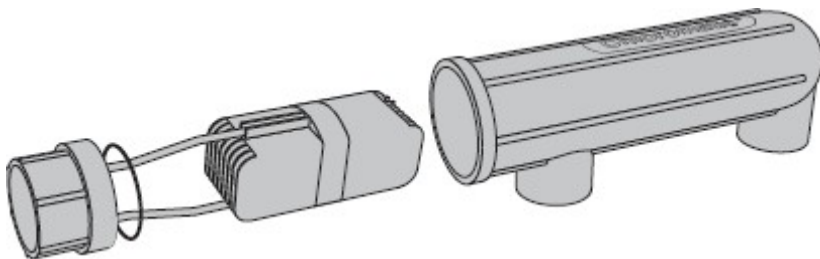

How to Clean the 'Cell'

- Turn OFF filter pump before attempting to clean the 'Cell'.
 - Remove the 'Cell' from the 'Cell Housing' by unscrewing the 'Cell' Head (Note: left-hand thread. Turn in direction of 'OPEN' arrow on 'Cell' Housing). No need to disconnect 'Cell' leads.
 - First, try to rinse off the cell with a hose if the scale is minimal. Do not use a pressure wash.
-
- Immerse the 'Cell' in to the weak acid solution (see below) for as short a time as necessary for the scale to be dissolved off the 'Cell'
 - If necessary, remove the 'Cell' from the weak acid solution, brush with a soft brush (never use a metal brush) to help remove stubborn scale, then re-immerse into the weak acid solution. Repeat until 'Cell' is completely clean of scale.
 - Remember to also clean scale off head of **Gas Sensor** bolt (on inside of 'Cell' head).

- Either rinse the acid solution off the 'Cell' using fresh water, or immediately replace the 'Cell' into the 'Cell Housing and start the filter (so the pool water rinses the 'Cell').

NEVER tap or knock the 'Cell' against hard objects to help remove scale. 'Cell' will break.

NEVER clean the 'Cell' in undiluted acid solution (always dilute in water – see below).

NEVER leave the 'Cell' immersed for long periods in the acid solution (remove and rinse as soon as scale is removed). Max 15-20 minutes.

When re-inserting the 'Cell' into the 'Cell Housing', ensure that the O-ring is in place (seated in the groove in the 'Cell' Head). If it is difficult to have the O-ring stay in its groove, apply lube gel to O-ring, then re-fit into groove. Do not over-tighten the 'Cell' (hand tight is OK).

Weak Acid Solution

Add 3 parts water to the 'Cell' cleaning container, then add 1 part acid (pool acid, muriatic acid) to the water, to a total depth which allows all of the 'Cell' to be immersed. Muriatic acid is corrosive. Please follow safety instructions and wear protective clothing.

Warning: NEVER add water-to-acid. ALWAYS add acid-to-water

The weak acid solution can be stored in a safe place and re-used for some time before becoming ineffective (saves having to make the solution each time). Avoid getting the weak acid solution on skin or in your eyes. If you accidentally do so, wash off immediately with fresh water (or use the pool/spa water).

Please do not hesitate to contact your ECO-matic Dealer for any assistance regarding 'Cell' cleaning.

Chemistry:

Salt

At startup of the Chlorinator System there must be at least 4,000ppm of salt (sodium chloride) in the pool water. The salt level should not exceed 5,000ppm. This is simple to achieve if the following steps are taken:

- (i) Know, with reasonable accuracy, the pool volume.
- (ii) Measure the pool water TDS (Total Dissolved Solids or Conductivity) prior to adding salt. Note: the Conductivity Meter should be calibrated for sodium chloride. NOTE: Do not use Rock Salt or salt which contains YPS or Iodine. Salt should be Fine or Medium Grade Solar Salt at 99.4% PURE NaCl
- (iii) Calculate the required start-up salt dose and add it to the pool. Adding 10 kg of salt per 10,000 litres will raise the salt concentration by 1,000 ppm (e.g. In a pool with no salt, a 100,000 litre pool will need 450 kg of salt to reach 4,500 ppm)
 - If the pool is already operating as a salt pool, simply add enough salt to bring the level to 4,500.
 - Note: Fill water can have existing salt level. Test with Conductivity Meter

- (iv) Backwash the filters and add the salt by dumping it along the deep end of the pool. DO NOT load all the salt into one area, as it will take longer to dissolve.

During the time the salt is dissolving, do not backwash the filters. Heavier salted water will tend to flow into the deep end of the pool and could be backwashed out via the bottom drains. Brush salt to ensure mixing.

If the TDS (Conductivity) is higher than expected then the pool volume may have been over estimated. This is not a cause for concern as more salt is far better than not enough! (Unless the salt level is above 7,000ppm - contact the factory). It is possible to lower the salt concentration by partially draining the pool and refilling with fresh water.

Salt is effectively not consumed by the ECO-matic process - the salt is recycled.

Note: Always use a Saltline approved Digital Conductivity Meter to measure salt content.

Pool Stabilizer (Cyanuric acid / Cyanurates)

(For Outdoor Pools Only- where allowed by local authority regulations)

- (i) Measure the stabilizer level using an appropriate test kit. It should be between 15 and 25ppm.
- (ii) If the pool has never had stabilizer added, then approx. 25ppm of stabilizer should be added. Follow the directions for adding it or load it directly into the pool pump inlets.

IMPORTANT: Stabilizer is very slow to dissolve and if it is loaded into the pump inlets it can sit in the filters for a number of days. If the filters are backwashed it will be lost. Monitor the stabilizer prior to back washing.

- (iii) If there is some stabilizer present, but it is below 25ppm, add enough to make up the 25ppm.

IMPORTANT: stabilizer is for use in outdoor pools only. It is used to reduce the loss of chlorine due to the effect of sunlight. It should not be used in indoor pools as it may adversely affect pool chlorine demand.

Other Chemical Levels

The other chemical levels to be aware of are pH, Total Alkalinity and Calcium Hardness.

The manufacturer highly recommends that you test and balance your water to L.S. I. (Langlie r Saturation Index) daily.

Simply follow basic pool guidelines, bearing in mind the following:

	Swimming pool	Spa
--	----------------------	------------

Free available chlorine	1.0 - 3.0 ppm	3.0 - 5.0 ppm
pH	7.2 - 7.8	7.2 - 7.8
Total alkalinity	100 - 120 ppm	100 - 120 ppm
Calcium hardness	200 - 300 ppm	150 - 200 ppm

- (i) Very high Calcium Hardness with Magnesium present in the water may present a problem to the Self-Cleaning properties of the system and therefore require additional cell inspections and cleanings.
- (ii) Phosphates: should be less than 200 ppb (Parts per billion)
Phosphates are food for algae and will increase chlorine consumption thus shortening cell life if present in water. Remove phosphates with Saltline approved Phosphate Remover.

Possible Chemical Problems

- (i) The use of sulphate containing chemicals may promote the production of oxygen compounds at the cell, which can lead to slightly lower chlorine production, and the production of chemicals which can adversely affect ORP probes. Chemicals to avoid
 - Sulphuric acid
 - Sulphate flocking compounds
 Note: the use of potassium monopersulphate is acceptable.
- (ii) The use of quaternary ammonium compounds (Quats) as an algaecide can promote turbidity (cloudiness). This is caused by the very high chlorine levels in the cell reacting with the Quats compound. A common Quats compound is benzalkonium chloride (also known as alkyldimethylbenzylammonium chloride or ABDAC)
- (iii) The use of Citric Acid as a "black spot remover" will cause the chlorine residual reading in the pool to fall to zero for an extended period of time.
- (iv) Hydrogen peroxide, peroxygen chemicals and peroxide in general do not interfere with the ECO-matic System but can seriously affect the ORP probes (redox probes) on chlorine/redox/ORP controllers.

Trouble Shooting

ECO-matic Not Working

1. No power getting to Power Supply.
2. ECO-matic switched OFF.
3. **System Control** set to MIN.
4. Blown fuse(s).
5. **Gas Sensor** Lead not connected securely. Scale build-up on **Gas Sensor** bolt head.
6. ECO-matic has **Cut-out** – insufficient Salt in the water, or 'Cell' needs cleaning, or water temperature cold.
7. 'Cell' needs replacing.

Rapid Salt Loss

1. Check for leaks in pool. Turn off any automatic fill device, check for water loss.
2. Heavy rain can dilute salt level.

ECO-matic Producing, But Sanitizer Level Low

1. 'Cell' dirty.
2. **System Control** set too low.
3. Insufficient operating time.
4. Low Salt level.
5. Conditioner level too low.
6. Filter or pump strainer needs cleaning.
7. Poor flow rate may be creating air pocket in 'Cell'.
8. Check for nitrates and phosphates.
9. Winter Mode on during swimming season.

ECO-matic Scaling Too Frequently

1. Total Alkalinity (and pH) too high.
2. Calcium Hardness too high. - Balance to LSI

Water Leaking At 'Cell' Head

1. Loose O-ring or O-ring out of its groove.

Warranty Details – One Year Full Warranty

The manufacturer warrants to the original purchaser of the ECO-matic MEMS16USA Automatic Chlorine Generator system that if any component, other than fuses, proves to be defective within a period of 12 months from the date of customer purchase, the manufacturer will provide full replacement of the part (including labor charges if required). Warranty does not include onsite labor or shipping.

During the Warranty Period, any defective product shall be returned to the distributor by the AUTHORIZED DEALER, accompanied by proof of date of purchase. No product shall be returned before calling for an RMA # to attach to return. The manufacturer will, at its option, either replace or repair the defective product and return it. Customer pays for all shipping. The manufacturer accepts no responsibility other than the repair or replacement of defective product and this Warranty specifically excludes product failure due to accidental damage, abuse, misuse, negligence, damage due to non-compliance with Installation or Operating/Maintenance instructions or unauthorized alterations or modifications to the product

Davey Water Products Pty. Ltd
6 Lakeview Drive
Scoresby, Victoria 3179
Australia 61 397 309 232

Your Local ECO-matic Dealer

**ACTUAL SIZE TEMPLATE
SCREW POSITION TEMPLATE
2 5/8"**

Use this template for mounting power supply
See page 10 for details.

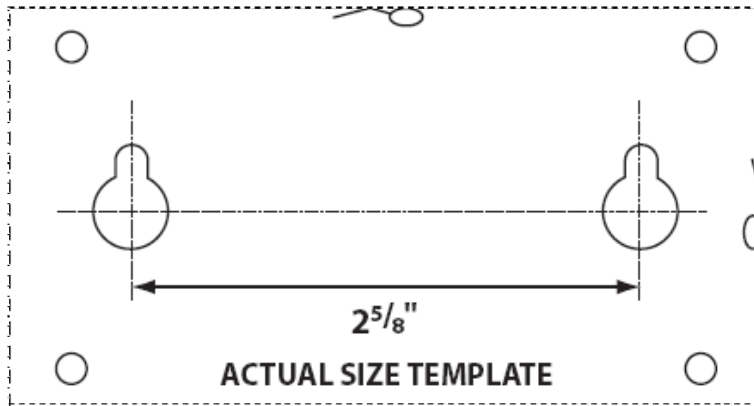

Screw Position Template

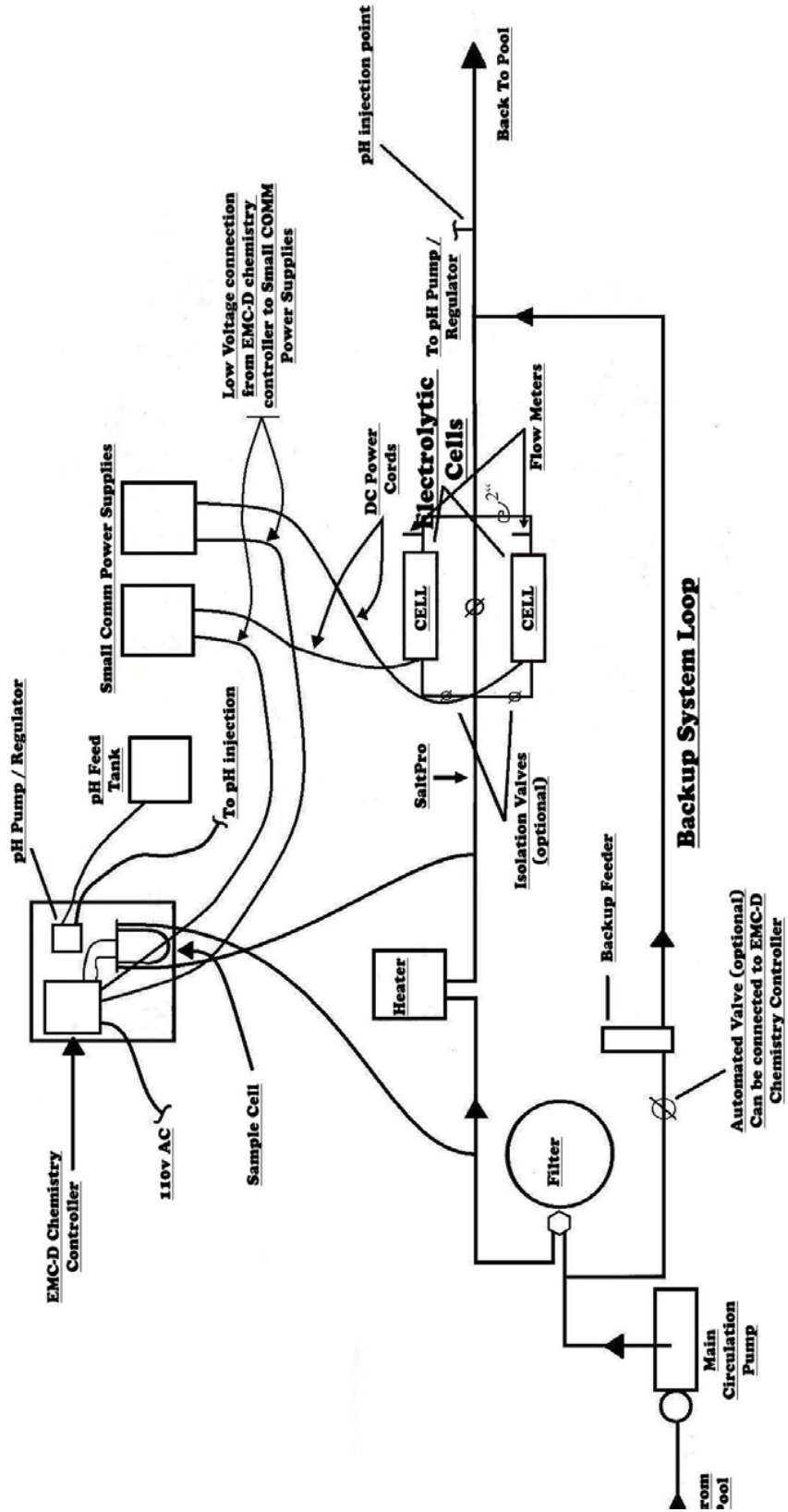

**Small COMM
Flow Rates**

COMM160	COMM360
25GPM	25GPM
↓	↓
50GPM Max	50GPM Max

NOT TO SCALE