

2014-3223

2014-12-23

CELL LABEL

**RETRO CELL**

**SALTRON RETRO (MODEL NO.: CLG10A) REPLACEMENT CELL**

**DOMESTIC**

Replacement electrode for the chlorine generating device SALTRON RETRO

(MODEL NO.: CLG10A)

REGISTRATION NUMBER 31672, PEST CONTROL PRODUCTS ACT. This cell must only be used on this model of chlorine generating device.

READ THE LABEL AND THE INSTALLATION AND OPERATION MANUAL OF THE CHLORINE GENERATING DEVICE SALTRON RETRO (MODEL NO.: CLG10A) BEFORE USING.

Solaxx, 601 N. Congress Ave., Suite 308 Delray Beach, Florida, U.S.A, 33445

Tel: 561-455-0252

DEVICE LABEL

**SALTRON RETRO (MODEL NO.: CLG10A)  
CHLORINE GENERATOR**

CONTROLS BACTERIA AND ALGAE  
In Pool Water  
DOMESTIC

A maximum of 75708 L (20,000 Gallons) of water can be treated with one SALTRON RETRO unit.  
Maximum output of hypochlorous acid equivalent to 0.192 kg of free available chlorine per day  
For pools, a range of 1-3 ppm of free available chlorine must be maintained.

READ THE LABEL AND OPERATING MANUAL BEFORE USING  
KEEP OUT OF REACH OF CHILDREN  
REGISTRATION NO. **31672** PEST CONTROL PRODUCT ACT

**WARNING: operating SALTRON RETRO without water flow through the cell can cause a build up of flammable gases which can result in FIRE  
OR EXPLOSION.**

Solaxx, 601 N. Congress Ave., Suite 308 Delray Beach, Florida, U.S.A, 33445  
Tel: 561-455-0252

Manual



# Portable Salt Chlorine Generating System

Installation and  
operating instructions

# Portable Salt Chlorine Generating System

INSTALLATION AND OPERATION MANUAL  
DOMESTIC

READ LABEL AND THIS MANUAL BEFORE USING

REG. NO. 31672 P.C.P. Act

**WARNING: To reduce the risk of injury, do not permit children to operate the device**

**WARNING: Heavy pool usage, and higher temperatures may require higher chlorine output to maintain proper free available chlorine residuals.**

If additional chlorine is required due to heavy bather loads , use liquid chlorine to maintain an appropriate chlorine residual in the water

**DO NOT add pool chemicals directly to the skimmer. This may damage the cell.**

Maintaining high salt and chlorine levels above recommended range can contribute to corrosion of pool equipment.

Check the expiry date of the test kit as test results may be inaccurate if used after that date.

Follow all aspects of the local and Canadian Electrical Code(s) when installing this device.

The life expectancy of the electrode is 7,500 hours under normal use conditions.

When replacing the electrode, only use replacement electrodes having a label that clearly states that it is a replacement electrode for the **Saltron® RETRO** Portable Salt Chlorine Generator (MODEL NO.: CLG10A), **REGISTRATION NUMBER 31672**, PEST CONTROL PRODUCTS ACT.

Follow all aspects of the local and National Electrical codes when installing **Saltron® RETRO** (Model No.CLG10A)

## INTRODUCTION

Saltron® RETRO Sanitation System produces a pure form of chlorine by electrolysis of salt (NaCl) in order to sanitize your pool water. After the salt is converted to chlorine and the bacteria are killed, the chlorine converts back to salt and this process is ongoing. The salt concentration used is very low (less than that in a human tear). Chlorine output can be easily adjusted by the timer on the power supply unit. The chlorine level in your pool can be checked by using a standard chlorine test kit. One Saltron® RETRO unit can treat up to 75,708L (20,00 gallons) of water).

## IMPORTANT SAFETY INSTRUCTIONS.

### READ AND FOLLOW ALL INSTRUCTIONS

**WARNING:** Risk of Electric Shock. Connect only to a grounding type receptacle protected by a groundfault-circuit-interrupter (GFCI). Contact a qualified electrician if you cannot verify that the receptacle is protected by a GFCI.

**WARNING:** Make sure the power supply is unplugged from the wall outlet when using pol.

**WARNING:** To reduce the risk of injury or electric shock, do not allow children to use this product.

**WARNING:** Power supply should be installed in a shaded area to protect the transformer from direct sunlight.

**WARNING:** Disconnect the power supply from the outlet when not in use.

**WARNING:** Do not operate with a damaged cord or power supply.

**WARNING:** To avoid risk of electrical shock, do not put the power supply in the water.

**WARNING:** To reduce the risk of electric shock, do not use extension cords to connect unit to electric supply; if necessary, contact a qualified electrician to provide a properly located outlet.

**WARNING:** Make sure the power supply is unplugged from the wall outlet when cleaning/servicing the cell assembly.

This appliance is not intended for use by persons (including children) with reduced physical, sensory or mental capabilities, or lack of experience and knowledge, unless they have been given supervision or instruction concerning use of the appliance by a person responsible for their safety.

Children should be supervised to ensure that they do not play with the appliance.

If the supply cord is damaged, it must be replaced by the manufacturer, its service agent or similarly qualified persons in order to avoid a hazard.

### SAVE THESE INSTRUCTIONS

## SPECIFICATIONS:

Saltron® RETRO Power Supply:  
Size: For pools up to 75,708L  
(20,000 gallons)

### INPUT:

120VAC, 50/60HZ, 3.0AMP  
230VAC, 50/60HZ, 1.5AMP

### OUTPUT:

20 VDC, 4.0 Amp (40°C / 104°F)

### Saltron® RETRO Cell:

Normal output equivalent to 0.192  
kg (0.07 lbs) of free available  
chlorine per day.

### Reverse Polarity Function:

The Reverse Polarity Function is designed to automatically clean the cell plates, maximizing the cell's ability to manufacture chlorine.

Chlorinator



Power Supply  
(transformer)

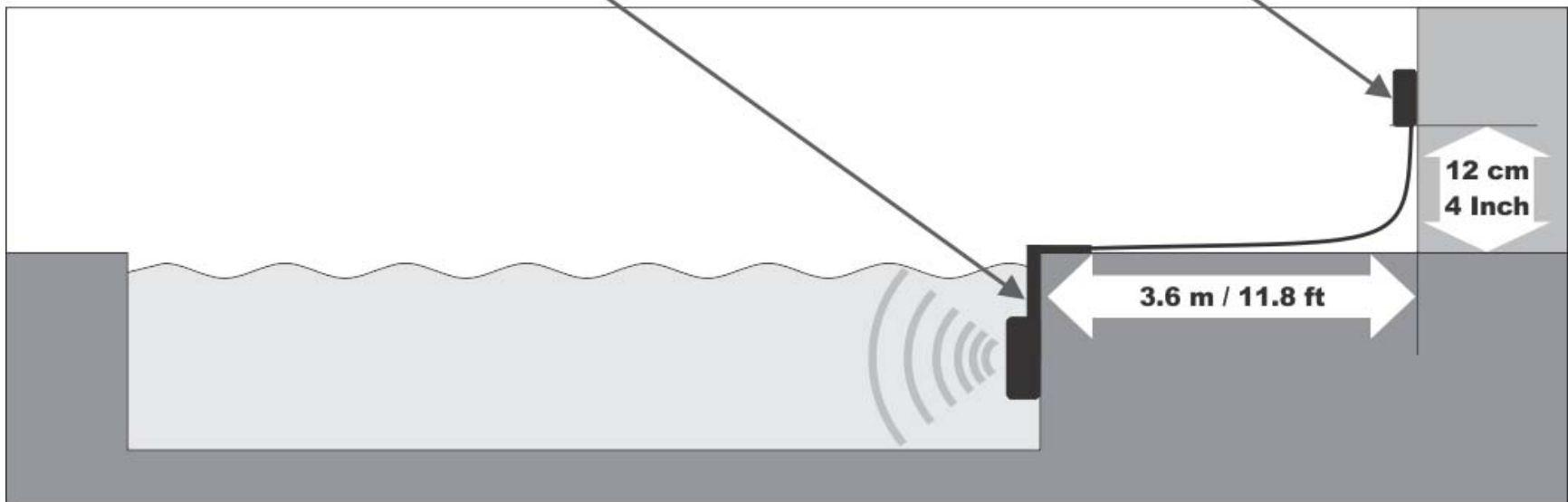

### Important

Place the power supply (transformer) at least 3.6 meters / 11.8 feet from the pool and at least 12 cm / 4 Inch above the surface. The transformer will supply low voltage to the chlorinator.

## INSTALLATION

1. The pool chemistry must be balanced before installing the system in the swimming pool. (see pg. 7)

2. Locate an area of the pool which has an easy access to a GFCI outlet. This product will work best if installed in close proximity to the pool return, which is an outlet where water is returned to the pool after going through the filter system.

3. For above-ground pool installation, remove screws and caps securing the top ledge of the pool in the desired area (Fig.1) Hang the plastic body on to the wall and tighten the bracket screw to secure against the wall. Re-attach the cap to the pool ledge. (Fig.2)

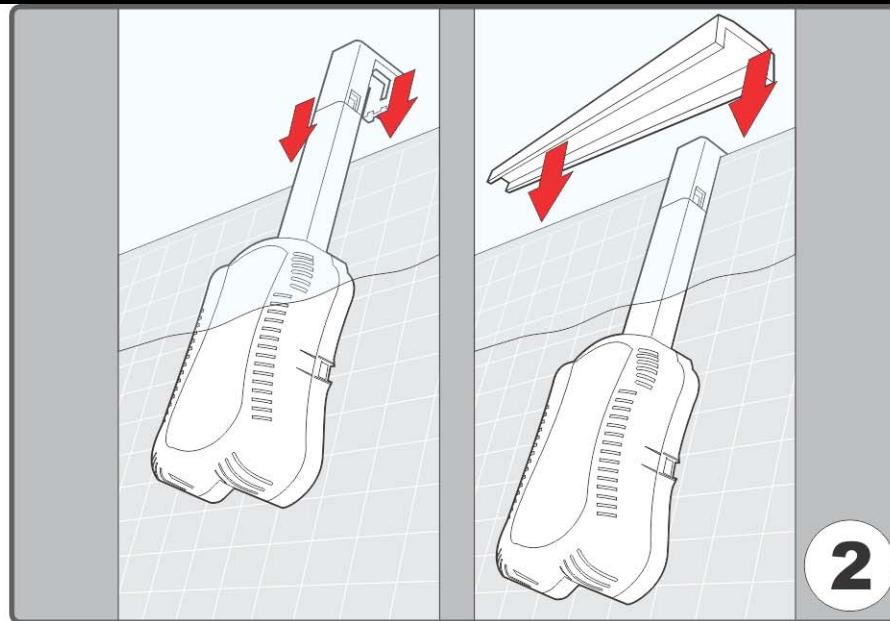
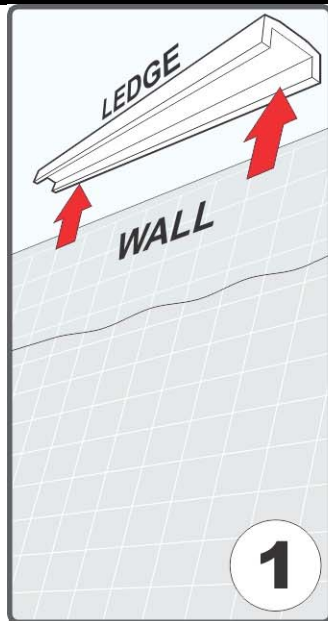

4. For above-ground pool installation, the upper hanger (above-ground) should be affixed to the lower hanger using the following steps:

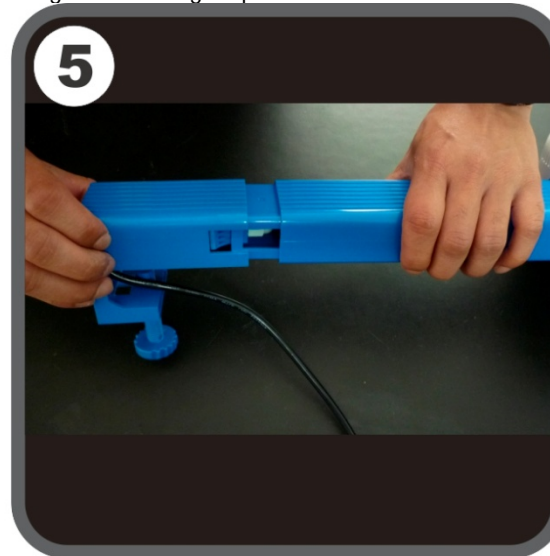
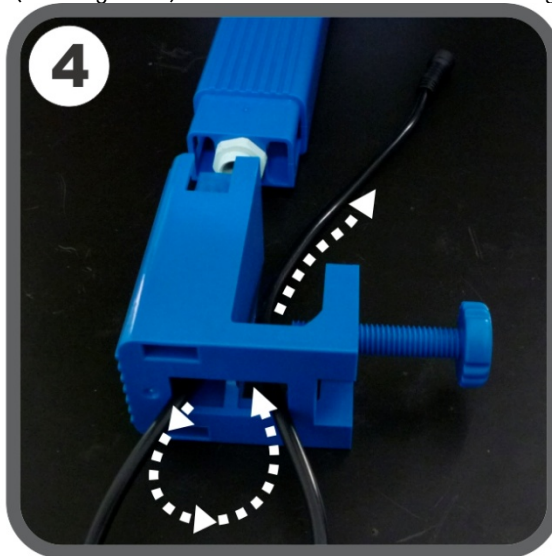
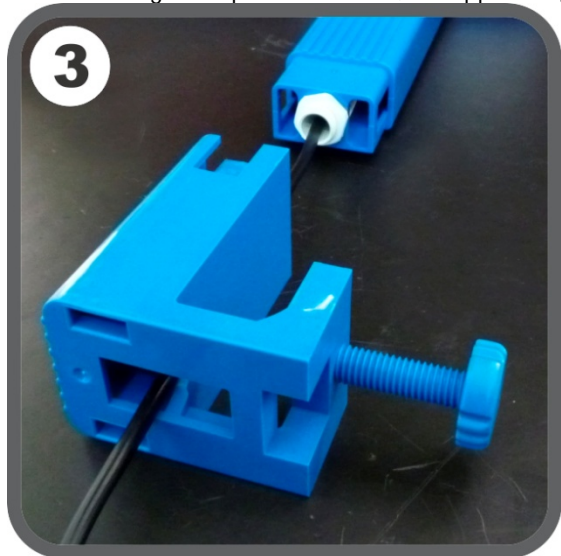



a. Pull cable up through upper hanger (Fig.3).

b. Push cable back through other hole of upper hanger (Fig.4).

c. Secure upper hanger AG to lower hanger (Fig.5).

## INSTALLATION

For In-ground pool installation, the upper hanger (In-ground) should be affixed to the lower hanger using the following steps:

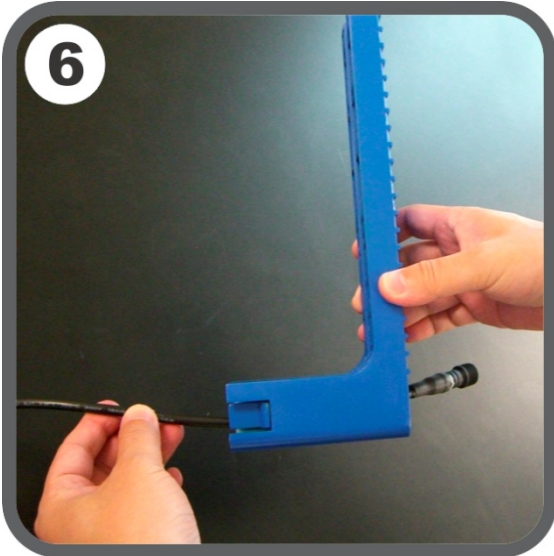

a. Pull the cable up through the middle hole of the upper hanger IG (Fig.6).

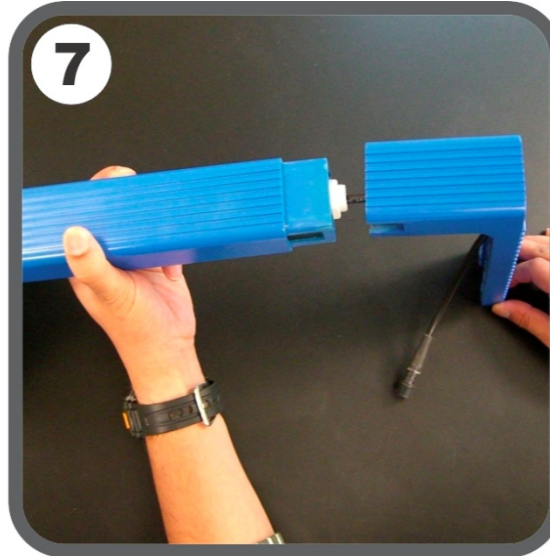

b. Snap the upper hanger IG onto the lower hanger (Fig.7).

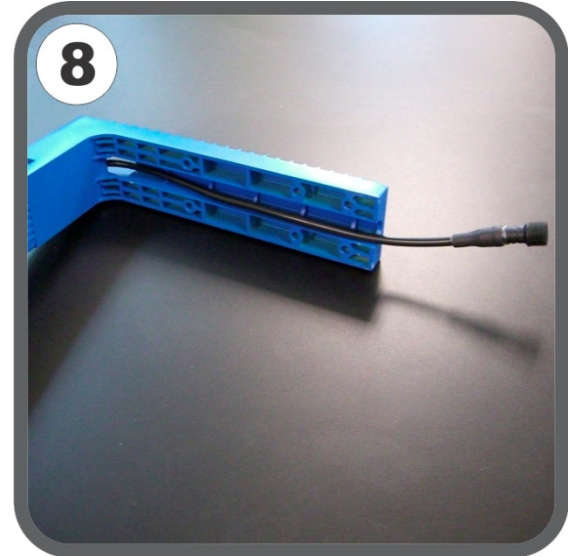

c. Loop the cable through the upper hanger hole and under the assembly (Fig.8).



5. Affix the upper hanger directly on the pool edge using hardware kit provided (Fig.9).
6. Adjust the thumb screws so that both are touching the pool wall (Fig.10, 11).

## INSTALLATION



7. Affix the power supply to a wall or a post near the pool in a shaded area (Fig.12).
8. Connect the cell cable connector securely into the power supply cable connector (Fig.13).
9. Plug power supply into the GFCI outlet.
10. Bubbles will rise from the unit in the water and a white milky cloud may be observed. This is absolutely normal and no special attention is needed.
11. The unit will default to 20 hours of chlorination per day and the green LED should be illuminated. If the HIGH or LOW SALT LED is illuminated, please refer to the troubleshooting section of this manual.
12. Leave the unit on its default setting for a few days and monitor the chlorine level each day. To adjust the chlorine setting on the power supply, refer to the Chlorine Adjustment section of this manual.

Failure to mount the power supply vertically will void warranty

This system is designed to automatically generate the chlorine for your pool. It is very important to note that chlorine is just one component of your pool chemistry. Please make sure your pool meets the optimum chemistry levels in the following Pool Chemistry Chart. Test your water weekly or take a water sample to your nearest pool store. Maintaining these levels will maximize the life of this product. Be sure to inform the pool professional that you are using a chlorine generator.

## Pool Chemistry Chart

FACTORS EFFECTING POOL CHEMISTRY	MAINTAIN LEVELS DAILY
1. Salt	3000 to 4000 ppm
2. PH	7.2 to 7.8
3. Free Chlorine	1 to 3 ppm
4. Total Alkalinity	100 to 120 ppm based on the Saturation Index
5. Cyanuric Acid	30 - 100 ppm
6. Saturation Index	0 ± 0.3
7. Phosphates	0 ppm
8. Nitrates	0 ppm
9. Metals	0 ppm
10. Calcium Hardness	200-3000ppm

## CHLORINE ADJUSTMENT

After everything is setup, the display will show you a default screen with the current hours of operation per day. You may change this setting anytime by holding "▲" down for 3 seconds straight. The display will flash indicating it is now ready for time setting changes. In order to determine the proper chlorine timer setting for your pool, measure the free chlorine level daily and adjust the timer accordingly to achieve 1-3 ppm of free available chlorine. It is advised to check the chlorine level daily to make sure the pool is properly sanitized. Weather, bather load, and sunlight have a major influence on the chlorine demand of the pool.

Note: If the pool has reached an undesirable amount of chlorine, it is recommended to unplug the power supply from the GFCI outlet. Check chlorine levels each day until the desired level is achieved. Plug the power supply back into the GFCI outlet once the chlorine level is within the desired limit.

## SALT REQUIREMENT

The best salt is a food-quality granulated salt, a 99.9% pure salt or solar salt. These types of salt should be purchased from a pool store and are designed for use with chlorine generators.

Do not use rock salt, iodized salt or salt with anti-caking additives. Do not use salt with more than 1% yellow prussiate of soda.

**Salt Table: Amount of salt needed to achieve 3000 ppm level in your pool.**

Pool Size in Cubic Meters (Gallons)	Salinity (ppm) measured in pool							
	0	500	1000	1500	2000	2500	3000	3500
38m3 (10,000)	114 kg/ (250 lbs)	95 kg/ (210 lbs)	76 kg/ (170 lbs)	57 kg/ (125 lbs)	38 kg/ (85 lbs)	19 kg/ (40 lbs)	0	0
45m3 (12,000)	136 kg/ (300 lbs)	114 kg/ (250 lbs)	91 kg/ (200 lbs)	68 kg/ (150 lbs)	45 kg/ (100 lbs)	23 kg/ (50 lbs)	0	0
53m3(14,000)	159 kg/ (350 lbs)	132 kg/ (290 lbs)	106 kg/ (235 lbs)	79 kg/ (175 lbs)	53 kg/ (120 lbs)	26 kg/ (60 lbs)	0	0
61m3(16,000)	182 kg/ (400 lbs)	151 kg/ (335 lbs)	121 kg/ (270 lbs)	91 kg/ (200 lbs)	61 kg/ (135 lbs)	30 kg/ (70 lbs)	0	0
68m3(18,000)	204 kg/ (450 lbs)	170 kg/ (375 lbs)	136 kg/ (300 lbs)	102 kg/ (225 lbs)	68 kg/ (150 lbs)	34 kg/ (75 lbs)	0	0
76m3(20,000)	227 kg/ (500 lbs)	189 kg/ (420 lbs)	151 kg/ (335 lbs)	114 kg/ (250 lbs)	76 kg/ (170 lbs)	38 kg/ (85 lbs)	0	0

The optimum salt level is between 3000-4000 ppm. Use the chart above to determine the amount of salt for your pool. The column on the left is the amount of water in your pool. The column on the top is the current salt level measured in your pool. Always check your salt level before adding salt to the pool even if this is your first time.

Prior use of liquid chlorine and tablets could have caused an increase in salt levels.

## CHLORINE ADJUSTMENT

### Adding Salt:

Turn on the pool pump system and add salt directly to the pool. Use a brush to help dissolve the salt quickly. Any pool cleaner can be used to help dissolve the salt as well. Run the pool pump system for 24 hours to make sure salt is properly dissolved. Do not add salt to the skimmer because this could damage the main pool equipment.

### Removing salt from the pool:

Salt should not be removed from the pool unless the salinity exceeds 4500 ppm or the salinity of the water is undesirable. The only way to remove salt is by draining the pool and adding fresh water.

## POOL SIZE CALCULATION:

Use the following table based on the proper unit of measurement to determine your pool size.

Pool Shape	Volume in Liters (Units in meter)	Pool Shape	Volume in Gallons (Units in ft)
Rectangular	Length x Width x Average Depth x 1000 = Liters	Rectangular	Length x Width x Average Depth x 7.5 = Gallons
Circular/Round	Diameter x Diameter x Average Depth x 785 = Liters	Circular/Round	Diameter x Diameter x Average Depth x 5.9 = Gallons
Oval/Elliptical	Length x Width x Average Depth x 893 = Liters	Oval/Elliptical	Length x Width x Average Depth x 6.7 = Gallons

### Stabilizer (Cyanuric Acid) Levels:

Cyanuric acid is a critical component to the proper function of the system. It is very important to check cyanuric acid levels on a regular basis. Cyanuric acid helps prevent the chlorine from being destroyed by the sun rays. Thus, the system will have a longer lifetime. The optimum stabilizer level is 80 ppm.

Stabilizer/conditioner is found in liquid or granular form. When adding granular stabilizer to the pool, make sure you give it time to dissolve. Check levels for several days after adding and before adding more.

## UNIT MAINTENANCE

### Inspecting the Cell:

The cell should be inspected every 3 months. Unplug the system from the GFCI socket. Remove the cover of the cell housing so that the cell is exposed. Push the tab with your finger and remove the cell. Inspect the cell for scaling (white, sugar-like) deposit. If scaling exists, the cell should be cleaned.

### Cleaning the cell:

To clean the cell, a bucket or a large cup should be used. The bucket should be filled with 80% water and 20% muriatic acid. NEVER ADD WATER TO ACID, only acid to water. It is recommended to wear safety goggles when handling the acid. Place the entire cell into the bucket for 20 minutes. Remove the cell and dump the water from the bucket into the pool. If the scaling remains, repeat the process. NEVER USE ANY TOOLS TO CLEAN THE SCALE DEPOSIT. This will damage the plates and result in immediate loss of warranty. After the scale is removed, rinse the cell with fresh water. To re-install, replace cell into housing. Replace cover onto base. Replace cell housing onto the hanger on the pool edge using the snapping mechanism.

**Note:** It is acceptable to use household vinegar to soak the cell if acid is not available or not preferred.

**Winterizing:** Remove the cell housing from the pool. It is only necessary to remove it if the temperatures during the winter drop below 32 F (0 C) where you live. Clean the cell before storing the system indoors. If the housing is not removed from the pool for winterization, freezing water will cause damage to the cell resulting in loss of warranty.

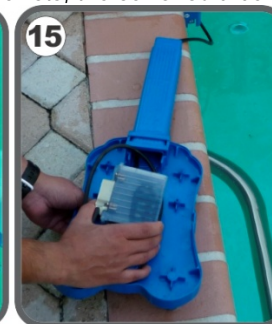

## OPERATION MODE AND TROUBLE SHOOTING

Symptom in power Supply		Possible causes		Solution	
	Display	LED			
1	no display	no lights	1 - power outage 2 - fuse burnt 3 - power supply failure	Make sure there is power to the unit. Check and change the fuse if it's burnt. Call customer service	
2	"- -"	no lights	System is in rest mode	No action is needed. If you want it to operate immediately, unplug/plug the power or adjust the timer. Both will start the operation right away.	
3	"- -" and Hours (20 by default) alternating	no lights	1 - chlorinator cell is outside the water 2 - open circuit in chlorinator cell	Put it back into the water or fill water line halfway up the plastic body.  Check the wire connections and make sure no cut or broken wire.	
4	"LO" and Hours (20 by default) alternating	Yellow light	1 - salt level low 2 - water temperature low 3 - chlorinator cell at its life end	Add more salt to the pool and allow time to dissolve. Don't use the system if the water temperature is under 65 °F (or 15 °C). Call customer service for replacement.	
5	Hours (20 by default)	Green light	normal operation mode	No action is needed.	
6	"HI" and Hours (20 by default) alternating	Red light	1 - salt level high 2 - water temperature high	No action is needed. Stop adding salt to water if you are doing so. Using this system in water temperatures above 100 °F (or 45 °C) such as pool water is not recommended.	
7	"HI"	Red light blinking	1 - salt level too high  2 - water temperature too high 3 - short circuit in chlorinator cell	You will have to dilute your pool water with fresh water until you reach 3000 ppm salt level. Stop using the system until water cools down.  Check to make sure there is no metal objects caught in between the electrode plates.	
8	"88" blinking	All lights blinking	Power supply outage	Unplug and plug in the power cord to reset the power supply. If the problem persists, call customer service.	
<b>Symptom in Pool Water</b>					
9	chlorine level is low		Hours set too low	Adjust the hours setting to higher number (the maximum is 24 hours/day). Make sure the cyanuric acid level in your pool is between 50-80 ppm	
10	chlorine level is too high		Hours set too high	Adjust the hours setting to lower number (the minimum is 0 hours/day).	

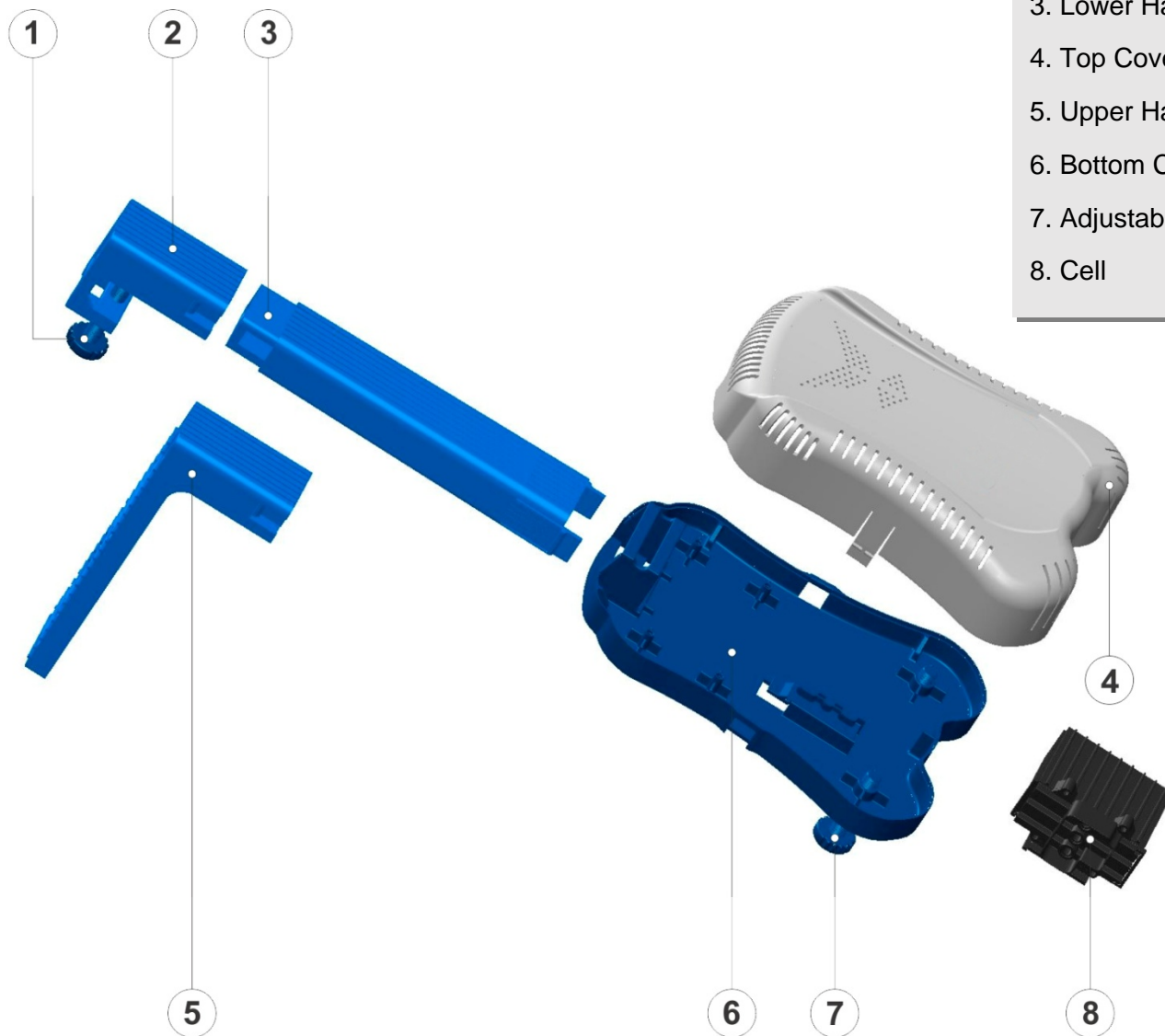

### PARTS LIST

1. Thumb Screw for Above-Ground Pool
2. Upper Hanger for Above-Ground Pool
3. Lower Hanger
4. Top Cover
5. Upper Hanger for In-Ground Pool
6. Bottom Cover
7. Adjustable Thumb Screw
8. Cell