

Vision

Water Purifier for Pools

Reduces stinging eyes, dry skin or bleached fabrics.

Satisfaction guaranteed or your money back.

Saves Time and Improves Water

Helps maintain your pool... with low chlorine levels*

Contains Nature2 Mineral Purifiers for Pools

*Minimum level: 0.6 ppm free chlorine

The Nature2 Water Purifier

It feels better.

- Reduced chlorine & chemical use.
- Lessens stinging eyes, dry skin & damaged hair.
- Lowers harsh chemical odors.
- Reduces bleached & damaged bathing suits.

Nature2 water is brilliantly clear and soft.
Conventionally sanitized pools.

It's safe.

- Stable, safe swimming water.
- Compatible with other pool maintenance products.

Absolutely safe for kids!

It works better.

- Patented mineral process controls bacteria.
- Saves time & money.
- No electricity, no moving parts. It's powered by water flow.
- Reduces work & chemical volume.

Model NA

Vinyl Lined Pools

Capacity: Up to 114,000 litres (up to 30,000 U.S. gallons)

Warranty: 5 years (housing)

Cartridge Selection: CNA 30ec 18,000-114,000 litres (5,000-30,000 U.S. gallons)

Cartridge Life: Seasonal cartridge

* A minimum of 0,6 ppm free available chlorine must be maintained.

Model NG

For Concrete Pools

Capacity: Up to 133,000 litres (35,000 U.S. gallons)

Cartridge Selection: CNG35

Nature2 is a trademark of Zodiac Pool Care, Inc.

© 1998 Zodiac Pool Care, Inc. (D) Zodiac Pool Care, Inc.

L40227

Text label (English) for:

Cartridge For Vision Purifier For Vinyl Lined Pools Model NA (Vision CNA 30ec)

Purifier Cartridge For Vinyl Lined Pools

Nature-2 logo/ Purification Technology

DOMESTIC

- To be used with purifier for vinyl lined pools: NA
- READ LABEL AND REFER TO OWNER'S MANUAL BEFORE USING
- Maximum operating pressure 173 kPa

To assist in controlling bacteria and algae growth, this device will augment bactericidal and algicidal activity of primary disinfectants such as chlorine in swimming pools and spas.

A minimum of 0.6 ppm of available chlorine must be maintained. In case of regulated pools, Provincial/Municipal regulations must be followed.

Covered by one or more of the following U.S. Patents:

4,608,247 4,935,116 5,352,369

REG NO. 24575 P.C.P.ACT

WARNING

Staining of pool surfaces may occur due to deposits of copper salts. Excessive levels of copper will increase the probability of this occurrence.

Zodiac Pool Systems Inc.
2620 COMMERCE WAY
VISTA CA 92081
UNITED STATES
1-800-822-7933

VISION PURIFIER FOR VINYL LINED POOLS

MODEL NA

DOMESTIC

Uses replacement cartridge: CNA 30ec

READ LABEL AND REFER TO OWNER'S MANUAL BEFORE USING

Maximum Operating Pressure 173 kPa

To assist in controlling bacteria and algae growth, this device will augment bactericidal and algicidal activity of primary disinfectants such as chlorine in swimming pools and spas.

A minimum of 0.6ppm of available chlorine must be maintained. In the case of regulated pools, Provincial/Municipal regulations must be followed.

Covered by one or more of the following U.S Patents:

4,608,247 4,935,116 5,352,369

REG. NO. 24575 P.C.P.ACT

WARNING

Staining of pool surfaces may occur due to deposits of copper salts. Excessive levels of copper will increase the probability of this occurrence.

Zodiac Pool Systems, Inc.

2620 COMMERCE WAY □ □ VISTA CA 92081 □ □ UNITED STATES 1-800-822-7933



ZODIAC

Purifier for Vinyl Lined Pools

Operating Manual



READ THE LABEL AND OPERATOR'S MANUAL BEFORE USING

KEEP OUT OF REACH OF CHILDREN

Pool owner, save this manual!

Builders, leave this manual with the pool owner!

Specifications

Capacity: 18,000 L to 114,000 L

Dimensions: 405 x 241 x 292 mm

Ports: 38 mm (1.5 inch) FPT threaded connections, inlet and outlet

Weight: 2.6 kg

Circulation system flow rate: 95-303 L/min

Purifier flow rate: 38-68 L/min (internal bypass)

Maximum operating pressure: 173 kPa

Cartridge dimensions: 248 x 118 mm

Replacement cartridge:

A30 ec 18,000 to 114,000 L

Important: The proper replacement cartridge model for your purifier is indicated on the label located on the front of your unit.

Cartridge life: 6 months from the date of installation

Run time: 6 hours minimum

Warranty: 2 years (housing)

REG. NOS. PCP ACT: Model NA: 24575 / Model PA: 25139

DOMESTIC

This purifier is for vinyl lined pools only.

Any other use voids manufacturer's warranty.

Nature² Compatibility

Do not use with the following:

- Copper-based algaecides
- Bromine or bromide chemicals
- Biguanides

We ask you to take the time to get familiar with this manual.

We believe the more you know, the more enjoyable and healthy your family's swimming experience will be – and the more you will reduce the time, effort and cost of maintaining your pool. Pool owners who switch from chemical programs to the Nature² purification technology spend less time maintaining their pools.

Every pool has its own characteristics of water type, amount of sunlight, etc. Discuss with your dealer the right "recipe" of water management to fit the particular circumstances of your pool and geographic climate.

Remember, your authorized Nature² dealer can provide professional advice and service.

Contents	Page
Installation	2
Balance the Water	3
Start Up	3
Follow the Recipe	3
Provide Filtration/Circulation	4
Troubleshooting	4
Replacing the Nature ² Purifier Cartridge	5
Winterizing Your Pool	5
Warranty	6



Mineral Purifiers for Pools

1 Installation

If you decide to install the Nature² Purifier yourself, follow the instructions on this page. The letters in parentheses refer to a diagram on page 5 titled Replacing the Nature² Purifier Cartridge.

Under normal pump and filter pressure conditions for vinyl liner pool systems, the flow rate to the inlet side of the purifier is 95-303 L/min which will allow proper flow through the cartridge.

Important: If your pump system is designed to produce flow rates greater than 303 L/min (80 GPM), ask your dealer about installing in a bypass configuration.

Installation

Equipment you will need:

- a set of **shut-off valves** or rubber winterizing line-plugs to use during installation or cartridge replacement to prevent draining (used in step 5 below)
- a filter **connector hose** of the same diameter as the other hoses on your pool equipment (used in step 7)

1 Decide where to install the Nature² Purifier. It should be installed:

- on a concrete slab to support the weight of the vessel,
- after the filter on the main return to the pool,
- before or after the heater,
- before any chemical dispenser or the discharge of an off-line chemical dispenser.

2 Wrap the Teflon tape around the threaded end of the hose adapters (supplied in the Parts Bag) as follows:

- Hold the adapter in one hand with the threaded end towards you.
- Wrap the tape clockwise until you have completed three or four wraps, overlapping about half of the Teflon tape already on the threads.

3 Hand-tighten both the hose adapters into the base of the Nature² Purifier. Then, with a wrench, tighten not more than one-half turn more. The purifier is now ready to be installed.

4 Run the pump with a clean filter and under normal operating conditions. It is important to start with a clean filter. Write down the pressure reading found on the pressure gauge attached to the filter. Fill in pressure for your pool here:

Under normal conditions, the pressure gauge reads ____ kPa.

5 Turn off the pump and totally isolate the equipment (to prevent draining the pool) by plugging all lines running from the pool to the equipment, closing in-line valves, and/or using the winterizing line plugs to seal off the skimmer pipe and all return inlets. You are now ready to insert the purifier into the pool's lines.

6 Disconnect the hose on the outlet side of the filter. Connect it instead to the outlet side of the purifier.

7 Install a new section of connector hose between the outlet side of the filter and the inlet side of the purifier. Use the hose clamps to secure the two ends of the new section of hose. The new installation should look like this:

Pool → Pump → Filter → Purifier → Pool.

8 Remove plugs or open all valves used to isolate the filter. Screw on the cap until it is snug. *Do not overtighten the cap.* Check that all connections are secure.

Important: *Do not install the Nature² Cartridge (C) yet.*

9 Turn on the pool's pump, check for leaks and repair any leaks you find.

10 Compare the pressure reading on the filter's gauge with the pressure written down in step 4.

If the pressure increased by:

between 6.9 and 13.8 kPa: All is well. Some increase is necessary for water to be forced into the purifier. You have completed the installation and are ready for the Start-Up instructions.

more than 13.8 kPa: There is too much pressure for the circulating pump, filter and purifier to work efficiently. The purifier may need to be connected via a partial bypass. Consult your dealer.

less than 6.9 kPa: See Flow Restrictor Installation on page 5.

Flow Restrictor Installation

When the purifier causes a filter pressure increase of less than 6.9 kPa, a flow restrictor will help ensure proper water flow through the purifier.

To install the flow restrictor:

1 Plug any lines (or close any valves) to prevent pool from losing water.

2 Disconnect hoses from purifier.

3 Remove cap and hose adapters.

4 Remove flow restrictor from Parts Bag.

5 While holding the purifier with the inlet port facing up, reach in and place restrictor (fingers facing down) into the flow control collar (hole approximately 25 mm in diameter).

Note: You may need to reach into the outlet port side of the unit to help position the restrictor.

6 Once the restrictor is positioned properly, place the unit on a flat, firm surface, keeping the inlet port face up.

7 Apply downward pressure on restrictor using a blunt-handled tool such as the end of a broom handle until it snaps into place.

8 Reinstall the purifier according to instructions on page 2. Recheck the system pressure.

2 Balance the Water

To find out if your pool water is balanced: • take a water sample to your dealer to be tested regularly, or • ask your dealer to recommend a pool test kit for water balance.

Element: pH Range: 7.2-7.8	If it's too low:	The surface of your pool can become etched. Metal parts in the pump and plumbing will corrode.	How to fix:	Add pH increaser.
	If it's too high:	"Scale" forms on the surface of your pool. The water can become cloudy. "Scale" forms on your pool equipment.	How to fix:	Add pH decreaser.
Element: Calcium Hardness Range: 200-300 ppm	If it's too low:	Water is less stable. In plaster pools, the calcium is taken out of the plaster, causing the surface to deteriorate.	How to fix:	Add calcium hardness increaser.
	If it's too high:	Rough, discolored deposits ("scale") will form on the pool surface and inside pool equipment.	How to fix:	Drain or dilute the pool water. Consult your dealer.
Element: Total Alkalinity Range: 80-120 ppm	If it's too low:	It provides no buffer so that you constantly get fluctuating pH readings, which can damage equipment and pool surfaces.	How to fix:	Use an alkalinity increaser.
	If it's too high:	White deposits ("scale") form on the tile line. The plaster on pool surface becomes rough or discolored. The water becomes cloudy or milky white.	How to fix:	Add acid to bring alkalinity down.

3 Start Up

Before starting up a new Nature² Cartridge, clean debris and algae out of the pool and equipment.

Important: *Do not install* the new cartridge until the pool water is chemically balanced.

1 Balance the pool water before installing the cartridge.

- pH 7.2-7.8
- Total hardness 200-300 ppm
- Total alkalinity 80-120 ppm

Consult your Nature² Dealer for specific water balance instructions.

2 Install the cartridge after water is balanced.

3 Shock the pool to burn off contaminants and to activate the cartridge. Follow label instructions of shock product being used.

4 Run the circulating pump either:

- 24 hours a day for 4 days, maintaining 1-3 ppm free available chlorine, or
- 6 hours a day for 14 days, maintaining 1-3 ppm free available chlorine.

5 Let free available chlorine residual drop but not below a minimum of 0.6 ppm once start-up period is completed.

4 Follow the Recipe

Low-Chlorine Recipe
(0.6 ppm free available chlorine minimum)

Once the 4-day or 14-day start-up period is done, allow the free available chlorine residual to drop but not below 0.6 ppm, then:

Ingredients:

- Nature² Purifier
- Chlorine granules, tablets, liquid or generator
- pH and total alkalinity adjusting chemicals
- Calcium hardness increaser, if needed
- Water test kit
- Cyanuric acid

When:

- Every day
- Once a week
- Twice a week
- As needed

What to do:

- Run pump and filter at least 6 hours every day.
- Balance pH and total alkalinity.
- Check chlorine residual, add chlorine to maintain a minimum of 0.6 ppm free available chlorine.
- If water is hazy, superchlorination. Follow product label instructions.
- After heavy use or rainstorm, superchlorination is recommended.
- Add cyanuric acid (stabilizer) to maintain 50 ppm.

5 Provide Filtration/Circulation

To manage: **You need to:**

Circulation Follow the manufacturer's directions for keeping the circulating pump in good working order and operate it at least six hours a day. Consult your Nature² dealer for optimum run times.

Filtration Check the pool's filter periodically and clean it as recommended by the manufacturer.

Troubleshooting Guide Consult your Nature² Dealer for additional assistance.

	Problem	What to look for	Treatment
Cloudy water Frequently caused by improper start up. See section on Start Up.	Poor filtration	Slow filter turnover rates	<ol style="list-style-type: none"> 1 Backwash and clean filter. 2 Run filter for 24 hours. 3 Increase run time per day.
	Algae growth	Hazy pool water; may have slightly green appearance.	Shock water (with dealer's guidance) and brush pool walls.
	Unbalanced water	<ol style="list-style-type: none"> 1. High hardness 2. High TDS (total dissolved solids) 3. High pH 4. High total alkalinity 	Balance the pool water
Algae Algae may be caused by insufficient levels of oxidizer and/or inadequate water circulation.	Green algae	Pea green color; attaches to pool walls; sometimes colors the entire body of water	<ol style="list-style-type: none"> 1 Check pH and adjust if necessary. 2 Shock water and brush pool walls. 3 Repeat steps 1 and 2 until algae is gone.
	Black algae	Black spots on pool walls	<ol style="list-style-type: none"> 1 Brush affected areas. 2 Shock water. 3 Add algaecide. 4 Vacuum pool. 5 Repeat steps 1 through 4 until algae is gone.
	Mustard algae	Yellow or brown film on steps or walls	<ol style="list-style-type: none"> 1 Brush affected areas. 2 Shock water. 3 Add algaecide. 4 Vacuum pool. 5 Repeat steps 1 through 4 until algae is gone.
Note: Regular algaecide treatments are recommended for outdoor pools that experience persistent algae problems. Do not use algae treatments containing either copper or sodium bromide.			
Stains	Blue/green	Copper or iron from pool equipment corrosion or water supply	<ol style="list-style-type: none"> 1 Adjust pH and total alkalinity to ideal ranges. 2 Vigorously brush stained areas. 3 Add sequestrant. 4 Run filter. 5 Twelve hours later, shock the pool. 6 Test and balance water. 7 Test pool water for dissolved metals.
	Red/brown	Iron or manganese from equipment corrosion or water supply.	<ol style="list-style-type: none"> 1 Adjust pH and total alkalinity to ideal ranges. 2 Vigorously brush stained areas. 3 Add sequestrant. 4 Run filter. 5 Twelve hours later, shock the pool. 6 Test and balance water. 7 Test pool water for dissolved metals.
	Black	Manganese in water supply.	<ol style="list-style-type: none"> 1 Adjust pH and total alkalinity to ideal ranges. 2 Vigorously brush stained areas. 3 Add sequestrant. 4 Run filter. 5 Twelve hours later, shock the pool. 6 Test and balance water. 7 Test pool water for dissolved metals.
	Metal tarnishing	High native mineral content in water; unbalanced water	Clean with soft cloth and mild detergent. Test water for minerals; use a sequestrant; maintain water balance.
Scale	Crusty deposits on pool surfaces	High pH and high total alkalinity	Adjust pH and total alkalinity to ideal ranges.
		High TDS (total dissolved solids) or high hardness levels	<ol style="list-style-type: none"> 1 Replace a volume of pool water with water low in calcium and dissolved solids. 2 Use sequestrant to prevent scale buildup if high hardness levels are a continuing problem.
Equipment	The purifier leaks	A. O-ring missing or improperly seated or	Lubricate O-ring with Teflon or silicone lubricant. Note: Do not use petroleum-based lubricants (will void warranty). Be sure O-ring is seated properly before securing housing cap.
		B. Faulty plumbing	Repair source of leak in plumbing.
	No flow to purifier	Dirty filter (one indication: pressure 55-69 kPa higher than normal)	Clean or backwash filter so operating pressure is always within 48 kPa of a new filter.

Replacing the Nature² Purifier Cartridge

Every cartridge comes with a label to indicate the date when the cartridge should be replaced. When you buy the cartridge, fix the label to indicate six months from the current date. A cartridge lasts six months under normal operating conditions.

To replace the cartridge:

- 1 **Shut off your pool's pump and filter.**
- 2 **Close any valves between the filter and pool** to prevent draining the pool.
- 3 **Unscrew the housing cap (A)** by twisting the cap counterclockwise until the cap is free of the housing base. If the cap is hard to twist, use a long-shafted screwdriver as a twist handle, placing it in the slot at the top of the housing cap.
- 4 **Lift out the old cartridge** and, if necessary, lubricate the O-ring (B).

Important: Use only a silicone-based, high-viscosity grease. Do not use a petroleum-based lubricant because it will damage the Nature² Purifier and invalidate your warranty.

- 5 **Insert the new cartridge.**
- 6 **Set the O-ring and cap in place** and screw the cap clockwise until it is snug. *Do not overtighten.*
- 7 **Open any valves that were closed** to isolate the Nature² Purifier in step 2.
- 8 **Restart your pool's pump.** Check for leaks and fix any leaking fittings.
- 9 **Follow the start up procedures** described on page 3.

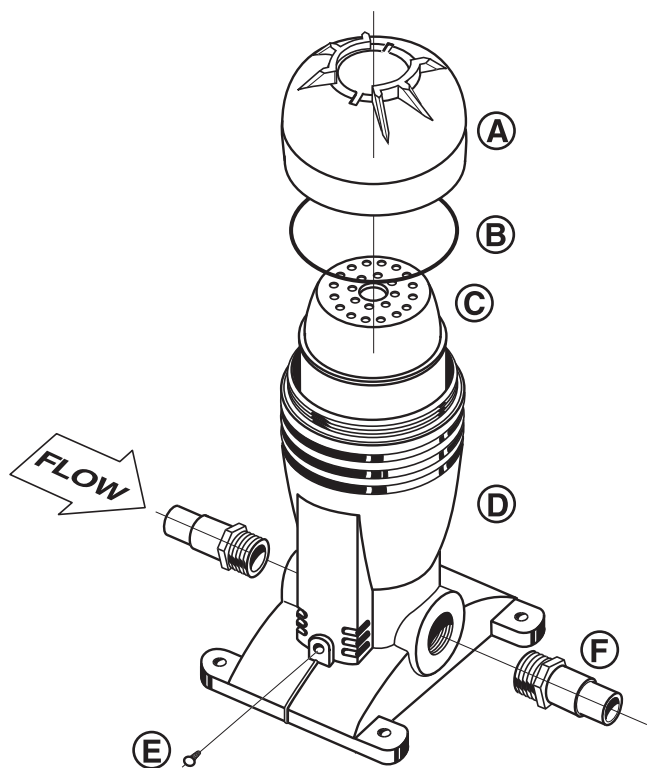

Winterizing Your Pool

Use these steps as a guide. Consult your dealer for specific information on your area.

Warm Climate

- 1 **Reduce the number of hours the pump runs** since the cooler weather decreases the spread of algae and other pollutants.
- 2 **There is no need to shock** the pool during cool weather unless the water becomes cloudy (as may occur after a winter storm). See Cloudy Water in Troubleshooting section.

Cold Climate

- 1 **Check total alkalinity and pH** of pool to make sure that they are in proper balance.
- 2 **Vacuum the pool bottom** to remove any debris or other potential contaminants.
- 3 **Shock** the pool to clear the water.
- 4 **Add a winter algaecide** following manufacturer's instructions.

Important: Do *not* use a winter algaecide with copper in it. This will void the Nature² no-stain warranty.

- 5 **Backwash the filter.**
- 6 **Drain part of the pool water.** The amount to drain varies from one part of the country to another. Consult your dealer for advice.
- 7 **Winterize the purifier** as follows:
 - Unscrew the housing cap (A) from the purifier base.
 - Remove the winter drain plug (E) and drain the water completely out of the base of the purifier.
 - Lift out the purifier cartridge and dispose of it.
 - Set the housing cap and cap O-ring (B) in place and screw it tight.
 - Store the purifier with your pool equipment, indoors if possible.
- 8 **Winterize the pipes** with pool antifreeze following manufacturer's instructions.
- 9 **Drain the water** out of all equipment (pump, filter, etc.).
- 10 **Store** all baskets, hoses and cleaning equipment, indoors if possible.
- 11 **Cover the pool** with a winter cover.

Reference

Letter	Part	Part No.
A	Housing Cap	26-0109
B	Cap O-ring	17-0061
C	Cartridge	See front page
D	Housing	26-0100
E	Winter Drain Plug	17-0021
F	Hose Adapter	17-0002

Warranty

Housing Warranty

The Nature² Purifier you have purchased was manufactured with care and is warranted to be free of defects in materials and workmanship for 2 years from the date it was installed. Your warranty registration card must be completed and mailed to Zodiac Pool Care, Inc. to establish your installation date. This warranty does not cover damage caused by abuse, misuse, accidents or any alterations to the purifier. Report claims to your authorized Nature² dealer. Zodiac Pool Care, Inc. reserves the right to replace any purifier instead of repairing it.

Six-Month Pro-Rated Cartridge Warranty

Nature² Purifier cartridges are warranted to be free of defects in materials and workmanship and to perform to your satisfaction for a period of six months from the date of installation. This warranty does not cover damage caused by accident, misuse or alteration or by the use of any biguanide products, copper-based algaecides or any products containing bromine or bromide-based chemicals. If the cartridge is defective or does not perform to your complete satisfaction for the entire six months, we will make prorated rebate based on your actual period of use. Please consult this Owners Manual for proper use.

Non-Staining Warranty

Your Nature² Purifier cartridge is warranted not to cause copper staining in your pool. This warranty requires only that you exercise reasonable care of your pool and keep water in balance at all times, and not use a copper-based algaecide. This Nature² Owners Manual will guide you as to how to maintain your pool properly when using the Nature² Purifier. This warranty does not cover discoloration to chromium fittings which may discolor slightly over time and are easily cleaned with a mild detergent.

There are no other warranties, expressed or implied. All incidental and consequential damages are excluded from the warranty except where state law is different. This warranty gives you specific legal rights. You may have other rights which vary from province to province. Proof of purchase is required to make any claims on the above warranties, so please keep your dated receipt.



This label transcript service is offered by the Pest Management Regulatory Agency to provide efficient searching for label information. This service and this information do not replace the official hard-copy label. The PMRA does not provide any guarantee or assurance that the information obtained through this service is accurate, current or correct, and is therefore not liable for any loss resulting, directly or indirectly, from reliance upon this service.